

ONVIF[™]

Access Control Device

Test Specification

Version 18.06

June, 2018

© 2018 ONVIF, Inc. All rights reserved.

Recipients of this document may copy, distribute, publish, or display this document so long as this copyright notice, license and disclaimer are retained with all copies of the document. No license is granted to modify this document.

THIS DOCUMENT IS PROVIDED "AS IS," AND THE CORPORATION AND ITS MEMBERS AND THEIR AFFILIATES, MAKE NO REPRESENTATIONS OR WARRANTIES, EXPRESS OR IMPLIED, INCLUDING BUT NOT LIMITED TO, WARRANTIES OF MERCHANTABILITY, FITNESS FOR A PARTICULAR PURPOSE, NON-INFRINGEMENT, OR TITLE; THAT THE CONTENTS OF THIS DOCUMENT ARE SUITABLE FOR ANY PURPOSE; OR THAT THE IMPLEMENTATION OF SUCH CONTENTS WILL NOT INFRINGE ANY PATENTS, COPYRIGHTS, TRADEMARKS OR OTHER RIGHTS.

IN NO EVENT WILL THE CORPORATION OR ITS MEMBERS OR THEIR AFFILIATES BE LIABLE FOR ANY DIRECT, INDIRECT, SPECIAL, INCIDENTAL, PUNITIVE OR CONSEQUENTIAL DAMAGES, ARISING OUT OF OR RELATING TO ANY USE OR DISTRIBUTION OF THIS DOCUMENT, WHETHER OR NOT (1) THE CORPORATION, MEMBERS OR THEIR AFFILIATES HAVE BEEN ADVISED OF THE POSSIBILITY OF SUCH DAMAGES, OR (2) SUCH DAMAGES WERE REASONABLY FORESEEABLE, AND ARISING OUT OF OR RELATING TO ANY USE OR DISTRIBUTION OF THIS DOCUMENT. THE FOREGOING DISCLAIMER AND LIMITATION ON LIABILITY DO NOT APPLY TO, INVALIDATE, OR LIMIT REPRESENTATIONS AND WARRANTIES MADE BY THE MEMBERS AND THEIR RESPECTIVE AFFILIATES TO THE CORPORATION AND OTHER MEMBERS IN CERTAIN WRITTEN POLICIES OF THE CORPORATION.

REVISION HISTORY

Vers.	Date	Description
13.06	Jun, 2013	First issue
13.12	Dec, 2013	Minor updates.
17.12	Aug 08, 2017	Current document name was changed from Access Control Test Specification to Access Control Device Test Specification. The document formatting was updated.
18.06	Jun 21, 2018	Reformatting document using new template

Table of Contents

1 Introduction 8

 1.1 Scope 8

 1.1.1 Capabilities 9

 1.1.2 Access Point 9

 1.1.3 Area 9

 1.1.4 External Authorization 9

 1.1.5 Property Events 10

 1.1.6 Access granted events 10

 1.1.7 Access taken events 10

 1.1.8 Access not taken events 10

 1.1.9 Access denied events 11

 1.1.10 Duress events 11

 1.1.11 Consistency 11

 1.1.12 Access Point Change Events 11

 1.1.13 Area Change Events 11

2 Terms and Definitions 12

 2.1 Definitions 12

 2.2 Abbreviations 12

3 Test Overview 13

 3.1 Test Setup 13

 3.1.1 Network Configuration for DUT 13

 3.2 Prerequisites 14

 3.3 Test Policy 16

 3.3.1 Capabilities 16

 3.3.2 Access Point 16

 3.3.3 Area 17

 3.3.4 External Authorization 18

 3.3.5 Property Events 19

 3.3.6 Access granted events 20

 3.3.7 Access taken events 20

- 3.3.8 Access not taken events 21
- 3.3.9 Access denied events 22
- 3.3.10 Duress events 23
- 3.3.11 Consistency 23
- 3.3.12 Access Point Change Events 24
- 3.3.13 Area Change Events 24
- 4 Access Control Test Cases 26**
- 4.1 Capabilities 26
 - 4.1.1 ACCESS CONTROL SERVICE CAPABILITIES 26
 - 4.1.2 GET SERVICES AND GET ACCESS CONTROL SERVICE
CAPABILITIES CONSISTENCY 26
- 4.2 Access Point 28
 - 4.2.1 GET ACCESS POINT INFO 28
 - 4.2.2 GET ACCESS POINT INFO WITH INVALID TOKEN 29
 - 4.2.3 GET ACCESS POINT INFO LIST – LIMIT 31
 - 4.2.4 GET ACCESS POINT INFO LIST – START REFERENCE AND LIMIT 32
 - 4.2.5 GET ACCESS POINT INFO LIST – NO LIMIT 35
 - 4.2.6 GET ACCESS POINT INFO – TOO MANY ITEMS 36
 - 4.2.7 GET ACCESS POINT STATE 38
 - 4.2.8 GET ACCESS POINT STATE WITH INVALID TOKEN 39
 - 4.2.9 ENABLE/DISABLE ACCESS POINT 39
 - 4.2.10 ENABLE/DISABLE ACCESS POINT - COMMAND NOT SUPPORTED 42
 - 4.2.11 ENABLE ACCESS POINT WITH INVALID TOKEN 44
 - 4.2.12 DISABLE ACCESS POINT WITH INVALID TOKEN 44
- 4.3 Area 45
 - 4.3.1 GET AREA INFO 45
 - 4.3.2 GET AREA INFO WITH INVALID TOKEN 47
 - 4.3.3 GET AREA INFO LIST – LIMIT 48
 - 4.3.4 GET AREA INFO LIST – START REFERENCE AND LIMIT 50
 - 4.3.5 GET AREA INFO – TOO MANY ITEMS 52
 - 4.3.6 GET AREA INFO LIST – NO LIMIT 53

- 4.4 External Authorization 55
 - 4.4.1 ACCESS CONTROL – ACCESS GRANTED TO ANONYMOUS (EXTERNAL AUTHORIZATION) 55
 - 4.4.2 ACCESS CONTROL – ACCESS DENIED TO ANONYMOUS (EXTERNAL AUTHORIZATION) 58
 - 4.4.3 ACCESS CONTROL – ACCESS TIMEOUT TO ANONYMOUS (EXTERNAL AUTHORIZATION) 62
 - 4.4.4 ACCESS CONTROL – ACCESS GRANTED WITH CREDENTIAL (EXTERNAL AUTHORIZATION) 65
 - 4.4.5 ACCESS CONTROL – ACCESS DENIED WITH CREDENTIAL (EXTERNAL AUTHORIZATION) 69
 - 4.4.6 ACCESS CONTROL – ACCESS TIMEOUT WITH CREDENTIAL (EXTERNAL AUTHORIZATION) 73
 - 4.4.7 EXTERNAL AUTHORIZATION WITH INVALID TOKEN 76
 - 4.4.8 EXTERNAL AUTHORIZATION – COMMAND NOT SUPPORTED 77
- 4.5 Property Events 78
 - 4.5.1 ACCESS CONTROL – ACCESS POINT ENABLED EVENT 78
 - 4.5.2 ACCESS CONTROL – ACCESS POINT ENABLED EVENT STATE CHANGE 81
- 4.6 Access granted events 84
 - 4.6.1 ACCESS CONTROL – ACCESS GRANTED TO ANONYMOUS EVENT 84
 - 4.6.2 ACCESS CONTROL – ACCESS GRANTED WITH CREDENTIAL EVENT 86
- 4.7 Access taken events 89
 - 4.7.1 ACCESS CONTROL – ACCESS TAKEN BY ANONYMOUS EVENT 89
 - 4.7.2 ACCESS CONTROL – ACCESS TAKEN WITH CREDENTIAL EVENT 92
- 4.8 Access not taken events 95
 - 4.8.1 ACCESS CONTROL – ACCESS NOT TAKEN BY ANONYMOUS EVENT ... 95
 - 4.8.2 ACCESS CONTROL – ACCESS NOT TAKEN WITH CREDENTIAL EVENT 98
- 4.9 Access denied events 102

4.9.1	ACCESS CONTROL – ACCESS DENIED TO ANONYMOUS EVENT	102
4.9.2	ACCESS CONTROL – ACCESS DENIED WITH CREDENTIAL EVENT	104
4.9.3	ACCESS CONTROL – ACCESS DENIED WITH CREDENTIAL EVENT (CREDENTIAL NOT FOUND – CARD)	107
4.10	Duress events	110
4.10.1	ACCESS CONTROL – DURESS	110
4.11	Consistency	113
4.11.1	GET AREA INFO LIST AND GET ACCESS POINT INFO LIST CONSISTENCY	113
4.12	Access Point Configuration	114
4.12.1	ACCESS CONTROL – ADD OR CHANGE ACCESS POINT EVENT	114
4.12.2	ACCESS CONTROL – REMOVE ACCESS POINT EVENT	116
4.13	Area Configuration	118
4.13.1	ACCESS CONTROL – ADD OR CHANGE AREA EVENT	118
4.13.2	ACCESS CONTROL – REMOVE AREA EVENT	121
A	Helper Procedures and Additional Notes	124
A.1	Get Complete Access Point Info List	124
A.2	Get Complete Area Info List	124

1 Introduction

The goal of the ONVIF test specification set is to make it possible to realize fully interoperable IP physical security implementation from different vendors. The set of ONVIF test specification describes the test cases needed to verify the [ONVIF Network Interface Specs] and [ONVIF Conformance] requirements. And also the test cases are to be basic inputs for some Profile specification requirements. It also describes the test framework, test setup, pre-requisites, test policies needed for the execution of the described test cases.

This ONVIF Access Control Test Specification acts as a supplementary document to the [ONVIF Network Interface Specs], illustrating necessary test cases to be executed and passed. And also this specification acts as an input document to the development of test tool which will be used to test the ONVIF device implementation conformance towards ONVIF standard. This test tool is referred as ONVIF Client hereafter.

1.1 Scope

This ONVIF Access Control Test Specification defines and regulates the conformance testing procedure for the ONVIF conformant devices. Conformance testing is meant to be functional black-box testing. The objective of this specification is to provide test cases for testing individual requirements of ONVIF devices according to ONVIF Access Control service which is defined in [ONVIF Network Interface Specs].

The principal intended purposes are:

1. Provide self-assessment tool for implementations.
2. Provide comprehensive test suite coverage for [ONVIF Network Interface Specs].

This specification does not address the following:

1. Product use cases and non-functional (performance and regression) testing.
2. SOAP Implementation Interoperability test i.e. Web Service Interoperability Basic Profile version 2.0 (WS-I BP 2.0).
3. Network protocol implementation Conformance test for HTTP, HTTPS, RTP protocol.
4. Wi-Fi Conformance test

The set of ONVIF Test Specification will not cover the complete set of requirements as defined in [ONVIF Network Interface Specs]; instead it would cover its subset.

This ONVIF Access Control Test Specification covers ONVIF Access Control service and Access Control Events which are a functional block of [ONVIF Network Interface Specs]. The following sections give a brief overview and scope of each functional block.

1.1.1 Capabilities

Capabilities test cases cover verification of getting Access Control Service capabilities. It means that the following commands are covered by these test cases:

- GetServices (Device Management Service)
- GetServiceCapabilities

1.1.2 Access Point

Access Point test cases cover verification of getting Access Point list, information, state and to enable/disable access point. It means that the following commands are covered by these test cases:

- GetAccessPointInfo
- GetAccessPointInfoList
- GetAccessPointState
- EnableAccessPoint
- DisableAccessPoint

1.1.3 Area

Area test cases cover verification of getting Area list and information. It means that the following commands are covered by these test cases:

- GetAreaInfo
- GetAreaInfoList

1.1.4 External Authorization

External Authorization test cases cover verification of external authorization procedure. It means that the following commands and events are covered by these test cases:

- ExternalAuthorization
- tns1:AccessControl/AccessGranted/Anonymous
- tns1:AccessControl/AccessGranted/Credential
- tns1:AccessControl/Denied/Anonymous

- tns1:AccessControl/Denied/Credential
- tns1:AccessControl/Request/Anonymous
- tns1:AccessControl/Request/Timeout
- tns1:AccessControl/Request/Credential

1.1.5 Property Events

Property events test cases cover verification of property events provided by Access Control Service. It means that the following commands and events are covered by these test cases:

- EnableAccessPoint
- DisableAccessPoint
- tns1:AccessPoint/State/Enabled

1.1.6 Access granted events

Access Granted events test cases cover verification of access granted events provided by Access Control Service. It means that the following events are covered by these test cases:

- tns1:AccessControl/AccessGranted/Anonymous
- tns1:AccessControl/AccessGranted/Credential

1.1.7 Access taken events

Access taken events test cases cover verification of access taken events provided by Access Control Service. It means that the following events are covered by these test cases:

- tns1:AccessControl/AccessTaken/Anonymous
- tns1:AccessControl/AccessTaken/Credential

1.1.8 Access not taken events

Access not taken events test cases cover verification of access not taken events provided by Access Control Service. It means that the following events are covered by these test cases:

- tns1:AccessControl/AccessNotTaken/Anonymous
- tns1:AccessControl/AccessNotTaken/Credential

1.1.9 Access denied events

Access denied events test cases cover verification of access denied events provided by Access Control Service. It means that the following events are covered by these test cases:

- tns1:AccessControl/Denied/Anonymous
- tns1:AccessControl/Denied/Credential
- tns1:AccessControl/Denied/CredentialNotFound/Card

1.1.10 Duress events

Duress events test cases cover verification of duress events provided by Access Control Service. It means that the following events are covered by the following test case:

- tns:AccessControl/Duress

1.1.11 Consistency

Consistency test cases cover verification of consistency between different entities and commands. It means that consistency between the following entities is covered by the following test case:

- Access Point Info and Get Area Info

1.1.12 Access Point Change Events

Access point change events test cases cover verification of access point change events provided by Access Control Service. It means that the following events are covered by these test cases:

- tns1:Configuration/AccessPoint/Change
- tns1:Configuration/AccessPoint/Removed

1.1.13 Area Change Events

Area change events test cases cover verification of area change events provided by Access Control Service. It means that the following events are covered by these test cases:

- tns1:Configuration/Area/Change
- tns1:Configuration/Area/Removed

2 Terms and Definitions

2.1 Definitions

This section defines terms that are specific to the ONVIF Device IO Service and tests. For a list of applicable general terms and definitions, please see [ONVIF Base Test].

Access Point	A logical composition of a physical door and ID point(s) controlling access in one direction.
Access Point Disable	If an Access Point is disabled, it will not be considered in the decision making process and no commands will be issued from that Access Point to the Door configured for that Access Point. When an Access Point is disabled, the associated ID Point may or may not be disabled or shut down. Clients may still be able to command the Door Controller to control associated door even though that door is also referenced by a disabled access point.
Credential	A physical/tangible object, a piece of knowledge, or a facet of a person's physical being, that enables an individual access to a given physical facility or computer-based information system.
Credential Number	A sequence of bytes uniquely identifying a credential at an access point.
Door	A physical door, barrier, turnstile, etc which can be controlled remotely and restricts access between two areas. A door is usually equipped with an electronic lock and a door monitor.
Duress	Forcing a person to provide access to a secure area against that person's wishes.
ID Point	A device that converts reader signals to protocols recognized by an authorization engine. It can be card reader, REX, biometric reader etc.

2.2 Abbreviations

This section describes abbreviations used in this document.

HTTP Hypertext Transfer (or Transport) Protocol

PACS Physical Access Control System

3 Test Overview

This section provides information the test setup procedure and required prerequisites, and the test policies that should be followed for test case execution.

3.1 Test Setup

3.1.1 Network Configuration for DUT

The generic test configuration for the execution of test cases defined in this document is as shown below (Figure 4.1).

Based on the individual test case requirements, some of the entities in the below setup may not be needed for the execution of those corresponding test cases.

Figure 3.1. Test Configuration for DUT

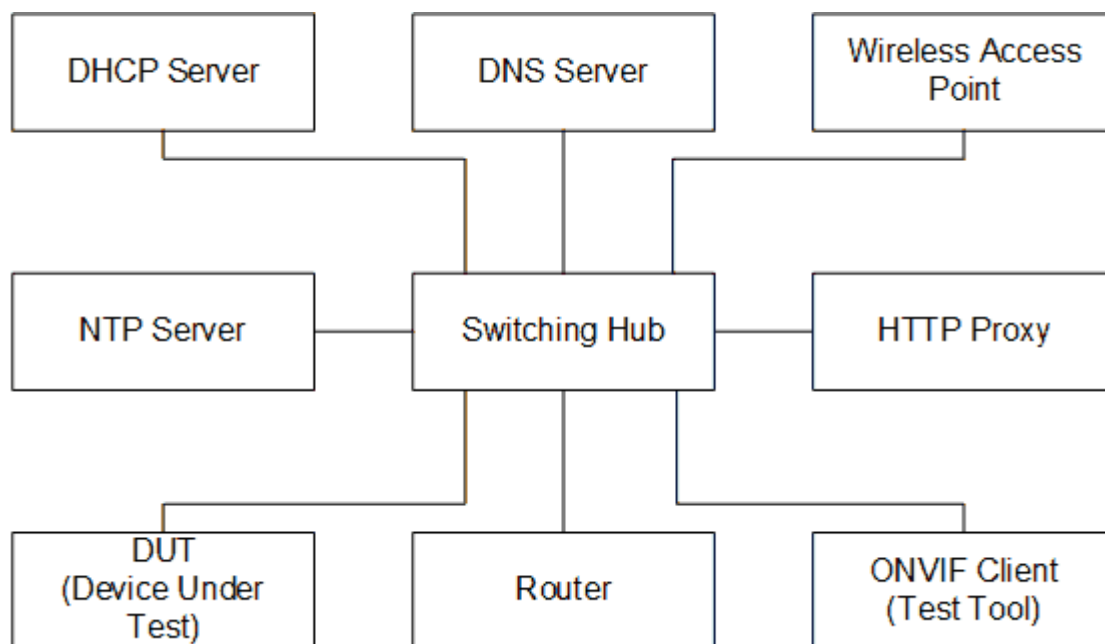

DUT: ONVIF device to be tested. Hereafter, this is referred to as DUT (Device Under Test).

ONVIF Client (Test Tool): Tests are executed by this system and it controls the behavior of the DUT. It handles both expected and unexpected behavior.

HTTP Proxy: provides facilitation in case of RTP and RTSP tunneling over HTTP.

Wireless Access Point: provides wireless connectivity to the devices that support wireless connection.

DNS Server: provides DNS related information to the connected devices.

DHCP Server: provides IPv4 Address to the connected devices.

NTP Server: provides time synchronization between ONVIF Client and DUT.

Switching Hub: provides network connectivity among all the test equipments in the test environment. All devices should be connected to the Switching Hub.

Router: provides router advertisements for IPv6 configuration.

3.2 Prerequisites

The pre-requisites for executing the test cases described in this Test Specification are the following:

- The DUT shall be configured with an IPv4 address.
- The DUT shall be IP reachable [in the test configuration].
- The DUT shall be able to be discovered by the ONVIF Device Test Tool.
- The DUT shall be configured with the time i.e. manual configuration of UTC time and if NTP is supported by DUT, then NTP time shall be synchronized with NTP Server.
- The DUT time and ONVIF Device Test tool time shall be synchronized with each other either manually or by common NTP server.
- Test Operator shall configure Operation Delay properly so that it would have enough time to receive Notification messages for the following test cases for ONVIF Device Test Tool (see test description for more details):
 - [4.4.1 ACCESS CONTROL – ACCESS GRANTED TO ANONYMOUS \(EXTERNAL AUTHORIZATION\)](#)
 - [4.4.2 ACCESS CONTROL – ACCESS DENIED TO ANONYMOUS \(EXTERNAL AUTHORIZATION\)](#)
 - [4.4.3 ACCESS CONTROL – ACCESS TIMEOUT TO ANONYMOUS \(EXTERNAL AUTHORIZATION\)](#)
 - [4.4.4 ACCESS CONTROL – ACCESS GRANTED WITH CREDENTIAL \(EXTERNAL AUTHORIZATION\)](#)
 - [4.4.5 ACCESS CONTROL – ACCESS DENIED WITH CREDENTIAL \(EXTERNAL AUTHORIZATION\)](#)

- 4.4.6 ACCESS CONTROL – ACCESS TIMEOUT WITH CREDENTIAL (EXTERNAL AUTHORIZATION)
- 4.5.1 ACCESS CONTROL – ACCESS POINT ENABLED EVENT
- 4.5.2 ACCESS CONTROL – ACCESS POINT ENABLED EVENT STATE CHANGE
- 4.6.1 ACCESS CONTROL – ACCESS GRANTED TO ANONYMOUS EVENT
- 4.6.2 ACCESS CONTROL – ACCESS GRANTED WITH CREDENTIAL EVENT
- 4.7.1 ACCESS CONTROL – ACCESS TAKEN BY ANONYMOUS EVENT
- 4.7.2 ACCESS CONTROL – ACCESS TAKEN WITH CREDENTIAL EVENT
- 4.8.1 ACCESS CONTROL – ACCESS NOT TAKEN BY ANONYMOUS EVENT
- 4.8.2 ACCESS CONTROL – ACCESS NOT TAKEN WITH CREDENTIAL EVENT
- 4.9.1 ACCESS CONTROL – ACCESS DENIED TO ANONYMOUS EVENT
- 4.9.2 ACCESS CONTROL – ACCESS DENIED WITH CREDENTIAL EVENT
- 4.9.3 ACCESS CONTROL – ACCESS DENIED WITH CREDENTIAL EVENT (CREDENTIAL NOT FOUND – CARD)
- 4.10.1 ACCESS CONTROL – DURESS
- 4.12.1 ACCESS CONTROL – ADD OR CHANGE ACCESS POINT EVENT
- 4.12.2 ACCESS CONTROL – REMOVE ACCESS POINT EVENT
- 4.13.1 ACCESS CONTROL – ADD OR CHANGE AREA EVENT
- 4.13.2 ACCESS CONTROL – REMOVE AREA EVENT
- At least one Access Point is configured and added to the DUT.
- At least one Access Point with Enable/Disable capability is configured and added to the DUT, if Enable/Disable capability is supported by the DUT.
- At least one Access Point with Duress capability is configured and added to the DUT, if Duress capability is supported by the DUT.
- At least one Access Point with Access Taken capability is configured and added to the DUT, if Access Taken capability is supported by the DUT.

- At least one Access Point with External Authorization capability is configured and added to the DUT, if External Authorization capability is supported by the DUT.
- At least one Access Point with Anonymous Access capability is configured and added to the DUT, if Anonymous Access capability is supported by the DUT.
- At least one Access Point with Anonymous Access capability and External Authorization capability is configured and added to the DUT, if Anonymous Access capability and External Authorization capability are supported by the DUT.
- At least one Access Point with Anonymous Access capability and Access Taken capability is configured and added to the DUT, if Anonymous Access capability and Access Taken capability are supported by the DUT.
- At least one Access Point with `tns1:AccessControl/Denied/CredentialNotFound/Card` event capability is configured and added to the DUT, if `tns1:AccessControl/Denied/CredentialNotFound/Card` capability is supported by the DUT.
- At least one Area is configured and added to the DUT, if it is possible for the DUT.

3.3 Test Policy

This section describes the test policies specific to the test case execution of each functional block.

The DUT shall adhere to the test policies defined in this section.

3.3.1 Capabilities

DUT shall give the Access Control Service entry point by `GetServices` command, if DUT supports this service. Otherwise, these test cases will be skipped.

DUT shall support `GetServices` and `GetServiceCapabilities` command.

Please, refer to [Section 4.1](#) for Capabilities Test Cases.

3.3.2 Access Point

DUT shall give the Access Control Service entry point by `GetServices` command, if DUT supports this service. Otherwise, these test cases will be skipped.

DUT shall support `GetServices` and `GetServiceCapabilities` command.

DUT shall support at least one Access Point. And also at least one Access Point shall be added and configured on device.

DUT shall support the following commands:

- `GetAccessPointInfo`
- `GetAccessPointInfoList`
- `GetAccessPointState`

DUT shall return capabilities for each specific access point. If DUT returns Disable Access Point capability as supported by access point, then DUT shall support the following commands for this access point:

- `DisableAccessPoint`
- `EnableAccessPoint`

DUT shall not return any fault, if `GetAccessPointInfo` was invoked for nonexistent Access Point token. Such tokens shall be ignored.

DUT shall not return more items in `GetAccessPointInfo` and `GetAccessPointInfoList` responses than specified in service capabilities by `MaxLimit`.

DUT shall not return more items in `GetAccessPointInfoList` response than specified by `Limit` parameter in request.

DUT shall return SOAP 1.2 fault message (`InvalidArgs/TooManyItems`), if more items than `MaxLimit` were requested by `GetAccessPointInfo` command.

DUT should return SOAP 1.2 fault message (`InvalidArgVal/NotFound`), if `GetAccessPointState`, `EnableAccessPoint` or `DisableAccessPoint` command was invoked for nonexistent Access Point token.

DUT should return SOAP 1.2 fault message (`ActionNotSupported/NotSupported`), if `EnableAccessPoint` or `DisableAccessPoint` command was invoked for Access Point without Disable Access Point capability token.

Please, refer to [Section 4.2](#) for Access Point Test Cases.

3.3.3 Area

DUT shall give the Access Control Service entry point by `GetServices` command, if DUT supports this service. Otherwise, these test cases will be skipped.

DUT shall support `GetServiceCapabilities` command.

If DUT supports at least one Area, one Area shall be added and configured on device.

DUT shall support the following commands:

- GetAreaInfo
- GetAreaInfoList

DUT shall not return any fault, if GetAreaInfo was invoked for nonexistent Area token. Such tokens shall be ignored.

DUT shall not return more items in GetAreaInfo and GetAreaInfoList responses than specified in service capabilities by MaxLimit.

DUT shall not return more items in GetAreaInfoList response than specified by Limit parameter in request.

DUT shall return SOAP 1.2 fault message (InvalidArgs/TooManyItems), if more items than MaxLimit were requested by GetAreaInfo command.

Please, refer to [Section 4.3](#) for Area Test Cases.

3.3.4 External Authorization

DUT shall give the Access Control Service entry point and Event Service entry point by GetServices command, if DUT supports Access Control service. Otherwise, these test cases will be skipped.

DUT shall support GetServiceCapabilities command.

DUT shall return capabilities for each specific access point.

If DUT returns External Authorization capability as supported by access point, then DUT shall support the following commands and events for this access point:

- ExternalAuthorization
- tns1:AccessControl/AccessGranted/Credential
- tns1:AccessControl/Denied/Credential
- tns1:AccessControl/Request/Timeout
- tns1:AccessControl/Request/Credential

If DUT returns External Authorization capability and Anonymous Access capability as supported by access point, then DUT shall support the following events for this access point:

- tns1:AccessControl/AccessGranted/Anonymous
- tns1:AccessControl/Denied/Anonymous

- tns1:AccessControl/Request/Anonymous

DUT shall support GetEventProperties command and return all supported events in TopicSet.

DUT shall support Pull Point Subscription and Topic Expression filter.

DUT should return SOAP 1.2 fault message (InvalidArgVal/NotFound), if ExternalAuthorization command was invoked for nonexistent Access Point token.

DUT should return SOAP 1.2 fault message (ActionNotSupported/NotSupported), if ExternalAuthorization command was invoked for Access Point without External Authorization capability token.

A test operator shall manually invoke the following events if required:

- tns1:AccessControl/Request/Timeout
- tns1:AccessControl/Request/Credential
- tns1:AccessControl/Request/Anonymous

Please, refer to [Section 4.4](#) for External Authorization Test Cases.

3.3.5 Property Events

DUT shall give the Access Control Service entry point and Event Service entry point by GetServices command, if DUT supports Access Control service. Otherwise these test cases will be skipped.

DUT shall support GetServiceCapabilities command.

DUT shall support following property events:

- tns1:AccessPoint/State/Enabled

DUT shall return capabilities for each specific access point. If DUT returns Disable Access Point capability as supported by access point, then DUT shall support the following commands for this access point:

- DisableAccessPoint
- EnableAccessPoint

DUT shall support GetEventProperties command and return all supported events in TopicSet.

DUT shall support Pull Point Subscription and Topic Expression filter.

DUT shall generate property events with initial state after subscription was done.

DUT shall generate property events with current state after corresponding properties were changed.

Please, refer to [Section 4.5](#) for Property Events Test Cases.

3.3.6 Access granted events

DUT shall give the Access Control Service entry point and Event Service entry point by GetServices command, if DUT supports Access Control service. Otherwise these test cases will be skipped.

DUT shall support GetServiceCapabilities command.

DUT shall return capabilities for each specific access point.

DUT shall support the following events for each access point:

- tns1:AccessControl/AccessGranted/Credential

If DUT returns Anonymous Access capability as supported by access point, then DUT shall support the following events for this access point:

- tns1:AccessControl/AccessGranted/Anonymous

DUT shall support GetEventProperties command and return all supported events in TopicSet.

DUT shall support Pull Point Subscription and Topic Expression filter.

A test operator shall manually invoke the following events if required:

- tns1:AccessControl/AccessGranted/Anonymous
- tns1:AccessControl/AccessGranted/Credential

Please, refer to [Section 4.6](#) for Access granted events Test Cases.

3.3.7 Access taken events

DUT shall give the Access Control Service entry point and Event Service entry point by GetServices command, if DUT supports Access Control service. Otherwise, these test cases will be skipped.

DUT shall support GetServiceCapabilities command.

DUT shall return capabilities for each specific access point.

DUT shall support the following events for each access point:

- tns1:AccessControl/AccessGranted/Credential

If DUT returns Anonymous Access capability as supported by access point, then DUT shall support the following events for this access point:

- tns1:AccessControl/AccessGranted/Anonymous

If DUT returns Access Taken capability as supported by access point, then DUT shall support the following events for this access point:

- tns1:AccessControl/AccessTaken/Credential

If DUT returns Anonymous Access capability and Access Taken capability as supported by access point, then DUT shall support the following events for this access point:

- tns1:AccessControl/AccessTaken/Anonymous

DUT shall support GetEventProperties command and return all supported events in TopicSet.

DUT shall support Pull Point Subscription and Topic Expression filter.

A test operator shall manually invoke the following events if required:

- tns1:AccessControl/AccessGranted/Anonymous
- tns1:AccessControl/AccessGranted/Credential
- tns1:AccessControl/AccessTaken/Anonymous
- tns1:AccessControl/AccessTaken/Credential

Please, refer to [Section 4.7](#) for Access taken events Test Cases.

3.3.8 Access not taken events

DUT shall give the Access Control Service entry point and Event Service entry point by GetServices command, if DUT supports Access Control service. Otherwise, these test cases will be skipped.

DUT shall support GetServiceCapabilities command.

DUT shall return capabilities for each specific access point.

DUT shall support the following events for each access point:

- tns1:AccessControl/AccessGranted/Credential

If DUT returns Anonymous Access capability as supported by access point, then DUT shall support the following events for this access point:

- tns1:AccessControl/AccessGranted/Anonymous

If DUT returns Access Taken capability as supported by access point, then DUT shall support the following events for this access point:

- tns1:AccessControl/AccessNotTaken/Credential

If DUT returns Anonymous Access capability and Access Taken capability as supported by access point, then DUT shall support the following events for this access point:

- tns1:AccessControl/AccessNotTaken/Anonymous

DUT shall support GetEventProperties command and return all supported events in TopicSet.

DUT shall support Pull Point Subscription and Topic Expression filter.

A test operator shall manually invoke the following events if required:

- tns1:AccessControl/AccessGranted/Anonymous
- tns1:AccessControl/AccessGranted/Credential
- tns1:AccessControl/AccessNotTaken/Anonymous
- tns1:AccessControl/AccessNotTaken/Credential

Please, refer to [Section 4.8](#) for Access not taken events Test Cases.

3.3.9 Access denied events

DUT shall give the Access Control Service entry point and Event Service entry point by GetServices command, if DUT supports Access Control service. Otherwise, these test cases will be skipped.

DUT shall support GetServiceCapabilities command.

DUT shall return capabilities for each specific access point.

DUT shall support the following events for each access point:

- tns1:AccessControl/Denied/Credential

If DUT returns tns1:AccessControl/Denied/CredentialNotFound/Card as supported, DUT shall support the following event for at least one configured access point:

- tns1:AccessControl/Denied/CredentialNotFound/Card

If DUT returns Anonymous Access capability as supported by access point, then DUT shall support the following events for this access point:

- tns1:AccessControl/Denied/Anonymous

DUT shall support GetEventProperties command and return all supported events in TopicSet.

DUT shall support Pull Point Subscription and Topic Expression filter.

A test operator shall manually invoke the following events if required:

- tns:AccessControl/Denied/Anonymous
- tns:AccessControl/Denied/Credential
- tns:AccessControl/Denied/CredentialNotFound/Card

Please, refer to [Section 4.9](#) for Access denied events Test Cases.

3.3.10 Duress events

DUT shall give the Access Control Service entry point and Event Service entry point by GetServices command, if DUT supports Access Control service. Otherwise, these test cases will be skipped.

DUT shall support GetServiceCapabilities command.

DUT shall return capabilities for each specific access point.

If DUT returns Duress capability as supported by access point, then DUT shall support the following events for this access point:

- tns:AccessControl/Duress

DUT shall support GetEventProperties command and return all supported events in TopicSet.

DUT shall support Pull Point Subscription and Topic Expression filter.

A test operator shall manually invoke the following events if required:

- tns:AccessControl/Duress

Please, refer to [Section 4.10](#) for Duress events Test Cases.

3.3.11 Consistency

DUT shall give the Access Control Service entry point by GetServices command, if DUT supports this service. Otherwise, these test cases will be skipped.

DUT shall support at least one Access Point. And also at least one Access Point shall be added and configured on device.

If DUT supports at least one Area, at least one Area shall be added and configured on device.

DUT shall support the following commands:

- GetAccessPointInfoList
- GetAreaInfoList

DUT shall not return other Area tokens, than listed in GetAreaInfoList responses, in AreaTo and AreaFrom fields of GetAccessPointInfo's.

Please, refer to [Section 4.11](#) for Consistency Test Cases.

3.3.12 Access Point Change Events

DUT shall give the Access Control Service entry point and Event Service entry point by GetServices command, if DUT supports Access Control service. Otherwise, these test cases will be skipped.

DUT shall support GetEventProperties command and return all supported events in TopicSet.

DUT shall support Pull Point Subscription and Topic Expression filter.

If DUT supports adding or changing access points, then DUT shall support the following events:

- tns1:Configuration/AccessPoint/Change

If DUT returns tns1:Configuration/AccessPoint/Change topic in GetEventProperties command, then DUT should have possibility to invoke it.

If DUT supports removing access points, then DUT shall support the following events:

- tns1:Configuration/AccessPoint/Removed

If DUT returns tns1:Configuration/AccessPoint/Removed topic in GetEventProperties command, then DUT should have possibility to invoke it.

A test operator shall manually invoke the following events if required:

- tns1:Configuration/AccessPoint/Change
- tns1:Configuration/AccessPoint/Removed

Please, refer to [Section 4.12](#) for Access Point Change events Test Cases.

3.3.13 Area Change Events

DUT shall give the Access Control Service entry point and Event Service entry point by GetServices command, if DUT supports Access Control service. Otherwise, these test cases will be skipped.

DUT shall support GetEventProperties command and return all supported events in TopicSet.

DUT shall support Pull Point Subscription and Topic Expression filter.

If DUT supports adding or changing areas, then DUT shall support the following events:

- tns1:Configuration/Area/Change

If DUT returns tns1:Configuration/Area/Change topic in GetEventProperties command, then DUT should have possibility to invoke it.

If DUT supports removing areas, then DUT shall support the following events:

- tns1:Configuration/Area/Removed

If DUT returns tns1:Configuration/Area/Removed topic in GetEventProperties command, then DUT should have possibility to invoke it.

A test operator shall manually invoke the following events if required:

- tns1:Configuration/Area/Change
- tns1:Configuration/Area/Removed

Please, refer to [Section 4.13](#) for Area Change events Test Cases.

4 Access Control Test Cases

4.1 Capabilities

4.1.1 ACCESS CONTROL SERVICE CAPABILITIES

Test Case ID: ACCESSCONTROL-1-1-1

Specification Coverage: Capability exchange (ONVIF Core Specification), `GetServiceCapabilities` (ONVIF Access Control Service Specification)

Feature Under Test: `GetServiceCapabilities` (for Access Control Service)

WSDL Reference: `accesscontrol.wsdl`

Test Purpose: To verify DUT Access Control Service Capabilities.

Pre-Requisite: Access Control Service was received from the DUT.

Test Configuration: ONVIF Client and DUT

Test Procedure:

1. Start an ONVIF Client.
2. Start the DUT.
3. ONVIF Client will invoke **`GetServiceCapabilities`** request to retrieve DUT access control service capabilities.
4. Verify the **`GetServiceCapabilitiesResponse`** message from the DUT.

Test Result:

PASS –

- DUT passes all assertions.

FAIL –

- DUT did not send **`GetServiceCapabilitiesResponse`** message.

4.1.2 GET SERVICES AND GET ACCESS CONTROL SERVICE CAPABILITIES CONSISTENCY

Test Case ID: ACCESSCONTROL-1-1-2

Specification Coverage: Capability exchange (ONVIF Core Specification), GetServiceCapabilities (ONVIF Access Control Service Specification)

Feature Under Test: GetServices, GetServiceCapabilities (for Access Control Service)

WSDL Reference: devicemgmt.wsdl, accesscontrol.wsdl

Test Purpose: To verify Get Services and Access Control Service Capabilities consistency.

Pre-Requirement: Access Control Service was received from the DUT.

Test Configuration: ONVIF Client and DUT

Test Procedure:

1. Start an ONVIF Client.
2. Start the DUT.
3. ONVIF Client will invoke **GetServices** request (IncludeCapability = true) to retrieve all services of the DUT with service capabilities.
4. Verify the **GetServicesResponse** message from the DUT.
5. ONVIF Client will invoke **GetServiceCapabilities** request to retrieve DUT Access Control service capabilities.
6. Verify the **GetServiceCapabilitiesResponse** message from the DUT.

Test Result:

PASS –

- DUT passes all assertions.

FAIL –

- The DUT did not send valid **GetServicesResponse** message.
- The DUT did not send valid **GetServiceCapabilitiesResponse** message.
- The DUT sent different Capabilities in **GetServicesResponse** message and in **GetServiceCapabilitiesResponse** message.

Note: Service will be defined as Access Controller service if it has Namespace element that is equal to “http://www.onvif.org/ver10/accesscontrol/wsdl”.

Note: Capabilities in **GetServicesResponse** message and in **GetServiceCapabilitiesResponse** message will be assumed as different in the following cases:

- Values of MaxLimit attribute are different.

4.2 Access Point

4.2.1 GET ACCESS POINT INFO

Test Case ID: ACCESSCONTROL-2-1-1

Specification Coverage: GetAccessPointInfo (ONVIF Access Control Service Specification)

Feature Under Test: GetAccessPointInfo

WSDL Reference: accesscontrol.wsdl

Test Purpose: To verify Get Access Point Info.

Pre-Requisite: Access Control Service was received from the DUT. At least one Access Point is configured and added to the DUT.

Test Configuration: ONVIF Client and DUT

Test Procedure:

1. Start an ONVIF Client.
2. Start the DUT.
3. Get complete list of access points from the DUT (see [Annex A.1](#)).
4. ONVIF Client will invoke **GetServiceCapabilities** request to retrieve MaxLimit capability.
5. Verify the **GetServiceCapabilitiesResponse** message from the DUT.
6. ONVIF Client will invoke **GetAccessPointInfo** request (Token list with subset of AccessPointInfo.token values from a complete list of access points at step 3 with token number equal to MaxLimit) to retrieve a subset of Access Point Information from the DUT.
7. Verify the **GetAccessPointInfoResponse** message from the DUT.
8. Verify that all requested AccessPointInfo items are in **GetAccessPointInfoResponse** message.
9. ONVIF Client will invoke **GetAccessPoint** request (Token = Token1, where Token1 is the first token from the complete list of access points at step 3) to retrieve AccessPoint Information for specified token from the DUT.

10. Verify the **GetAccessPointInfoResponse** message from the DUT.
11. Verify that **GetAccessPointInfoResponse** message contains AccessPointInfo only for specified token.
12. Repeat steps 9-11 for all other tokens from a complete list of access points at step 3.

Test Result:**PASS –**

- DUT passes all assertions.

FAIL –

- The DUT did not send valid **GetAccessPointInfoResponse** message.
- The DUT returned **GetAccessPointInfoResponse** message that contains at least two AccessPointInfo items with equal tokens.
- The DUT did not return requested AccessPointInfo items in **GetAccessPointInfoResponse** message for step 7 or 10.
- The DUT returned more items than requested in **GetAccessPointInfoResponse** message for step 7 or 10.
- The DUT did not return at least one Access Point at step 3.
- The DUT did not send valid **GetServiceCapabilitiesResponse**.

Note: If the DUT did not return any AccessPointInfo on complete list of access points at step 3, skip steps 4-12, fail test and go to the next test.

Note: In case MaxLimit is equal to 0, 1 will be used instead in requests.

4.2.2 GET ACCESS POINT INFO WITH INVALID TOKEN

Test Case ID: ACCESSCONTROL-2-1-2

Specification Coverage: GetAccessPointInfo (ONVIF Access Control Service Specification)

Feature Under Test: GetAccessPointInfo

WSDL Reference: accesscontrol.wsdl

Test Purpose: To verify Get Access Point Info with invalid Token.

Pre-Requisite: Access Control Service was received from the DUT. At least one Access Point is configured and added to the DUT.

Test Configuration: ONVIF Client and DUT

Test Procedure:

1. Start an ONVIF Client.
2. Start the DUT.
3. Get complete list of access points from the DUT (see [Annex A.1](#)).
4. ONVIF Client will invoke **GetServiceCapabilities** request to retrieve MaxLimit capability.
5. Verify the **GetServiceCapabilitiesResponse** message from the DUT.
6. ONVIF Client will invoke **GetAccessPointInfo** request (invalid Token).
7. Verify the **GetAccessPointInfoResponse** message from the DUT. Check that empty list was returned.
8. ONVIF Client will invoke **GetAccessPointInfo** request (invalid Token, valid Token).
9. Verify the **GetAccessPointInfoResponse** message from the DUT. Check that list which contains AccessPoint for valid Token only was returned.

Test Result:

PASS –

- DUT passes all assertions.

FAIL –

- The DUT did not send valid **GetAccessPointInfoResponse** message.
- The DUT returned **GetAccessPointInfoResponse** message that contains at least two AccessPointInfo items with equal tokens.
- The DUT did not send valid **GetAccessPointInfoResponse** message.
- The DUT returned **GetAccessPointInfoResponse** message that contains any AccessPointInfo items for step [7](#).
- The DUT returned **GetAccessPointInfoResponse** message that contains any AccessPointInfo items other than item for valid Token or does not contains AccessPointInfo item for valid token step [8](#).

- The DUT did not return at least one Access Point at step 3.
- The DUT did not send valid **GetServiceCapabilitiesResponse**.

Note: If MaxLimit is less than 2 skip steps 8-9.

4.2.3 GET ACCESS POINT INFO LIST – LIMIT

Test Case ID: ACCESSCONTROL-2-1-3

Specification Coverage: GetAccessPointInfoList (ONVIF Access Control Service Specification)

Feature Under Test: GetAccessPointInfoList

WSDL Reference: accesscontrol.wsdl

Test Purpose: To verify Get Access Point Info List using Limit.

Pre-Requirement: Access Control Service was received from the DUT. At least one Access Point is configured and added to the DUT.

Test Configuration: ONVIF Client and DUT

Test Procedure:

1. Start an ONVIF Client.
2. Start the DUT.
3. Get complete list of access points from the DUT (see [Annex A.1](#))
4. ONVIF Client will invoke **GetServiceCapabilities** request to retrieve MaxLimit capability.
5. Verify the **GetServiceCapabilitiesResponse** message from the DUT.
6. ONVIF Client will invoke **GetAccessPointInfoList** request (Limit = 1, no StartReference) to retrieve the first item on the list of Access Point Information from the DUT.
7. Verify the **GetAccessPointInfoListResponse** message from the DUT.
8. Verify that **GetAccessPointInfoListResponse** message at step 7 does not contain number of items greater than 1. Verify that **GetAccessPointInfoListResponse** message at step 5 does not contain number of items greater than MaxLimit.
9. ONVIF Client will invoke **GetAccessPointInfoList** request (Limit = MaxLimit, no StartReference) to retrieve the first part of Access Point Information list from the DUT and is limited by MaxLimit.

10. Verify the **GetAccessPointInfoListResponse** message from the DUT.
11. Verify that **GetAccessPointInfoListResponse** message at step 10 does not contain number of items greater than MaxLimit.
12. ONVIF Client will invoke **GetAccessPointInfoList** request (Limit = ItemNumber, no StartReference, where ItemNumber is between 1 and minimal value of MaxLimit and total number of access points) to retrieve sublist of Access Point Information limited by ItemNumber from the DUT.
13. Verify the **GetAccessPointInfoListResponse** message from the DUT.
14. Verify that **GetAccessPointInfoListResponse** message at step 13 does not contain number of items greater than ItemNumber. Verify that **GetAccessPointInfoListResponse** message at step 13 does not contain number of items greater than MaxLimit.

Test Result:**PASS –**

- DUT passes all assertions.

FAIL –

- The DUT did not send valid **GetAccessPointInfoListResponse** message.
- The DUT did not return at least one Access Point on step 3.
- The DUT returned more AccessPointInfo items in **GetAccessPointInfoListResponse** message than it was specified in Limit parameter.
- The DUT returned more AccessPointInfo items in **GetAccessPointInfoListResponse** message than MaxLimit.
- The DUT did not send valid **GetServiceCapabilitiesResponse**.

Note: If the DUT did not return any AccessPointInfo on complete list of access points at step 3, skip steps 4-14, fail test and go to the next test.

Note: In case MaxLimit is equal to 0, 1 will be used instead for request.

4.2.4 GET ACCESS POINT INFO LIST – START REFERENCE AND LIMIT

Test Case ID: ACCESSCONTROL-2-1-4

Specification Coverage: GetAccessPointInfoList (ONVIF Access Control Service Specification)

Feature Under Test: GetAccessPointInfoList

WSDL Reference: accesscontrol.wsdl

Test Purpose: To verify Get Access Point Info List using StartReference and Limit.

Pre-Requisite: Access Control Service was received from the DUT. At least one Access Point is configured and added to the DUT.

Test Configuration: ONVIF Client and DUT

Test Procedure:

1. Start an ONVIF Client.
2. Start the DUT.
3. ONVIF Client will invoke **GetServiceCapabilities** request to retrieve DUT access control service capabilities.
4. Verify the **GetServiceCapabilitiesResponse** (MaxLimit) message from the DUT.
5. ONVIF Client will invoke **GetAccessPointInfoList** request (Limit = MaxLimit, no StartReference) to retrieve the first part of Access Point Information list from the DUT.
6. Verify the **GetAccessPointInfoListResponse** message from the DUT. Verify that **GetAccessPointInfoListResponse** message does not contain number of items greater than Limit. Verify that **GetAccessPointInfoListResponse** message does not contain number of items greater than MaxLimit.
7. If **GetAccessPointInfoListResponse** message contains NextStartReference, repeat steps 5-6 with StartReference = [current NextStartReference]. Otherwise, skip other steps and finalize getting the complete access point list.
8. Verify that **GetAccessPointInfoListResponse** messages at step 6 does not contain AccessPointInfo items with the same tokens values all over the list, i.e. there shall be no **GetAccessPointInfoListResponse** messages containing the same value for AccessPointInfo items token.
9. ONVIF Client will invoke **GetAccessPointInfoList** request (Limit = 1, no StartReference) to retrieve the first part of Access Point Information list from the DUT.
10. Verify the **GetAccessPointInfoListResponse** message from the DUT. Verify that **GetAccessPointInfoListResponse** message does not contain number of items greater

- than Limit. Verify that **GetAccessPointInfoListResponse** message does not contain number of items greater than MaxLimit.
11. If **GetAccessPointInfoListResponse** message contains NextStartReference, repeat steps 9-12 with StartReference = [current NextStartReference]. Otherwise, skip other steps and finalize getting the complete access point list.
 12. Verify that **GetAccessPointInfoListResponse** messages at step 10 does not contain AccessPointInfo items with the same tokens values all over the list, i.e. there shall be no **GetAccessPointInfoListResponse** messages containing the same value for AccessPointInfo items token.
 13. Verify that the total list received during steps 5-7 has the same items as the list received during steps 9-11.
 14. ONVIF Client will invoke **GetAccessPointInfoList** request (Limit = [limit_value], no StartReference, where limit_value is between 1 and MaxLimit) to retrieve the first part of Access Point Information list from the DUT.
 15. Verify the **GetAccessPointInfoListResponse** message from the DUT. Verify that **GetAccessPointInfoListResponse** message does not contain number of items greater than Limit. Verify that **GetAccessPointInfoListResponse** message does not contain number of items greater than MaxLimit.
 16. If **GetAccessPointInfoListResponse** message contains NextStartReference, repeat steps 14-17 with StartReference = [current NextStartReference]. Otherwise, skip other steps and finalize getting the complete access point list.
 17. Verify that **GetAccessPointInfoListResponse** messages at step 15 does not contain AccessPointInfo items with the same tokens values all over the list, i.e. there shall be no **GetAccessPointInfoListResponse** messages containing the same value for AccessPointInfo items token.
 18. Verify that the total list received during steps 5-7 has the same items as the list received during steps 14-16.

Test Result:**PASS –**

- DUT passes all assertions.

FAIL –

- The DUT did not send valid **GetAccessPointInfoListResponse** message.

- The DUT returned **GetAccessPointInfoListResponse** message that contains wrong item list than requested according to StartReference and Limit values.
- The DUT returned **GetAccessPointInfoListResponse** messages for step 6 contains at least one pair of the same tokens for AccessPointInfo item all over the messages.
- The DUT returned **GetAccessPointInfoListResponse** messages for step 10 contains at least one pair of the same tokens for AccessPointInfo item all over the messages.
- The DUT returned **GetAccessPointInfoListResponse** messages for step 15 contains at least one pair of the same tokens for AccessPointInfo item all over the messages.
- The DUT returned more AccessPointInfo items in **GetAccessPointInfoListResponse** message than it was specified in Limit parameter.
- The DUT returned more AccessPointInfo items in **GetAccessPointInfoListResponse** message than MaxLimit.
- The DUT did not send valid **GetServiceCapabilitiesResponse**.

Note: In case MaxLimit is equal to 0, 1 will be used instead for request.

4.2.5 GET ACCESS POINT INFO LIST – NO LIMIT

Test Case ID: ACCESSCONTROL-2-1-5

Specification Coverage: GetAccessPointInfoList (ONVIF Access Control Service Specification)

Feature Under Test: GetAccessPointInfoList

WSDL Reference: accesscontrol.wsdl

Test Purpose: To verify Get Access Point Info List without using Limit.

Pre-Requisite: Access Control Service was received from the DUT. At least one Access Point is configured and added to the DUT.

Test Configuration: ONVIF Client and DUT

Test Procedure:

1. Start an ONVIF Client.
2. Start the DUT.
3. ONVIF Client will invoke **GetServiceCapabilities** request to retrieve DUT access control service capabilities.

4. Verify the **GetServiceCapabilitiesResponse** (MaxLimit) message from the DUT.
5. ONVIF Client will invoke **GetAccessPointInfoList** request (no Limit, no StartReference) to retrieve the first part of Access Point Information list from the DUT.
6. Verify the **GetAccessPointInfoListResponse** message from the DUT. Verify that **GetAccessPointInfoListResponse** message does not contain number of items greater than MaxLimit.
7. If **GetAccessPointInfoListResponse** message contains NextStartReference, repeat steps 5-6 with StartReference = [current NextStartReference]. Otherwise, skip other steps and finalize getting the complete access point list.
8. Verify that **GetAccessPointInfoListResponse** messages at step 6 does not contain AccessPointInfo items with the same tokens values all over the list, i.e. there shall be no **GetAccessPointInfoListResponse** messages containing the same value for AccessPointInfo items token.

Test Result:**PASS –**

- DUT passes all assertions.

FAIL –

- The DUT did not send valid **GetAccessPointInfoListResponse** message.
- The DUT returned **GetAccessPointInfoListResponse** message that contains wrong item list than requested according to StartReference and Limit values.
- The DUT returned **GetAccessPointInfoListResponse** messages for step 6 contains at least one pair of the same tokens for AccessPointInfo item all over the messages.
- The DUT returned more AccessPointInfo items in **GetAccessPointInfoListResponse** message than MaxLimit.
- The DUT did not send valid **GetServiceCapabilitiesResponse**.

4.2.6 GET ACCESS POINT INFO – TOO MANY ITEMS

Test Case ID: ACCESSCONTROL-2-1-6

Specification Coverage: GetAccessPointInfo (ONVIF Access Control Service Specification)

Feature Under Test: GetAccessPointInfo

WSDL Reference: accesscontrol.wsdl

Test Purpose: To verify Get Access Point Info in case if there a more items than MaxLimit in request.

Pre-Requisite: Access Control Service was received from the DUT. At least one Access Point is configured and added to the DUT.

Test Configuration: ONVIF Client and DUT

Test Procedure:

1. Start an ONVIF Client.
2. Start the DUT.
3. Get complete list of access points from the DUT (see [Annex A.1](#)).
4. ONVIF Client will invoke **GetServiceCapabilities** request to retrieve MaxLimit capability.
5. Verify the **GetServiceCapabilitiesResponse** message from the DUT.
6. If total number of access points is less than MaxLimit, skip other steps and go to the text test.
7. ONVIF Client will invoke **GetAccessPointInfo** request (Token list with subset of AccessPointInfo.token values from a complete list of access points at step 3 with token number greater than MaxLimit) to retrieve a subset of Access Point Information from the DUT.
8. The DUT will generate SOAP 1.2 fault message (**InvalidArgs/TooManyItems**).

Test Result:

PASS –

- DUT passes all assertions.

FAIL –

- The DUT did not send SOAP 1.2 fault message.
- The DUT sent incorrect SOAP 1.2 fault message (fault code, namespace, etc.).
- The DUT did not send valid **GetServiceCapabilitiesResponse**.
- The DUT did not return at least one Access Point on step 3.

Note: If the DUT did not return any AccessPointInfo on complete list of access points at step 3, skip steps 4-8, fail test and go to the next test.

4.2.7 GET ACCESS POINT STATE

Test Case ID: ACCESSCONTROL-2-1-7

Specification Coverage: GetAccessPointState (ONVIF Access Control Service Specification)

Feature Under Test: GetAccessPointState

WSDL Reference: accesscontrol.wsdl

Test Purpose: To verify Get Access Point State.

Pre-Requisite: Access Control Service was received from the DUT. At least one Access Point is configured and added to the DUT.

Test Configuration: ONVIF Client and DUT

Test Procedure:

1. Start an ONVIF Client.
2. Start the DUT.
3. Get a complete list of access points from the DUT (see [Annex A.1](#)).
4. ONVIF Client will invoke **GetAccessPointState** request (TokenList.Token = Token1, where Token1 is the first token from the complete list of access points at step 3) to retrieve Access Point state for specified token from the DUT.
5. Verify the **GetAccessPointStateResponse** message from the DUT. Check that AccessPointState.Enabled is equal to true, if Access Point does not supports DisableAccessPoint capability, e.g. AccessPointInfo.Capabilities.DisableAccessPoint = false.
6. Repeat steps 4-5 for all other tokens from complete list of access points at step 3.

Test Result:

PASS –

- DUT passes all assertions.

FAIL –

- The DUT did not send valid **GetAccessPointStateResponse** message.
- The DUT did not return at least one Access Point on step 3.

- The DUT returned `AccessPointState.Enabled = false` for at least one Access Point in case `AccessPointInfo.Capabilities.DisableAccessPoint = false` for this Access Point.

Note: If the DUT did not return any `AccessPointInfo` on complete list of access points at step 3, skip steps 4-6, fail the test and go to the next test.

4.2.8 GET ACCESS POINT STATE WITH INVALID TOKEN

Test Case ID: ACCESSCONTROL-2-1-8

Specification Coverage: `GetAccessPointState` (ONVIF Access Control Service Specification)

Feature Under Test: `GetAccessPointState`

WSDL Reference: `accesscontrol.wsdl`

Test Purpose: To verify `Get Access Point State` with invalid Token.

Pre-Requisite: Access Control Service address was received from the DUT.

Test Configuration: ONVIF Client and DUT

Test Procedure:

1. Start an ONVIF Client.
2. Start the DUT.
3. ONVIF Client will invoke **`GetAccessPointState`** request (invalid Token).
4. The DUT will generate SOAP 1.2 fault message (**`InvalidArgVal/NotFound`**).

Test Result:

PASS –

- DUT passes all assertions.

FAIL –

- The DUT did not send SOAP 1.2 fault message.
- The DUT sent incorrect SOAP 1.2 fault message (fault code, namespace, etc.).

Note: Other faults than specified in the test are acceptable, but the specified are preferable.

4.2.9 ENABLE/DISABLE ACCESS POINT

Test Case ID: ACCESSCONTROL-2-1-9

Specification Coverage: EnableAccessPoint (ONVIF Access Control Service Specification), DisableAccessPoint (ONVIF Access Control Service Specification), GetAccessPointState (ONVIF Access Control Service Specification)

Feature Under Test: EnableAccessPoint, DisableAccessPoint, GetAccessPointState

WSDL Reference: accesscontrol.wsdl

Test Purpose: To verify that Enable and Disable Access Point and its State Change.

Pre-Requisite: Access Control Service was received from the DUT. At least one Access Point with Enable/Disable capability equal to true is configured and added to the DUT.

Test Configuration: ONVIF Client and DUT

Test Procedure:

1. Start an ONVIF Client.
2. Start the DUT.
3. Get complete list of access points from the DUT (see [Annex A.1](#)).
4. If there is no Access Points with DisableAccessPoint equal to true, fail the test and skip other steps.
5. If Access Point with Token1 (Token1 is the first AccessPointInfo.token from the complete list of access points at step 3) has AccessPointInfo.Capabilities.DisableAccessPoint equal to false, then skip steps 6-29 and go to the step 30.
6. ONVIF Client will invoke **GetAccessPointState** request (Token = "Token1", where Token1 is the first AccessPointInfo.token from the complete list of access points at step 3) to get current access point state.
7. Verify the **GetAccessPointStateResponse** message from the DUT.
8. If Access Point with Token1 (Token1 is the first AccessPointState.token from the complete list of access points at step 3) has AccessPointState.Enabled equal to true, then skip steps 9-19 and go to the step 20.
9. ONVIF Client will invoke **EnableAccessPoint** request (Token = "Token1", where Token1 is the first AccessPointInfo.token from the complete list of access points at step 3) to try enabling access point.
10. Verify the **EnableAccessPointResponse** message from the DUT.

11. ONVIF Client will invoke **GetAccessPointState** request (Token = "Token1", where Token1 is the first AccessPointInfo.token from the complete list of access points at step 3) to get current access point state.
12. Verify the **GetAccessPointStateResponse** message from the DUT.
13. Verify that AccessPointState.Enabled is equal to true.
14. ONVIF Client will invoke **DisableAccessPoint** request (Token = "Token1", where Token1 is the first AccessPointInfo.token from the complete list of access points at step 3) to try disabling access point.
15. Verify the **DisableAccessPointResponse** message from the DUT.
16. ONVIF Client will invoke **GetAccessPointState** request (Token = "Token1", where Token1 is the first AccessPointInfo.token from the complete list of access points at step 3) to get current access point state.
17. Verify the **GetAccessPointStateResponse** message from the DUT.
18. Verify that AccessPointState.Enabled is present and equal to false.
19. Go to step 30.
20. ONVIF Client will invoke **DisableAccessPoint** request (Token = "Token1", where Token1 is the first AccessPointInfo.token from the complete list of access points at step 3) to try disabling access point.
21. Verify the **DisableAccessPointResponse** message from the DUT.
22. ONVIF Client will invoke **GetAccessPointState** request (Token = "Token1", where Token1 is the first AccessPointInfo.token from the complete list of access points at step 3) to get current access point state.
23. Verify the **GetAccessPointStateResponse** message from the DUT.
24. Verify that AccessPointState.Enabled is present and equal to false.
25. ONVIF Client will invoke **EnableAccessPoint** request (Token = "Token1", where Token1 is the first AccessPointInfo.token from the complete list of access points at step 3) to try enabling access point.
26. Verify the **EnableAccessPointResponse** message from the DUT.
27. ONVIF Client will invoke **GetAccessPointState** request (Token = "Token1", where Token1 is the first AccessPointInfo.token from the complete list of access points at step 3) to get current access point state.

28. Verify the **GetAccessPointStateResponse** message from the DUT.
29. Verify that AccessPointState.Enabled is equal to true or skipped.
30. Repeat steps 5-29 for all other tokens from the complete list of access points at step 3.

Test Result:**PASS –**

- DUT passes all assertions.

FAIL –

- The DUT did not send valid **GetAccessPointStateResponse** message.
- The DUT did not send valid **EnableAccessPointResponse** message.
- The DUT did not send valid **DisableAccessPointResponse** message.
- The DUT did not change Access Point Enabled value to false after **DisableAccessPointResponse** message.
- The DUT did not change Access Point Enabled value to true after **EnableAccessPointResponse** message (Enabled element could be skipped in **GetAccessPointStateResponse** message for this case).
- The DUT did not return at least one Access Point at step 3.

Note: If the DUT did not return any AccessPointInfo on complete list of access points at step 3, skip steps 5-30, fail the test and go to the next test.

4.2.10 ENABLE/DISABLE ACCESS POINT - COMMAND NOT SUPPORTED

Test Case ID: ACCESSCONTROL-2-1-10

Specification Coverage: EnableAccessPoint (ONVIF Access Control Service Specification), DisableAccessPoint (ONVIF Access Control Service Specification)

Feature Under Test: EnableAccessPoint, DisableAccessPoint

WSDL Reference: accesscontrol.wsdl

Test Purpose: To verify that Enable and Disable Access Point in case Door does not support this capability.

Pre-Requisite: Access Control Service was received from the DUT. At least one Access Point is configured and added to the DUT. At least one Access Point with Enable/Disable capability equal to false is configured and added to the DUT, if possible.

Test Configuration: ONVIF Client and DUT

Test Procedure:

1. Start an ONVIF Client.
2. Start the DUT.
3. Get a complete list of access points from the DUT (see [Annex A.1](#)).
4. If Access Point with Token1 (Token1 is the first AccessPointInfo.token from the complete list of access points at step 3) has AccessPointInfo.Capabilities.DisableAccessPoint equal to true or skipped, then skip steps 5-8 and go to the step 9.
5. ONVIF Client will invoke **EnableAccessPoint** request (Token = "Token1", where Token1 is the first AccessPointInfo.token from the complete list of access points at step 3) to try enabling access point.
6. The DUT will generate SOAP 1.2 fault message (**ActionNotSupported/NotSupported**).
7. ONVIF Client will invoke **DisableAccessPoint** request ("Token1", where Token1 is the first AccessPointInfo.token from the complete list of access points at step 3) to try disabling access point.
8. The DUT will generate SOAP 1.2 fault message (**ActionNotSupported/NotSupported**).
9. Repeat steps 4-8 for all other tokens from the complete list of access points at step 3.

Test Result:

PASS –

- DUT passes all assertions.

FAIL –

- The DUT did not send SOAP 1.2 fault message.
- The DUT sent incorrect SOAP 1.2 fault message (fault code, namespace, etc.).
- The DUT did not return at least one Access Point on step 3.

Note: If the DUT did not return any AccessPointInfo on complete list of access points at step 3, skip steps 4-9, fail the test and go to the next test.

Note: Other faults than specified in the test are acceptable, but the specified are preferable.

4.2.11 ENABLE ACCESS POINT WITH INVALID TOKEN

Test Case ID: ACCESSCONTROL-2-1-11

Specification Coverage: EnableAccessPoint (ONVIF Access Control Service Specification)

Feature Under Test: EnableAccessPoint

WSDL Reference: accesscontrol.wsdl

Test Purpose: To verify Enable Access Point with invalid Token.

Pre-Requirement: Access Control Service address was received from the DUT.

Test Configuration: ONVIF Client and DUT

Test Procedure:

1. Start an ONVIF Client.
2. Start the DUT.
3. ONVIF Client will invoke **EnableAccessPoint** request (invalid Token).
4. The DUT will generate SOAP 1.2 fault message (**InvalidArgVal/NotFound**).

Test Result:

PASS –

- DUT passes all assertions.

FAIL –

- The DUT did not send SOAP 1.2 fault message.
- The DUT sent incorrect SOAP 1.2 fault message (fault code, namespace, etc.).

Note: Other faults than specified in the test are acceptable, but the specified are preferable.

4.2.12 DISABLE ACCESS POINT WITH INVALID TOKEN

Test Case ID: ACCESSCONTROL-2-1-12

Specification Coverage: DisableAccessPoint (ONVIF Access Control Service Specification)

Feature Under Test: DisableAccessPoint

WSDL Reference: accesscontrol.wsdl

Test Purpose: To verify Disable Access Point with invalid Token.

Pre-Requisite: Access Control Service address was received from the DUT.

Test Configuration: ONVIF Client and DUT

Test Procedure:

1. Start an ONVIF Client.
2. Start the DUT.
3. ONVIF Client will invoke **DisableAccessPoint** request (invalid Token).
4. The DUT will generate SOAP 1.2 fault message (**InvalidArgVal/NotFound**).

Test Result:

PASS –

- DUT passes all assertions.

FAIL –

- The DUT did not send SOAP 1.2 fault message.
- The DUT sent incorrect SOAP 1.2 fault message (fault code, namespace, etc.).

Note: Other faults than specified in the test are acceptable, but the specified are preferable.

4.3 Area

4.3.1 GET AREA INFO

Test Case ID: ACCESSCONTROL-3-1-1

Specification Coverage: GetAreaInfo (ONVIF Access Control Service Specification)

Feature Under Test: GetAreaInfo

WSDL Reference: accesscontrol.wsdl

Test Purpose: To verify Get Area Info.

Pre-Requisite: Access Control Service was received from the DUT. At least one Area is configured and added to the DUT, if the DUT allows this.

Test Configuration: ONVIF Client and DUT

Test Procedure:

1. Start an ONVIF Client.
2. Start the DUT.
3. Get the complete list of areas from the DUT (see [Annex A.2](#)).
4. ONVIF Client will invoke **GetServiceCapabilities** request to retrieve MaxLimit capability.
5. Verify the **GetServiceCapabilitiesResponse** message from the DUT.
6. ONVIF Client will invoke **GetAreaInfo** request (Token list with subset of AreaInfo.token values from the complete list of areas at step 3 with token number equal to MaxLimit) to retrieve subset of Area Information from the DUT.
7. Verify the **GetAreaInfoResponse** message from the DUT.
8. Verify that all requested AreaInfo items are in **GetAreaInfoResponse** message.
9. ONVIF Client will invoke **GetAreaInfo** request (Token = Token1, where Token1 is the first token from the complete list of areas at step 3) to retrieve Area Information for specified token from the DUT.
10. Verify the **GetAreaInfoResponse** message from the DUT.
11. Verify that **GetAreaInfoResponse** message contains AreaInfo only for specified token.
12. Repeat steps 9-11 for all other tokens from complete list of areas at step 3.

Test Result:

PASS –

- DUT passes all assertions.

FAIL –

- The DUT did not send valid **GetAreaInfoResponse** message.
- The DUT returned **GetAreaInfoResponse** message that contains at least two AreaInfo items with equal tokens.

- The DUT did not return requested AreaInfo items in **GetAreaInfoResponse** message for step 7 or 10.
- The DUT returned more items than requested in **GetAreaInfoResponse** message for step 7 or 10.
- The DUT did not send valid **GetServiceCapabilitiesResponse**.

Note: If the DUT did not return any AreaInfo on complete list of areas at step 3, skip steps 4-12 and go to the next test.

Note: In case MaxLimit is equal to 0, 1 will be used instead in requests.

4.3.2 GET AREA INFO WITH INVALID TOKEN

Test Case ID: ACCESSCONTROL-3-1-2

Specification Coverage: GetAreaInfo (ONVIF Access Control Service Specification)

Feature Under Test: GetAreaInfo

WSDL Reference: accesscontrol.wsdl

Test Purpose: To verify Get Area Info with invalid Token.

Pre-Requirement: Access Control Service was received from the DUT. At least one Area is configured and added to the DUT, if the DUT allows this.

Test Configuration: ONVIF Client and DUT

Test Procedure:

1. Start an ONVIF Client.
2. Start the DUT.
3. Get complete list of access points from the DUT (see [Annex A.1](#)).
4. ONVIF Client will invoke **GetServiceCapabilities** request to retrieve MaxLimit capability.
5. Verify the **GetServiceCapabilitiesResponse** message from the DUT.
6. ONVIF Client will invoke **GetAreaInfo** request (invalid Token).
7. Verify the **GetAreaInfoResponse** message from the DUT. Check that empty list was returned.
8. ONVIF Client will invoke **GetAreaInfo** request (invalid Token, valid Token).

9. Verify the **GetAreaInfoResponse** message from the DUT. Check that list which contains Area for valid Token only was returned.

Test Result:**PASS –**

- DUT passes all assertions.

FAIL –

- The DUT did not send valid **GetAreaInfoResponse** message.
- The DUT returned **GetAreaInfoResponse** message that contains at least two AreaInfo items with equal tokens.
- The DUT did not send valid **GetAreaInfoResponse** message.
- The DUT returned **GetAreaInfoResponse** message that contains any AreaInfo items for step [7](#).
- The DUT returned **GetAreaInfoResponse** message that contains any AreaInfo items other than item for valid Token or does not contains AreaInfo item for valid token step [9](#).
- The DUT did not send valid **GetServiceCapabilitiesResponse**.

Note: If MaxLimit is less than 2, skip steps [8-9](#).

Note: If the DUT did not return any AreaInfo on complete list of areas at step [3](#), skip steps [8-9](#) and go to the next test.

4.3.3 GET AREA INFO LIST – LIMIT

Test Case ID: ACCESSCONTROL-3-1-4

Specification Coverage: GetAreaInfoList (ONVIF Access Control Service Specification)

Feature Under Test: GetAreaInfoList

WSDL Reference: accesscontrol.wsdl

Test Purpose: To verify Get Area Info List using Limit.

Pre-Requisite: Access Control Service was received from the DUT. At least one Area is configured and added to the DUT, if the DUT allows this.

Test Configuration: ONVIF Client and DUT

Test Procedure:

1. Start an ONVIF Client.
2. Start the DUT.
3. Get a complete list of areas from the DUT (see [Annex A.2](#))
4. ONVIF Client will invoke **GetServiceCapabilities** request to retrieve MaxLimit capability.
5. Verify the **GetServiceCapabilitiesResponse** message from the DUT.
6. ONVIF Client will invoke **GetAreaInfoList** request (Limit = 1, no StartReference) to retrieve the first item on the list of Area Information from the DUT.
7. Verify the **GetAreaInfoListResponse** message from the DUT.
8. Verify that **GetAreaInfoListResponse** message at step 7 does not contain number of items greater than 1. Verify that **GetAreaInfoListResponse** message at step 7 does not contain number of items greater than MaxLimit.
9. ONVIF Client will invoke **GetAreaInfoList** request (Limit = MaxLimit, no StartReference) to retrieve the first part list of Area Information from the DUT and is limited by MaxLimit.
10. Verify the **GetAreaInfoListResponse** message from the DUT.
11. Verify that **GetAreaInfoListResponse** message at step 10 does not contain number of items greater than MaxLimit.
12. ONVIF Client will invoke **GetAreaInfoList** request (Limit = ItemNumber, no StartReference, where ItemNumber between 1 and minimal value between MaxLimit and total number of areas) to retrieve sublist of Area Information, and is limited by ItemNumber from the DUT.
13. Verify the **GetAreaInfoListResponse** message from the DUT.
14. Verify that **GetAreaInfoListResponse** message at step 13 does not contain number of items greater than ItemNumber. Verify that **GetAreaInfoListResponse** message at step 13 does not contain number of items greater than MaxLimit.

Test Result:**PASS –**

- DUT passes all assertions.

FAIL –

- The DUT did not send valid **GetAreaInfoListResponse** message.

- The DUT returned **GetAreaInfoListResponse** message that contains wrong item list than requested according to Limit value and StartReference value.
- The DUT returned more AreaInfo items in **GetAreaInfoListResponse** message than it was specified in Limit parameter.
- The DUT returned more AreaInfo items in **GetAreaInfoListResponse** message than MaxLimit.
- The DUT did not send valid **GetServiceCapabilitiesResponse**.

Note: If the DUT did not return any AreaInfo on complete list of areas at step 3, skip steps 4-14 and go to the next test.

Note: In case MaxLimit is equal to 0, 1 will be used instead in requests.

4.3.4 GET AREA INFO LIST – START REFERENCE AND LIMIT

Test Case ID: ACCESSCONTROL-3-1-5

Specification Coverage: GetAreaInfoList (ONVIF Access Control Service Specification)

Feature Under Test: GetAreaInfoList

WSDL Reference: accesscontrol.wsdl

Test Purpose: To verify Get Area Info List using StartReference and Limit.

Pre-Requisite: Access Control Service was received from the DUT. At least one Area is configured and added to the DUT, if the DUT allows this.

Test Configuration: ONVIF Client and DUT

Test Procedure:

1. Start an ONVIF Client.
2. Start the DUT.
3. ONVIF Client will invoke **GetServiceCapabilities** request to retrieve area control service capabilities of the DUT.
4. Verify the **GetServiceCapabilitiesResponse** (MaxLimit) message from the DUT.
5. ONVIF Client will invoke **GetAreaInfoList** request (Limit = MaxLimit, no StartReference) to retrieve the first part of Area Information list from the DUT.

6. Verify the **GetAreaInfoListResponse** message from the DUT. Verify that **GetAreaInfoListResponse** message does not contain number of items greater than Limit. Verify that **GetAreaInfoListResponse** message does not contain number of items greater than MaxLimit.
7. If **GetAreaInfoListResponse** message contains NextStartReference, repeat steps 5-6 with StartReference = [current NextStartReference]. Otherwise, skip other steps and finalize getting complete area list.
8. Verify that **GetAreaInfoListResponse** messages at step 6 does not contain AreaInfo items with the same tokens values all over the list, i.e. there shall be no **GetAreaInfoListResponse** messages containing the same value for AreaInfo items token.
9. ONVIF Client will invoke **GetAreaInfoList** request (Limit = 1, no StartReference) to retrieve the first part of Area Information list from the DUT.
10. Verify the **GetAreaInfoListResponse** message from the DUT. Verify that **GetAreaInfoListResponse** message does not contain number of items greater than Limit. Verify that **GetAreaInfoListResponse** message does not contain number of items greater than MaxLimit.
11. If **GetAreaInfoListResponse** message contains NextStartReference, repeat steps 5-6 with StartReference = [current NextStartReference]. Otherwise, skip other steps and finalize getting complete area list.
12. Verify that **GetAreaInfoListResponse** messages at step 10 does not contain AreaInfo items with the same tokens values all over the list, i.e. there shall be no **GetAreaInfoListResponse** messages containing the same value for AreaInfo items token.
13. Verify that total list received during steps 5-7 has the same items as the list received during steps 9-11.
14. ONVIF Client will invoke **GetAreaInfoList** request (Limit = [limit_value], no StartReference, where limit_value is between 1 and MaxLimit) to retrieve the first part of Area Information list from the DUT.
15. Verify the **GetAreaInfoListResponse** message from the DUT. Verify that **GetAreaInfoListResponse** message does not contain number of items greater than Limit. Verify that **GetAreaInfoListResponse** message does not contain number of items greater than MaxLimit.
16. If **GetAreaInfoListResponse** message contains NextStartReference, repeat steps 5-6 with StartReference = [current NextStartReference]. Otherwise, skip other steps and finalize getting complete area list.

17. Verify that **GetArealInfoListResponse** messages at step 15 does not contain ArealInfo items with the same tokens values all over the list, i.e. there shall be no **GetArealInfoListResponse** messages containing the same value for ArealInfo items token.
18. Verify that total list received during steps 5-7 has the same items as the list received during steps 14-16.

Test Result:**PASS –**

- DUT passes all assertions.

FAIL –

- The DUT did not send valid **GetArealInfoListResponse** message.
- The DUT returned **GetArealInfoListResponse** message that contains wrong item list than requested according to Offset and StartReference values.
- The DUT returned **GetArealInfoListResponse** messages for step 6 contains at least one pair of the same tokens for ArealInfo item all over the messages.
- The DUT returned **GetArealInfoListResponse** messages for step 10 contains at least one pair of the same tokens for ArealInfo item all over the messages.
- The DUT returned **GetArealInfoListResponse** messages for step 15 contains at least one pair of the same tokens for ArealInfo item all over the messages.
- The DUT returned more ArealInfo items in **GetArealInfoListResponse** message than it was specified in Limit parameter.
- The DUT did not send valid **GetServiceCapabilitiesResponse**.

Note: In case MaxLimit is equal to 0, 1 will be used instead in requests.

4.3.5 GET AREA INFO – TOO MANY ITEMS

Test Case ID: ACCESSCONTROL-3-1-9

Specification Coverage: GetArealInfo (ONVIF Access Control Service Specification)

Feature Under Test: GetArealInfo

WSDL Reference: accesscontrol.wsdl

Test Purpose: To verify Get Area Info in case if there a more items than MaxLimit in request.

Pre-Requisite: Access Control Service was received from the DUT. At least one Area is configured and added to the DUT, if the DUT allows this.

Test Configuration: ONVIF Client and DUT

Test Procedure:

1. Start an ONVIF Client.
2. Start the DUT.
3. Get the complete list of areas from the DUT (see [Annex A.2](#)).
4. ONVIF Client will invoke **GetServiceCapabilities** request to retrieve MaxLimit capability.
5. Verify the **GetServiceCapabilitiesResponse** message from the DUT.
6. If total number of areas is less than MaxLimit, skip other steps and go to the text test.
7. ONVIF Client will invoke **GetAreaInfo** request (Token list with subset of AreaInfo.token values from a complete list of areas at step 3 with token number greater than MaxLimit) to retrieve a subset of Area Information from the DUT.
8. The DUT will generate SOAP 1.2 fault message (**InvalidArgs/TooManyItems**).

Test Result:

PASS –

- DUT passes all assertions.

FAIL –

- The DUT did not send SOAP 1.2 fault message.
- The DUT sent incorrect SOAP 1.2 fault message (fault code, namespace, etc.).
- The DUT did not send valid **GetServiceCapabilitiesResponse**.

Note: If the DUT did not return any AreaInfo on complete list of areas at step 3, skip steps 4-8 and go to the next test.

4.3.6 GET AREA INFO LIST – NO LIMIT

Test Case ID: ACCESSCONTROL-3-1-10

Specification Coverage: GetAreaInfoList (ONVIF Access Control Service Specification)

Feature Under Test: GetAreaInfoList

WSDL Reference: accesscontrol.wsdl

Test Purpose: To verify Get Area Info List without using Limit.

Pre-Requisite: Access Control Service was received from the DUT. At least one Area is configured and added to the DUT, if the DUT allows this.

Test Configuration: ONVIF Client and DUT

Test Procedure:

1. Start an ONVIF Client.
2. Start the DUT.
3. ONVIF Client will invoke **GetServiceCapabilities** request to retrieve DUT access control service capabilities.
4. Verify the **GetServiceCapabilitiesResponse** (MaxLimit) message from the DUT.
5. ONVIF Client will invoke **GetAreaInfoList** request (no Limit, no StartReference) to retrieve the first part of Area Information list from the DUT.
6. Verify the **GetAreaInfoListResponse** message from the DUT. Verify that **GetAreaInfoListResponse** message does not contain number of items greater than MaxLimit.
7. If **GetAreaInfoListResponse** message contains NextStartReference, repeat steps 5-6 with StartReference = [current NextStartReference]. Otherwise, skip other steps and finalize getting the complete area list.
8. Verify that **GetAreaInfoListResponse** messages at step 6 does not contain AreaInfo items with the same tokens values all over the list, i.e. there shall be no **GetAreaInfoListResponse** messages containing the same value for AreaInfo items token.

Test Result:

PASS –

- DUT passes all assertions.

FAIL –

- The DUT did not send valid **GetAreaInfoListResponse** message.
- The DUT returned **GetAreaInfoListResponse** message that contains wrong item list than requested according to StartReference and Limit values.

- The DUT returned **GetAreaInfoListResponse** messages for step 6 contains at least one pair of the same tokens for AreaInfo item all over the messages.
- The DUT returned more AreaInfo items in **GetAreaInfoListResponse** message than MaxLimit.
- The DUT did not send valid **GetServiceCapabilitiesResponse**.

4.4 External Authorization

4.4.1 ACCESS CONTROL – ACCESS GRANTED TO ANONYMOUS (EXTERNAL AUTHORIZATION)

Test Case ID: ACCESSCONTROL-11-1-1

Specification Coverage: tns1:AccessControl/AccessGranted/Anonymous (Access Control Service Specification), tns1:AccessControl/Request/Anonymous (Access Control Service Specification), GetAccessPointInfoList (ONVIF Access Control Service Specification), ExternalAuthorization (ONVIF Access Control Service Specification)

Feature Under Test: ExternalAuthorization, tns1:AccessControl/AccessGranted/Anonymous, tns1:AccessControl/Request/Anonymous.

WSDL Reference: event.wsdl, accesscontrol.wsdl

Test Purpose: To verify Access Granted to Anonymous scenario in the case of External Authorization.

Pre-Requisite: Event Service was received from the DUT. Access Control Service was received from the DUT. At least one Access Point with External Authorization capability and Anonymous Access capability is configured and added to the DUT.

Test Configuration: ONVIF Client and DUT

Test Procedure:

1. Start an ONVIF Client.
2. Start the DUT.
3. Get complete list of access points from the DUT (see [Annex A.1](#)).
4. If there are no Access Points with Capabilities.AnonymousAccess = "true" and Capabilities.ExternalAuthorization = "true" in complete list of access points, fail the test and skip other steps.

5. ONVIF Client will invoke **GetEventProperties** request to retrieve all events supported by the DUT.
6. Verify the **GetEventPropertiesResponse** message from the DUT.
7. Check if there is an event with Topic `tns1:AccessControl/AccessGranted/Anonymous`. If there is no event with such Topic skip other steps, fail the test and go to the next test.
8. Check that this event is not a Property event (`MessageDescription.IsProperty = "false"`).
9. Check that this event contains `Source.SimpleItemDescription` item with `Name = "AccessPointToken"` and `Type = "pt:ReferenceToken"`.
10. Check that this event contains `Data.SimpleItemDescription` item with `Name = "External"` and `Type = "xs:boolean"`.
11. Check if there is an event with Topic `tns1:AccessControl/Request/Anonymous`. If there is no event with such Topic skip other steps, fail the test and go to the next test.
12. Check that this event is not a Property event (`MessageDescription.IsProperty = "false"`).
13. Check that this event contains `Source.SimpleItemDescription` item with `Name = "AccessPointToken"` and `Type = "pt:ReferenceToken"`.
14. ONVIF Client will invoke **CreatePullPointSubscription** request with `tns1:AccessControl/Request/Anonymous` Topic and `tns1:AccessControl/AccessGranted/Anonymous` Topic as Filter and an `InitialTerminationTime` of `timeout1`.
15. Verify that the DUT sends a **CreatePullPointSubscriptionResponse** message.
16. Test Operator will invoke `tns1:AccessControl/Request/Anonymous` event for any Access Points with `Capabilities.AnonymousAccess = "true"` and `Capabilities.ExternalAuthorization = "true"`.
17. ONVIF Client will invoke **PullMessages** request with a `PullMessagesTimeout` of 20s and a `MessageLimit` of 1.
18. Verify that the DUT sends a **PullMessagesResponse** that contains one `NotificationMessage`. If no `NotificationMessage` were received repeat step 17.
19. Verify received `Notification` message (correct value for UTC time, `TopicExpression` and `wsnt:Message`).
20. Verify that `TopicExpression` is equal to `tns1:AccessControl/Request/Anonymous` for the `Notification` message.

21. Verify that the Notification message contains Source.SimpleItem item with Name = "AccessPointToken" and Value is equal to one of existing Access Point Tokens Capabilities.AnonymousAccess = "true" and Capabilities.ExternalAuthorization = "true" (e.g. complete list of access points contains Access Point with the same token and this Access Point has Capabilities.AnonymousAccess = "true" and Capabilities.ExternalAuthorization = "true").
22. ONVIF Client will invoke **ExternalAuthorization** request (AccessPointToken from Notification message, no CredentialToken, Reason = "Test Access Granted", Decision = "Granted") to Grant Access for Anonymous.
23. Verify that the DUT sends **ExternalAuthorizationResponse** message.
24. ONVIF Client will invoke **PullMessages** request with a PullMessagesTimeout of 20s and a MessageLimit of 1.
25. Verify that the DUT sends a **PullMessagesResponse** that contains one NotificationMessage. If no NotificationMessage were received repeat step 24.
26. Verify that TopicExpression is equal to tns1:AccessControl/AccessGranted/Anonymous for the Notification message.
27. Verify received Notification message (correct value for UTC time, TopicExpression and wsnt:Message).
28. Verify that the notification contains Source.SimpleItem item with Name = "AccessPointToken" and Value is equal to Access Point Token from tns1:AccessControl/Request/Anonymous notification message.
29. Verify that the notification contains Data.SimpleItem item with Name = "External" and its Value is equal to "true".

Test Result:**PASS –**

- DUT passes all assertions.

FAIL –

- The DUT did not send a **GetEventPropertiesResponse**
- The DUT did not send **CreatePullPointSubscriptionResponse** message.
- The DUT did not send **ExternalAuthorizationResponse** message.

- The DUT did not send a **PullMessagesResponse** message that contains one tns1:AccessControl/Request/Anonymous event at step 18.
- The DUT did not send a **PullMessagesResponse** message that contains one tns1: tns1:AccessControl/AccessGranted/Anonymous event at step 25.
- The DUT sent an invalid Notification message (no corresponding Source.SimpleItem or Data.SimpleItem, wrong type of Value fields, invalid AccessPointToken value, invalid External value for tns1:AccessControl/AccessGranted/Anonymous notification message).
- The DUT did not return at least one Access Point on step 3.
- The DUT did not return valid Topic tns1:AccessControl/AccessGranted/Anonymous in **GetEventPropertiesResponse**.
- The DUT did not return valid Topic tns1:AccessControl/Request/Anonymous in **GetEventPropertiesResponse**.

Note: The Subscription Manager has to be deleted at the end of the test either by calling unsubscribe or through a timeout.

Note: The **Renew** has to be used for renew subscription during test, if InitialTerminationTime expires.

Note: Test will be failed, if no Notification message is received for step 18 or 25 during a certain period of time (Operation Delay should be used in ONVIF Device Test Tool).

Note: If DUT cannot accept the set value to Timeout or MessageLimit, ONVIF Client retries to send the PullMessage message with Timeout and MessageLimit which is contained in PullMessagesFaultResponse.

Note: If DUT cannot accept the set value to a TerminationTime, ONVIF Client retries to send the **Renew** request MinimumTime value which is contained in UnacceptableTerminationTimeFault.

Note: timeout1 will be taken from Subscription Timeout field of ONVIF Device Test Tool.

4.4.2 ACCESS CONTROL – ACCESS DENIED TO ANONYMOUS (EXTERNAL AUTHORIZATION)

Test Case ID: ACCESSCONTROL-11-1-2

Specification Coverage: tns1:AccessControl/Denied/Anonymous (Access Control Service Specification), tns1:AccessControl/Request/Anonymous (Access Control Service Specification), GetAccessPointInfoList (ONVIF Access Control Service Specification), ExternalAuthorization (ONVIF Access Control Service Specification)

Feature Under Test: ExternalAuthorization, tns1:AccessControl/Denied/Anonymous, tns1:AccessControl/Request/Anonymous.

WSDL Reference: event.wsdl, accesscontrol.wsdl

Test Purpose: To verify Access Denied to Anonymous scenario in the case of External Authorization.

Pre-Requirement: Event Service was received from the DUT. Access Control Service was received from the DUT. At least one Access Point with External Authorization capability and Anonymous Access capability is configured and added to the DUT.

Test Configuration: ONVIF Client and DUT

Test Procedure:

1. Start an ONVIF Client.
2. Start the DUT.
3. Get complete list of access points from the DUT (see [Annex A.1](#)).
4. If there are no Access Points with Capabilities.AnonymousAccess = "true" and Capabilities.ExternalAuthorization = "true" in complete list of access points, fail the test and skip other steps.
5. ONVIF Client will invoke **GetEventProperties** request to retrieve all events supported by the DUT.
6. Verify the **GetEventPropertiesResponse** message from the DUT.
7. Check if there is an event with Topic tns1:AccessControl/Denied/Anonymous. If there is no event with such Topic skip other steps, fail the test and go to the next test.
8. Check that this event is not a Property event (MessageDescription.IsProperty = "false").
9. Check that this event contains Source.SimpleItemDescription item with Name = "AccessPointToken" and Type = "pt:ReferenceToken".
10. Check that this event contains Data.SimpleItemDescription item with Name = "External" and Type = "xs:boolean".
11. Check that this event contains Data.SimpleItemDescription item with Name = "Reason" and Type = "xs:string".
12. ONVIF Client will invoke **CreatePullPointSubscription** request with tns1:AccessControl/Request/Anonymous Topic and tns1:AccessControl/Denied/Anonymous Topic as Filter and an InitialTerminationTime of timeout1.

13. Verify that the DUT sends a **CreatePullPointSubscriptionResponse** message.
14. Test Operator will invoke tns1:AccessControl/Request/Anonymous event for any Access Points with Capabilities.AnonymousAccess = "true" and Capabilities.ExternalAuthorization = "true".
15. ONVIF Client will invoke **PullMessages** request with a PullMessagesTimeout of 20s and a MessageLimit of 1.
16. Verify that the DUT sends a **PullMessagesResponse** that contains one NotificationMessage. If no NotificationMessage were received repeat step 15.
17. Verify received Notification message (correct value for UTC time, TopicExpression and wsnt:Message).
18. Verify that TopicExpression is equal to tns1:AccessControl/Request/Anonymous for the Notification message.
19. Verify that the notification contains Source.SimpleItem item with Name = "AccessPointToken" and Value is equal to one of existing Access Point Tokens Capabilities.AnonymousAccess = "true" and Capabilities.ExternalAuthorization = "true" (e.g. complete list of access points contains Access Point with the same token and this Access Point has Capabilities.AnonymousAccess = "true" and Capabilities.ExternalAuthorization = "true").
20. ONVIF Client will invoke **ExternalAuthorization** request (AccessPointToken from Notification message, no CredentialToken, Reason = "Test Access Denied", Decision = "Denied") to Deny Access for Anonymous.
21. Verify that the DUT sends **ExternalAuthorizationResponse** message.
22. ONVIF Client will invoke **PullMessages** request with a PullMessagesTimeout of 20s and a MessageLimit of 1.
23. Verify that the DUT sends a **PullMessagesResponse** that contains one NotificationMessage. If no NotificationMessage were received repeat step 22.
24. Verify that TopicExpression is equal to tns1:AccessControl/Denied/Anonymous for the Notification message.
25. Verify received Notification message (correct value for UTC time, TopicExpression and wsnt:Message).
26. Verify that the notification contains Source.SimpleItem item with Name = "AccessPointToken" and Value is equal to Access Point Token from tns1:AccessControl/Request/Anonymous notification message.

27. Verify that the notification contains Data.SimpleItem item with Name = "External" and its Value is equal to "true".

28. Verify that the notification contains Data.SimpleItem item with Name = "Reason" contains Value with type is equal to xs:string. Check that Reason value is one of the following strings: "CredentialNotEnabled", "CredentialNotActive", "CredentialExpired", "InvalidPIN", "NotPermittedAtThisTime", "Unauthorized", "Other".

Test Result:

PASS –

- DUT passes all assertions.

FAIL –

- The DUT did not send a **GetEventPropertiesResponse**
- The DUT did not send **CreatePullPointSubscriptionResponse** message.
- The DUT did not send **ExternalAuthorizationResponse** message.
- The DUT did not send a **PullMessagesResponse** message that contains one tns1:AccessControl/Request/Anonymous event at step 16.
- The DUT did not send a **PullMessagesResponse** message that contains one tns1:AccessControl/Denied/Anonymous event at step 23.
- The DUT sent an invalid Notification message (no corresponding Source.SimpleItem or Data.SimpleItem, wrong type of Value fields, invalid AccessPointToken value invalid External or Reason value for tns1:AccessControl/Denied/Anonymous notification message).
- The DUT did not return at least one Access Point on step 3.
- The DUT did not return valid Topic tns1:AccessControl/Denied/Anonymous in **GetEventPropertiesResponse**.
- The DUT did not return valid Topic tns1:AccessControl/Request/Anonymous in **GetEventPropertiesResponse**.

Note: The Subscription Manager has to be deleted at the end of the test either by calling unsubscribe or through a timeout.

Note: The **Renew** has to be used for renew subscription during test, if InitialTerminationTime expires.

Note: Test will be failed, if no Notification message is received for step 16 or 23 during a certain period of time (Operation Delay should be used in ONVIF Device Test Tool).

Note: If DUT cannot accept the set value to Timeout or MessageLimit, ONVIF Client retries to send the PullMessage message with Timeout and MessageLimit which is contained in PullMessagesFaultResponse.

Note: If DUT cannot accept the set value to a TerminationTime, ONVIF Client retries to send the **Renew** request MinimumTime value which is contained in UnacceptableTerminationTimeFault.

Note: timeout1 will be taken from Subscription Timeout field of ONVIF Device Test Tool.

4.4.3 ACCESS CONTROL – ACCESS TIMEOUT TO ANONYMOUS (EXTERNAL AUTHORIZATION)

Test Case ID: ACCESSCONTROL-11-1-3

Specification Coverage: tns1:AccessControl/Request/Timeout (Access Control Service Specification), tns1:AccessControl/Request/Anonymous (Access Control Service Specification), GetAccessPointInfoList (ONVIF Access Control Service Specification), ExternalAuthorization (ONVIF Access Control Service Specification)

Feature Under Test: ExternalAuthorization, tns1:AccessControl/Request/Timeout, tns1:AccessControl/Request/Anonymous.

WSDL Reference: event.wsdl, accesscontrol.wsdl

Test Purpose: To verify Access Timeout to Anonymous scenario in the case of External Authorization.

Pre-Requisite: Event Service was received from the DUT. Access Control Service was received from the DUT. At least one Access Point with External Authorization capability and Anonymous Access capability is configured and added to the DUT.

Test Configuration: ONVIF Client and DUT

Test Procedure:

1. Start an ONVIF Client.
2. Start the DUT.
3. Get complete list of access points from the DUT (see [Annex A.1](#)).
4. If there are no Access Points with Capabilities.AnonymousAccess = "true" and Capabilities.ExternalAuthorization = "true" in complete list of access points, fail the test and skip other steps.

5. ONVIF Client will invoke **GetEventProperties** request to retrieve all events supported by the DUT.
6. Verify the **GetEventPropertiesResponse** message from the DUT.
7. Check if there is an event with Topic `tns1:AccessControl/Request/Timeout`. If there is no event with such Topic skip other steps, fail the test and go to the next test.
8. Check that this event is not a Property event (`MessageDescription.IsProperty = "false"`).
9. Check that this event contains `Source.SimpleItemDescription` item with `Name = "AccessPointToken"` and `Type = "pt:ReferenceToken"`.
10. ONVIF Client will invoke **CreatePullPointSubscription** request with `tns1:AccessControl/Request/Anonymous` Topic and `tns1:AccessControl/Request/Timeout` Topic as Filter and an `InitialTerminationTime` of `timeout1`.
11. Verify that the DUT sends a **CreatePullPointSubscriptionResponse** message.
12. Test Operator will invoke `tns1:AccessControl/Request/Anonymous` event for any Access Points with `Capabilities.AnonymousAccess = "true"` and `Capabilities.ExternalAuthorization = "true"`.
13. ONVIF Client will invoke **PullMessages** request with a `PullMessagesTimeout` of 20s and a `MessageLimit` of 1.
14. Verify that the DUT sends a **PullMessagesResponse** that contains one `NotificationMessage`. If no `NotificationMessage` were received repeat step 13.
15. Verify received Notification message (correct value for UTC time, `TopicExpression` and `wsnt:Message`).
16. Verify that `TopicExpression` is equal to `tns1:AccessControl/Request/Anonymous` for the Notification message.
17. Verify that the notification contains `Source.SimpleItem` item with `Name = "AccessPointToken"` and `Value` is equal to one of existing Access Point Tokens `Capabilities.AnonymousAccess = "true"` and `Capabilities.ExternalAuthorization = "true"` (e.g. complete list of access points contains Access Point with the same token and this Access Point has `Capabilities.AnonymousAccess = "true"` and `Capabilities.ExternalAuthorization = "true"`).
18. ONVIF Client waits for timeout to initiate `tns1:AccessControl/Request/Timeout` event.
19. ONVIF Client will invoke **PullMessages** request with a `PullMessagesTimeout` of 20s and a `MessageLimit` of 1.

20. Verify that the DUT sends a **PullMessagesResponse** that contains one NotificationMessage. If no NotificationMessage were received repeat step 19.
21. Verify that TopicExpression is equal to tns1:AccessControl/Request/Timeout for the Notification message.
22. Verify received Notification message (correct value for UTC time, TopicExpression and wsnt:Message).
23. Verify that the notification contains Source.SimpleItem item with Name = "AccessPointToken" and Value is equal to Access Point Token from tns1:AccessControl/Request/Anonymous notification message.

Test Result:**PASS –**

- DUT passes all assertions.

FAIL –

- The DUT did not send a **GetEventPropertiesResponse**
- The DUT did not send **CreatePullPointSubscriptionResponse** message.
- The DUT did not send a **PullMessagesResponse** message that contains one tns1:AccessControl/Request/Anonymous event at step 14.
- The DUT did not send a **PullMessagesResponse** message that contains one tns1:tns1:AccessControl/Denied/Anonymous event at step 20.
- The DUT sent an invalid Notification message (no corresponding Source.SimpleItem or Data.SimpleItem, wrong type of Value fields, invalid AccessPointToken value).
- The DUT did not return at least one Access Point on step 3.
- The DUT did not return valid Topic tns1:AccessControl/Request/Timeout in **GetEventPropertiesResponse**.
- The DUT did not return valid Topic tns1:AccessControl/Request/Anonymous in **GetEventPropertiesResponse**.

Note: The Subscription Manager has to be deleted at the end of the test either by calling unsubscribe or through a timeout.

Note: The **Renew** has to be used for renew subscription during test, if InitialTerminationTime expires.

Note: Test will be failed, if no Notification message is received for step 16 or 23 during a certain period of time (Operation Delay should be used in ONVIF Device Test Tool).

Note: If DUT cannot accept the set value to Timeout or MessageLimit, ONVIF Client retries to send the PullMessage message with Timeout and MessageLimit which is contained in PullMessagesFaultResponse.

Note: If DUT cannot accept the set value to a TerminationTime, ONVIF Client retries to send the **Renew** request MinimumTime value which is contained in UnacceptableTerminationTimeFault.

Note: timeout1 will be taken from Subscription Timeout field of ONVIF Device Test Tool.

4.4.4 ACCESS CONTROL – ACCESS GRANTED WITH CREDENTIAL (EXTERNAL AUTHORIZATION)

Test Case ID: ACCESSCONTROL-11-1-4

Specification Coverage: tns1:AccessControl/AccessGranted/Credential (Access Control Service Specification), tns1:AccessControl/Request/Credential (Access Control Service Specification), GetAccessPointInfoList (ONVIF Access Control Service Specification), ExternalAuthorization (ONVIF Access Control Service Specification)

Feature Under Test: ExternalAuthorization, tns1:AccessControl/AccessGranted/Credential, tns1:AccessControl/Request/Credential.

WSDL Reference: event.wSDL, accesscontrol.wSDL

Test Purpose: To verify Access Granted with Credential scenario in the case of External Authorization.

Pre-Requisite: Event Service was received from the DUT. Access Control Service was received from the DUT. At least one Access Point with External Authorization capability is configured and added to the DUT.

Test Configuration: ONVIF Client and DUT

Test Procedure:

1. Start an ONVIF Client.
2. Start the DUT.
3. Get complete list of access points from the DUT (see [Annex A.1](#)).
4. If there are no Access Point with Capabilities.ExternalAuthorization = "true" in complete list of access points, fail the test and skip other steps.

5. ONVIF Client will invoke **GetEventProperties** request to retrieve all events supported by the DUT.
6. Verify the **GetEventPropertiesResponse** message from the DUT.
7. Check if there is an event with Topic `tns1:AccessControl/AccessGranted/Credential`. If there is no event with such Topic skip other steps, fail the test and go to the next test.
8. Check that this event is not a Property event (`MessageDescription.IsProperty = "false"`).
9. Check that this event contains `Source.SimpleItemDescription` item with `Name = "AccessPointToken"` and `Type = "pt:ReferenceToken"`.
10. Check that this event contains `Data.SimpleItemDescription` item with `Name = "CredentialToken"` and `Type = "pt:ReferenceToken"`.
11. Check that if this event contains `Data.SimpleItemDescription` item with `Name = "CredentialHolderName"`, than it has `Type = "xs:string"`.
12. Check that this event contains `Data.SimpleItemDescription` item with `Name = "External"` and `Type = "xs:boolean"`.
13. Check if there is an event with Topic `tns1:AccessControl/Request/Credential`. If there is no event with such Topic skip other steps, fail the test and go to the next test.
14. Check that this event is not a Property event (`MessageDescription.IsProperty = "false"`).
15. Check that this event contains `Source.SimpleItemDescription` item with `Name = "AccessPointToken"` and `Type = "pt:ReferenceToken"`.
16. Check that this event contains `Data.SimpleItemDescription` item with `Name = "CredentialToken"` and `Type = "pt:ReferenceToken"`.
17. Check that if this event contains `Data.SimpleItemDescription` item with `Name = "CredentialHolderName"`, than it has `Type = "xs:string"`.
18. ONVIF Client will invoke **CreatePullPointSubscription** request with `tns1:AccessControl/Request/Credential` Topic and `tns1:AccessControl/AccessGranted/Credential` Topic as Filter and an `InitialTerminationTime` of `timeout1`.
19. Verify that the DUT sends a **CreatePullPointSubscriptionResponse** message.
20. Test Operator will invoke `tns1:AccessControl/Request/Credential` event for any Access Points with `Capabilities.ExternalAuthorization = "true"`.
21. ONVIF Client will invoke **PullMessages** request with a `PullMessagesTimeout` of 20s and a `MessageLimit` of 1.

22. Verify that the DUT sends a **PullMessagesResponse** that contains one NotificationMessage. If no NotificationMessage were received repeat step 21.
23. Verify received Notification message (correct value for UTC time, TopicExpression and wsnt:Message).
24. Verify that TopicExpression is equal to tns1:AccessControl/Request/Credential for the Notification message.
25. Verify that the notification contains Source.SimpleItem item with Name = "AccessPointToken" and Value is equal to one of existing Access Point Tokens Capabilities.ExternalAuthorization = "true" (e.g. complete list of access points contains Access Point with the same token and this Access Point has Capabilities.ExternalAuthorization = "true").
26. Verify that the notification contains Data.SimpleItem item with Name = "CredentialToken" and Value with type is equal to pt:ReferenceToken.
27. Verify that the notification which contains Data.SimpleItem item with Name = "CredentialHolderName" contains Value with type is equal to xs:string.
28. ONVIF Client will invoke **ExternalAuthorization** request (AccessPointToken from Notification message, CredentialToken from Notification message, Reason = "Test Access Granted", Decision = "Granted") to Grant Access with Credential.
29. Verify that the DUT sends **ExternalAuthorizationResponse** message.
30. ONVIF Client will invoke **PullMessages** request with a PullMessagesTimeout of 20s and a MessageLimit of 1.
31. Verify that the DUT sends a **PullMessagesResponse** that contains one NotificationMessage. If no NotificationMessage were received repeat step 30.
32. Verify that TopicExpression is equal to tns1:AccessControl/AccessGranted/Credential for the Notification message.
33. Verify received Notification message (correct value for UTC time, TopicExpression and wsnt:Message).
34. Verify that the notification contains Source.SimpleItem item with Name = "AccessPointToken" and Value is equal to Access Point Token from tns1:AccessControl/Request/Credential notification message.
35. Verify that the notification contains Data.SimpleItem item with Name = "CredentialToken" and Value with type is equal to pt:ReferenceToken. Verify that this value is equal to the same Data.SimpleItem from tns1:AccessControl/Request/Credential notification.

36. Verify that the notification which contains Data.SimpleItem item with Name = "CredentialHolderName" contains Value with type is equal to xs:string. Verify that this value is equal to the same Data.SimpleItem from tns1:AccessControl/Request/Credential notification.

37. Verify that the notification contains Data.SimpleItem item with Name = "External" and its Value is equal to "true".

Test Result:

PASS –

- DUT passes all assertions.

FAIL –

- The DUT did not send a **GetEventPropertiesResponse**
- The DUT did not send **CreatePullPointSubscriptionResponse** message.
- The DUT did not send **ExternalAuthorizationResponse** message.
- The DUT did not send a **PullMessagesResponse** message that contains one tns1:AccessControl/Request/Credential event at step [22](#).
- The DUT did not send a **PullMessagesResponse** message that contains one tns1:AccessControl/AccessGranted/Anonymous event at step [31](#).
- The DUT sent an invalid Notification message (no corresponding Source.SimpleItem or Data.SimpleItem, wrong type of Value fields, invalid AccessPointToken value, invalid CredentialToken, invalid CredentialHolderName, invalid External value for tns1:AccessControl/AccessGranted/Credential notification message).
- The DUT did not return at least one Access Point on step [3](#).
- The DUT did not return valid Topic tns1:AccessControl/AccessGranted/Credential in **GetEventPropertiesResponse**.
- The DUT did not return valid Topic tns1:AccessControl/Request/Credential in **GetEventPropertiesResponse**.

Note: The Subscription Manager has to be deleted at the end of the test either by calling unsubscribe or through a timeout.

Note: The **Renew** has to be used for renew subscription during test, if InitialTerminationTime expires.

Note: Test will be failed, if no Notification message is received for step 22 or 31 during a certain period of time (Operation Delay should be used in ONVIF Device Test Tool).

Note: If DUT cannot accept the set value to Timeout or MessageLimit, ONVIF Client retries to send the PullMessage message with Timeout and MessageLimit which is contained in PullMessagesFaultResponse.

Note: If DUT cannot accept the set value to a TerminationTime, ONVIF Client retries to send the **Renew** request MinimumTime value which is contained in UnacceptableTerminationTimeFault.

Note: timeout1 will be taken from Subscription Timeout field of ONVIF Device Test Tool.

4.4.5 ACCESS CONTROL – ACCESS DENIED WITH CREDENTIAL (EXTERNAL AUTHORIZATION)

Test Case ID: ACCESSCONTROL-11-1-5

Specification Coverage: tns1:AccessControl/Denied/Credential (Access Control Service Specification), tns1:AccessControl/Request/Credential (Access Control Service Specification), GetAccessPointInfoList (ONVIF Access Control Service Specification), ExternalAuthorization (ONVIF Access Control Service Specification)

Feature Under Test: ExternalAuthorization, tns1:AccessControl/Denied/Credential, tns1:AccessControl/Request/Credential.

WSDL Reference: event.wSDL, accesscontrol.wSDL

Test Purpose: To verify Access Denied with Credential scenario in the case of External Authorization.

Pre-Requisite: Event Service was received from the DUT. Access Control Service was received from the DUT. At least one Access Point with External Authorization capability is configured and added to the DUT.

Test Configuration: ONVIF Client and DUT

Test Procedure:

1. Start an ONVIF Client.
2. Start the DUT.
3. Get complete list of access points from the DUT (see [Annex A.1](#)).
4. If there are no Access Point with and Capabilities.ExternalAuthorization = "true" in complete list of access points, fail the test and skip other steps.

5. ONVIF Client will invoke **GetEventProperties** request to retrieve all events supported by the DUT.
6. Verify the **GetEventPropertiesResponse** message from the DUT.
7. Check if there is an event with Topic `tns1:AccessControl/Denied/Credential`. If there is no event with such Topic skip other steps, fail the test and go to the next test.
8. Check that this event is not a Property event (`MessageDescription.IsProperty = "false"`).
9. Check that this event contains `Source.SimpleItemDescription` item with `Name = "AccessPointToken"` and `Type = "pt:ReferenceToken"`.
10. Check that this event contains `Data.SimpleItemDescription` item with `Name = "CredentialToken"` and `Type = "pt:ReferenceToken"`.
11. Check that if this event contains `Data.SimpleItemDescription` item with `Name = "CredentialHolderName"`, then it has `Type = "xs:string"`.
12. Check that this event contains `Data.SimpleItemDescription` item with `Name = "External"` and `Type = "xs:boolean"`.
13. Check that this event contains `Data.SimpleItemDescription` item with `Name = "Reason"` and `Type = "xs:string"`.
14. ONVIF Client will invoke **CreatePullPointSubscription** request with `tns1:AccessControl/Request/Credential` Topic and `tns1:AccessControl/Denied/Credential` Topic as Filter and an `InitialTerminationTime` of `timeout1`.
15. Verify that the DUT sends a **CreatePullPointSubscriptionResponse** message.
16. Test Operator will invoke `tns1:AccessControl/Request/Credential` event for any Access Points with `Capabilities.ExternalAuthorization = "true"`.
17. ONVIF Client will invoke **PullMessages** request with a `PullMessagesTimeout` of 20s and a `MessageLimit` of 1.
18. Verify that the DUT sends a **PullMessagesResponse** that contains one `NotificationMessage`. If no `NotificationMessage` were received repeat step 17.
19. Verify received `NotificationMessage` (correct value for UTC time, `TopicExpression` and `wsnt:Message`).
20. Verify that `TopicExpression` is equal to `tns1:AccessControl/Request/Credential` for the `NotificationMessage`.

21. Verify that the notification contains Source.SimpleItem item with Name = "AccessPointToken" and Value is equal to one of existing Access Point Tokens Capabilities.ExternalAuthorization = "true" (e.g. complete list of access points contains Access Point with the same token and this Access Point has Capabilities.ExternalAuthorization = "true").
22. Verify that the notification contains Data.SimpleItem item with Name = "CredentialToken" and Value with type is equal to pt:ReferenceToken.
23. Verify that the notification which contains Data.SimpleItem item with Name = "CredentialHolderName" contains Value with type is equal to xs:string.
24. ONVIF Client will invoke **ExternalAuthorization** request (AccessPointToken from Notification message, CredentialToken from Notification message, Reason = "Test Access Denied", Decision = "Denied") to Deny Access with Credential.
25. Verify that the DUT sends **ExternalAuthorizationResponse** message.
26. ONVIF Client will invoke **PullMessages** request with a PullMessagesTimeout of 20s and a MessageLimit of 1.
27. Verify that the DUT sends a **PullMessagesResponse** that contains one NotificationMessage. If no NotificationMessage were received repeat step 26.
28. Verify that TopicExpression is equal to tns1:AccessControl/Denied/Credential for the Notification message.
29. Verify received Notification message (correct value for UTC time, TopicExpression and wsnt:Message).
30. Verify that the notification contains Source.SimpleItem item with Name = "AccessPointToken" and Value is equal to Access Point Token from tns1:AccessControl/Request/Credential notification message.
31. Verify that the notification contains Data.SimpleItem item with Name = «CredentialToken» and Value with type is equal to pt:ReferenceToken. Verify that this value is equal to the same Data.SimpleItem from tns1:AccessControl/Request/Credential notification.
32. Verify that the notification which contains Data.SimpleItem item with Name = "CredentialHolderName" contains Value with type is equal to xs:string. Verify that this value is equal to the same Data.SimpleItem from tns1:AccessControl/Request/Credential notification.
33. Verify that the notification contains Data.SimpleItem item with Name = "External" and its Value is equal to "true".

34. Verify that the notification contains Data.SimpleItem item with Name = "Reason" contains Value with type is equal to xs:string. Check that Reason value is one of the following strings: "CredentialNotEnabled", "CredentialNotActive", "CredentialExpired", "InvalidPIN", "NotPermittedAtThisTime", "Unauthorized", "Other".

Test Result:**PASS –**

- DUT passes all assertions.

FAIL –

- The DUT did not send a **GetEventPropertiesResponse**
- The DUT did not send **CreatePullPointSubscriptionResponse** message.
- The DUT did not send **ExternalAuthorizationResponse** message.
- The DUT did not send a **PullMessagesResponse** message that contains one tns1:AccessControl/Request/Credential event at step 18.
- The DUT did not send a **PullMessagesResponse** message that contains one tns1:AccessControl/Denied/Anonymous event at step 27.
- The DUT sent an invalid Notification message (no corresponding Source.SimpleItem or Data.SimpleItem, wrong type of Value fields, invalid AccessPointToken value, invalid CredentialToken, invalid CredentialHolderName, invalid External value for tns1:AccessControl/Denied/Credential notification message).
- The DUT did not return at least one Access Point on step 3.
- The DUT did not return valid Topic tns1:AccessControl/Denied/Credential in **GetEventPropertiesResponse**.
- The DUT did not return valid Topic tns1:AccessControl/Request/Credential in **GetEventPropertiesResponse**.

Note: The Subscription Manager has to be deleted at the end of the test either by calling unsubscribe or through a timeout.

Note: The **Renew** has to be used for renew subscription during test, if InitialTerminationTime expires.

Note: Test will be failed, if no Notification message is received for at 18 or 27 during a certain period of time (Operation Delay should be used in ONVIF Device Test Tool).

Note: If DUT cannot accept the set value to Timeout or MessageLimit, ONVIF Client retries to send the PullMessage message with Timeout and MessageLimit which is contained in PullMessagesFaultResponse.

Note: If DUT cannot accept the set value to a TerminationTime, ONVIF Client retries to send the **Renew** request MinimumTime value which is contained in UnacceptableTerminationTimeFault.

Note: timeout1 will be taken from Subscription Timeout field of ONVIF Device Test Tool.

4.4.6 ACCESS CONTROL – ACCESS TIMEOUT WITH CREDENTIAL (EXTERNAL AUTHORIZATION)

Test Case ID: ACCESSCONTROL-11-1-6

Specification Coverage: tns1:AccessControl/Request/Timeout (Access Control Service Specification), tns1:AccessControl/Request/Credential (Access Control Service Specification), GetAccessPointInfoList (ONVIF Access Control Service Specification)

Feature Under Test: ExternalAuthorization, tns1:AccessControl/Request/Timeout, tns1:AccessControl/Request/Credential.

WSDL Reference: event.wsdl, accesscontrol.wsdl

Test Purpose: To verify Access Timeout with Credential scenario in the case of External Authorization.

Pre-Requisite: Event Service was received from the DUT. Access Control Service was received from the DUT. At least one Access Point with External Authorization capability is configured and added to the DUT.

Test Configuration: ONVIF Client and DUT

Test Procedure:

1. Start an ONVIF Client.
2. Start the DUT.
3. Get complete list of access points from the DUT (see [Annex A.1](#)).
4. If there are no Access Point with Capabilities.ExternalAuthorization = "true" in complete list of access points, fail the test and skip other steps.
5. ONVIF Client will invoke **GetEventProperties** request to retrieve all events supported by the DUT.

6. Verify the **GetEventPropertiesResponse** message from the DUT.
7. Check if there is an event with Topic `tns1:AccessControl/Request/Timeout`. If there is no event with such Topic skip other steps, fail the test and go to the next test.
8. Check that this event is not a Property event (`MessageDescription.IsProperty = "false"`).
9. Check that this event contains `Source.SimpleItemDescription` item with `Name = "AccessPointToken"` and `Type = "pt:ReferenceToken"`.
10. ONVIF Client will invoke **CreatePullPointSubscription** request with `tns1:AccessControl/Request/Credential` Topic and `tns1:AccessControl/Request/Timeout` Topic as Filter and an `InitialTerminationTime` of `timeout1`.
11. Verify that the DUT sends a **CreatePullPointSubscriptionResponse** message.
12. Test Operator will invoke `tns1:AccessControl/Request/Credential` event for any Access Points with `Capabilities.ExternalAuthorization = "true"`.
13. ONVIF Client will invoke **PullMessages** request with a `PullMessagesTimeout` of 20s and a `MessageLimit` of 1.
14. Verify that the DUT sends a **PullMessagesResponse** that contains one `NotificationMessage`. If no `NotificationMessage` were received repeat step 13.
15. Verify received `Notification` message (correct value for UTC time, `TopicExpression` and `wsnt:Message`).
16. Verify that `TopicExpression` is equal to `tns1:AccessControl/Request/Credential` for the `Notification` message.
17. Verify that the notification contains `Source.SimpleItem` item with `Name = "AccessPointToken"` and `Value` is equal to one of existing Access Point Tokens `Capabilities.ExternalAuthorization = "true"` (e.g. complete list of access points contains Access Point with the same token and this Access Point has `Capabilities.ExternalAuthorization = "true"`).
18. Verify that the notification contains `Data.SimpleItem` item with `Name = "CredentialToken"` and `Value` with type is equal to `pt:ReferenceToken`.
19. Verify that the notification which contains `Data.SimpleItem` item with `Name = "CredentialHolderName"` contains `Value` with type is equal to `xs:string`.
20. ONVIF Client waits for timeout to initiate `tns1:AccessControl/Request/Timeout` event.
21. ONVIF Client will invoke **PullMessages** request with a `PullMessagesTimeout` of 20s and a `MessageLimit` of 1.

22. Verify that the DUT sends a **PullMessagesResponse** that contains one NotificationMessage. If no NotificationMessage were received repeat step 21.
23. Verify that TopicExpression is equal to tns1:AccessControl/Request/Timeout for the Notification message.
24. Verify received Notification message (correct value for UTC time, TopicExpression and wsnt:Message).
25. Verify that the notification contains Source.SimpleItem item with Name = "AccessPointToken" and Value is equal to Access Point Token from tns1:AccessControl/Request/Credential notification message.

Test Result:**PASS –**

- DUT passes all assertions.

FAIL –

- The DUT did not send a **GetEventPropertiesResponse**
- The DUT did not send **CreatePullPointSubscriptionResponse** message.
- The DUT did not send a **PullMessagesResponse** message that contains one tns1:AccessControl/Request/Credential event at step 14.
- The DUT did not send a **PullMessagesResponse** message that contains one tns1:AccessControl/Request/Timeout event at step 22.
- The DUT sent an invalid Notification message (no corresponding Source.SimpleItem or Data.SimpleItem, wrong type of Value fields, invalid AccessPointToken value, invalid CredentialToken, invalid CredentialHolderName).
- The DUT did not return at least one Access Point on step 3.
- The DUT did not return valid Topic tns1:AccessControl/Request/Credential in **GetEventPropertiesResponse**.
- The DUT did not return valid Topic tns1:AccessControl/Request/Timeout in **GetEventPropertiesResponse**.

Note: The Subscription Manager has to be deleted at the end of the test either by calling unsubscribe or through a timeout.

Note: The **Renew** has to be used for renew subscription during test, if InitialTerminationTime expires.

Note: Test will be failed, if no Notification message is received for step 14 or 22 during a certain period of time (Operation Delay should be used in ONVIF Device Test Tool).

Note: If DUT cannot accept the set value to Timeout or MessageLimit, ONVIF Client retries to send the PullMessage message with Timeout and MessageLimit which is contained in PullMessagesFaultResponse.

Note: If DUT cannot accept the set value to a TerminationTime, ONVIF Client retries to send the **Renew** request MinimumTime value which is contained in UnacceptableTerminationTimeFault.

Note: timeout1 will be taken from Subscription Timeout field of ONVIF Device Test Tool.

4.4.7 EXTERNAL AUTHORIZATION WITH INVALID TOKEN

Test Case ID: ACCESSCONTROL-11-1-7

Specification Coverage: ExternalAuthorization (ONVIF Access Control Service Specification)

Feature Under Test: ExternalAuthorization

WSDL Reference: accesscontrol.wsdl

Test Purpose: To verify External Authorization with invalid Token.

Pre-Requisite: Access Control Service address was received from the DUT.

Test Configuration: ONVIF Client and DUT

Test Procedure:

1. Start an ONVIF Client.
2. Start the DUT.
3. ONVIF Client will invoke **ExternalAuthorization** request (invalid AccessPointToken).
4. The DUT will generate SOAP 1.2 fault message (**InvalidArgVal/NotFound**).

Test Result:

PASS –

- DUT passes all assertions.

FAIL –

- The DUT did not send SOAP 1.2 fault message.
- The DUT sent incorrect SOAP 1.2 fault message (fault code, namespace, etc.).

Note: Other faults than specified in the test are acceptable, but the specified are preferable.

4.4.8 EXTERNAL AUTHORIZATION – COMMAND NOT SUPPORTED

Test Case ID: ACCESSCONTROL-11-1-8

Specification Coverage: ExternalAuthorization (ONVIF Access Control Service Specification)

Feature Under Test: ExternalAuthorization

WSDL Reference: accesscontrol.wsdl

Test Purpose: To verify External Authorization in case Access Point does not support it.

Pre-Requisite: Access Control Service address was received from the DUT. At least one Access Point is configured without External Authorization capability and added to the DUT, if possible.

Test Configuration: ONVIF Client and DUT

Test Procedure:

1. Start an ONVIF Client.
2. Start the DUT.
3. Get complete list of access points from the DUT (see [Annex A.1](#)).
4. If Access Point with Token1 (Token1 is the first AccessPointInfo.token from the complete list of Access Points at step 3) has AccessPointInfo.Capabilities.ExternalAuthorization equal to true, then skip steps 5-6 and go to the step 7.
5. ONVIF Client will invoke **ExternalAuthorization** request (AccessPointToken = "Token1", where Token1 is the first AccessPointInfo.token from the complete list of doors at step 3) to try perform external authorization.
6. The DUT will generate SOAP 1.2 fault message (**ActionNotSupported/NotSupported**).
7. Repeat steps 4-6 for all other tokens from the complete list of Access Point at step 3.

Test Result:

PASS –

- DUT passes all assertions.

FAIL –

- The DUT did not send SOAP 1.2 fault message.
- The DUT did not return at least one Access Point on step 3.

Note: If the DUT does not return any Access Point for step 3, skip steps 4-7, fail the test and go to the next test.

Note: Other faults than specified in the test are acceptable, but the specified are preferable.

4.5 Property Events

4.5.1 ACCESS CONTROL – ACCESS POINT ENABLED EVENT

Test Case ID: ACCESSCONTROL-5-1-1

Specification Coverage: tns1:AccessPoint/State/Enabled (Access Control Service Specification), GetAccessPointState (ONVIF Access Control Service Specification), Properties (ONVIF Core Specification)

Feature Under Test: GetAccessPointState

WSDL Reference: event.wsdl, accesscontrol.wsdl

Test Purpose: To verify tns1:AccessPoint/State/Enabled event generation after subscription and to verify tns1:AccessPoint/State/Enabled event format.

Pre-Requirement: Event Service was received from the DUT. Access Control Service was received from the DUT. At least one Access Point with Enable/Disable capability is configured and added to the DUT.

Test Configuration: ONVIF Client and DUT

Test Procedure:

1. Start an ONVIF Client.
2. Start the DUT.
3. Get complete list of access points from the DUT (see [Annex A.1](#)).
4. If there is no Access Points with DisableAccessPoint equal to true, fail the test and skip other steps.
5. ONVIF Client will invoke **GetEventProperties** request to retrieve all events supported by the DUT.

6. Verify the **GetEventPropertiesResponse** message from the DUT.
7. Check if there is an event with Topic `tns1:AccessPoint/State/Enabled`. If there is no event with such Topic skip other steps, fail the test and go to the next test.
8. Check that this event is a Property event (`MessageDescription.IsProperty = "true"`).
9. Check that this event contains `Source.SimpleItemDescription` item with `Name = "AccessPointToken"` and `Type = "pt:ReferenceToken"`.
10. Check that this event contains `Data.SimpleItemDescription` item with `Name = "State"` and `Type = "xs:boolean"`.
11. ONVIF Client will invoke **CreatePullPointSubscription** request with `tns1:AccessPoint/State/Enabled` Topic as Filter and an `InitialTerminationTime` of `timeout1`.
12. Verify that the DUT sends a **CreatePullPointSubscriptionResponse** message.
13. ONVIF Client will invoke **PullMessages** request with a `PullMessagesTimeout` of 20s and a `MessageLimit` of 1.
14. Verify that the DUT sends a **PullMessagesResponse** that contains `NotificationMessages`. Repeat step 13 until Notification for all Access Points will be received.
15. Verify received Notification messages (correct value for UTC time, `TopicExpression` and `wsnt:Message`).
16. Verify that `TopicExpression` is equal to `tns1:AccessPoint/State/Enabled` for all received Notification messages.
17. Verify that each notification contains `Source.SimpleItem` item with `Name = "AccessPointToken"` and `Value` is equal to one of the existing Access Point Tokens (e.g. complete list of access points contains Access Point with the same token). Verify that there are Notification messages for each Access Point.
18. Verify that each notification contains `Data.SimpleItem` item with `Name = "State"` and `Value` with type is equal to `xs:boolean`.
19. Verify that `Notify PropertyOperation = "Initialized"`.
20. ONVIF Client will invoke **GetAccessPointState** request for each Access Point with corresponding tokens.
21. Verify the **GetAccessPointStateResponse** messages from the DUT. Verify that `Data.SimpleItem` item with `Name = "Enabled"` from Notification message has the same value

with Enabled elements from corresponding **GetAccessPointStateResponse** messages for each AccessPoint.

Test Result:**PASS –**

- DUT passes all assertions.

FAIL –

- The DUT did not send a **GetEventPropertiesResponse**
- The DUT did not send **CreatePullPointSubscriptionResponse** message.
- The DUT did not send **PullMessagesResponse** message.
- The DUT did not send valid SubscriptionReference.
- The DUT did not send a Notification message that contains a property event tns1:AccessPoint/State/Enabled at least for one Access Point.
- The DUT sent an invalid Notification message (no corresponding Source.SimpleItem or Data.SimpleItem, wrong type of Value fields, invalid AccessPointToken or State values, PropertyOperation is not equal to "Initialized").
- The DUT did not return at least one Access Point at step 3.
- The DUT did not return Topic tns1:AccessPoint/State/Enabled in **GetEventPropertiesResponse**.

Note: The Subscription Manager has to be deleted at the end of the test either by calling unsubscribe or through a timeout.

Note: ONVIF Client at step 14 will wait for Notification messages until notification for all Access Points is received or Operation Delay has expired. Notification messages for all Access Points are assumed as received, if the number of Notification messages is equal to the number of Access Points.

Note: If the DUT does not return any access point for step 3, skip steps 4-21, fail the test and go to the next test.

Note: The Subscription Manager has to be deleted at the end of the test either by calling unsubscribe or through a timeout.

Note: The **Renew** has to be used for renew subscription during test, if InitialTerminationTime expires.

Note: If DUT cannot accept the set value to Timeout or MessageLimit, ONVIF Client retries to send the PullMessage message with Timeout and MessageLimit which is contained in PullMessagesFaultResponse.

Note: If DUT cannot accept the set value to a TerminationTime, ONVIF Client retries to send the **Renew** request MinimumTime value which is contained in UnacceptableTerminationTimeFault.

Note: timeout1 will be taken from Subscription Timeout field of ONVIF Device Test Tool.

4.5.2 ACCESS CONTROL – ACCESS POINT ENABLED EVENT STATE CHANGE

Test Case ID: ACCESSCONTROL-5-1-2

Specification Coverage: tns1:AccessPoint/State/Enabled (Access Control Service Specification), EnableAccessPoint (ONVIF Access Control Service Specification), DisableAccessPoint (ONVIF Access Control Service Specification), GetAccessPointState (ONVIF Access Control Service Specification)

Feature Under Test: EnableAccessPoint, DisableAccessPoint, GetAccessPointState

WSDL Reference: event.wsdl, accesscontrol.wsdl

Test Purpose: To verify tns1:AccessPoint/State/Enabled event generation after property was changed and to verify tns1:AccessPoint/State/Enabled event format.

Pre-Requisite: Event Service was received from the DUT. Access Control Service was received from the DUT. At least one Access Point with Enable/Disable capability is configured and added to the DUT.

Test Configuration: ONVIF Client and DUT

Test Procedure:

1. Start an ONVIF Client.
2. Start the DUT.
3. Get a complete list of access points from the DUT (see [Annex A.1](#)).
4. If there is no Access Points with DisableAccessPoint equal to true, fail the test and skip other steps.
5. If Access Point with Token1 (Token1 is the first AccessPointInfo.token from the complete list of access points at step 3) has AccessPointInfo.Capabilities.DisableAccessPoint equal to false, then skip steps 6-20 and go to the step 21.

6. ONVIF Client will invoke **GetAccessPointState** request (TokenList.Token = Token1, where Token1 is the first token from the complete list of access points at step 3) to retrieve Access Point state for specified token from the DUT.
7. Verify the **GetAccessPointStateResponse** message from the DUT.
8. ONVIF Client will invoke **CreatePullPointSubscription** request with tns1:AccessPoint/State/Enabled Topic as Filter and an InitialTerminationTime of timeout1.
9. Verify that the DUT sends a **CreatePullPointSubscriptionResponse** message.
10. If Access Point with Token1 (Token1 is the first AccessPointInfo.token from the complete list of access points at step 3) has AccessPointState.Enabled equal to true, then skip steps 11-12 and go to the step 13.
11. ONVIF Client will invoke **EnableAccessPoint** request (Token = "Token1", where Token1 is the first AccessPointInfo.token from the complete list of access points at step 3) to try enabling access point.
12. Verify the **EnableAccessPointResponse** message from the DUT. Go to the step 15.
13. ONVIF Client will invoke **DisableAccessPoint** request (Token = "Token1", where Token1 is the first AccessPointInfo.token from the complete list of access points at step 3) to try disabling access point.
14. Verify the **DisableAccessPointResponse** message from the DUT.
15. ONVIF Client will invoke **PullMessages** request with a PullMessagesTimeout of 20s and a MessageLimit of 1.
16. Verify that the DUT sends a **PullMessagesResponse** that contains NotificationMessages. Repeat step 15 until Notification with PropertyOperation = "Changed" for Access Point with Token = "Token1" will be received.
17. Verify received Notification messages (correct value for UTC time, TopicExpression and wsnt:Message).
18. Verify that TopicExpression is equal to tns1:AccessPoint/State/Enabled for all received Notification messages.
19. Verify that notification contains Source.SimpleItem item with Name = "AccessPointToken" and Value = "Token1" (e.g. a complete list of access points contains Access Point with the same token).
20. Verify that notification contains Data.SimpleItem item with Name = "State" and Value with type is equal to xs:boolean and with value equal to current state of Access Point.

21. Repeat steps 5-20 for all other tokens from complete list of access points at step 3.

Test Result:

PASS –

- DUT passes all assertions.

FAIL –

- The DUT did not send **CreatePullPointSubscriptionResponse** message.
- The DUT did not send **PullMessagesResponse** message.
- The DUT did not send valid SubscriptionReference.
- The DUT did not send a Notification message that contains a property event tns1:AccessPoint/State/Enabled with valid AccessPointToken and Enabled value.
- The DUT sent an invalid Notification message (no corresponding Source.SimpleItem or Data.SimpleItem, wrong type of Value fields, invalid AccessPointToken or State values).
- The DUT did not return at least one Access Point on step 3.
- The DUT did not send valid **EnableAccessPointResponse** message.
- The DUT did not send valid **DisableAccessPointResponse** message.

Note: The Subscription Manager has to be deleted at the end of the test either by calling unsubscribe or through a timeout.

Note: All Notification messages except messages with PropertyOperation = "Changed" will be ignored.

Note: Test will be failed, if no required Notification messages are received for step 15 during a certain period of time (Operation Delay should be used in ONVIF Device Test Tool).

Note: If the DUT does not return any access point for step 3, skip steps 4-21, fail the test and go to the next test.

Note: The Subscription Manager has to be deleted at the end of the test either by calling unsubscribe or through a timeout.

Note: The **Renew** has to be used for renew subscription during a test, if InitialTerminationTime expires.

Note: If DUT cannot accept the set value to Timeout or MessageLimit, ONVIF Client retries to send the PullMessage message with Timeout and MessageLimit which is contained in PullMessagesFaultResponse.

Note: If DUT cannot accept the set value to a TerminationTime, ONVIF Client retries to send the **Renew** request MinimumTime value which is contained in UnacceptableTerminationTimeFault.

Note: timeout1 will be taken from Subscription Timeout field of ONVIF Device Test Tool.

4.6 Access granted events

4.6.1 ACCESS CONTROL – ACCESS GRANTED TO ANONYMOUS EVENT

Test Case ID: ACCESSCONTROL-6-1-1

Specification Coverage: tns1:AccessControl/AccessGranted/Anonymous (Access Control Service Specification), GetAccessPointInfoList (ONVIF Access Control Service Specification)

Feature Under Test: tns1:AccessControl/AccessGranted/Anonymous

WSDL Reference: event.wsdl, accesscontrol.wsdl

Test Purpose: To verify tns1:AccessControl/AccessGranted/Anonymous event generation and to verify tns1:AccessControl/AccessGranted/Anonymous event format.

Pre-Requisite: Event Service was received from the DUT. Access Control Service was received from the DUT. At least one Access Point with Anonymous Access capability is configured and added to the DUT.

Test Configuration: ONVIF Client and DUT

Test Procedure:

1. Start an ONVIF Client.
2. Start the DUT.
3. Get complete list of access points from the DUT (see [Annex A.1](#)).
4. If there are no Access Point with Capabilities.AnonymousAccess = “true” in complete list of access points, fail the test and skip other steps.
5. ONVIF Client will invoke **GetEventProperties** request to retrieve all events supported by the DUT.
6. Verify the **GetEventPropertiesResponse** message from the DUT.
7. Check if there is an event with Topic tns1:AccessControl/AccessGranted/Anonymous. If there is no event with such Topic skip other steps, fail the test and go to the next test.

8. Check that this event is not a Property event (MessageDescription.IsProperty = "false").
9. Check that this event contains Source.SimpleItemDescription item with Name = "AccessPointToken" and Type = "pt:ReferenceToken".
10. Check that if this event contains Data.SimpleItemDescription item with Name = "External", than it has Type = "xs:boolean".
11. ONVIF Client will invoke **CreatePullPointSubscription** request with tns1:AccessControl/AccessGranted/Anonymous Topic as Filter and an InitialTerminationTime of timeout1.
12. Verify that the DUT sends a **CreatePullPointSubscriptionResponse** message.
13. Test Operator will invoke tns1:AccessControl/AccessGranted/Anonymous event for any Access Points with Capabilities.AnonymousAccess = "true".
14. ONVIF Client will invoke **PullMessages** request with a PullMessagesTimeout of 20s and a MessageLimit of 1.
15. Verify that the DUT sends a **PullMessagesResponse** that contains one NotificationMessage. If no NotificationMessage were received repeat step 14.
16. Verify received Notification message (correct value for UTC time, TopicExpression and wsnt:Message).
17. Verify that TopicExpression is equal to tns1:AccessControl/AccessGranted/Anonymous for the Notification message.
18. Verify that the notification contains Source.SimpleItem item with Name = "AccessPointToken" and Value is equal to one of existing Access Point Tokens with Capabilities.AnonymousAccess = "true" (e.g. complete list of access points contains Access Point with the same token and this Access Point has Capabilities.AnonymousAccess = "true").
19. Verify that the notification doesn't contain Data.SimpleItem item with Name = "External", if it was not included in Topic in **GetEventPropertiesResponse** message. Verify that the notification doesn't contain Data.SimpleItem item with Name = "External" or contains Data.SimpleItem item with Name = "External" and its Value is equal to "false", if it was included in Topic in **GetEventPropertiesResponse** message.

Test Result:**PASS –**

- DUT passes all assertions.

FAIL –

- The DUT did not send a **GetEventPropertiesResponse**
- The DUT did not send **CreatePullPointSubscriptionResponse** message.
- The DUT did not send valid SubscriptionReference.
- The DUT did not send a **PullMessagesResponse** message that contains one tns1:AccessControl/AccessGranted/Anonymous event.
- The DUT sent an invalid Notification message (no corresponding Source.SimpleItem or Data.SimpleItem, wrong type of Value fields, invalid AccessPointToken value, invalid External).
- The DUT did not return at least one Access Point on step 3.
- The DUT did not return valid Topic tns1:AccessControl/AccessGranted/Anonymous in **GetEventPropertiesResponse**.

Note: The Subscription Manager has to be deleted at the end of the test either by calling unsubscribe or through a timeout.

Note: The **Renew** has to be used for renew subscription during test, if InitialTerminationTime expires.

Note: Test will be failed, if no Notification message is received for step 15 during a certain period of time (Operation Delay should be used in ONVIF Device Test Tool).

Note: If DUT cannot accept the set value to Timeout or MessageLimit, ONVIF Client retries to send the PullMessage message with Timeout and MessageLimit which is contained in PullMessagesFaultResponse.

Note: If DUT cannot accept the set value to a TerminationTime, ONVIF Client retries to send the **Renew** request MinimumTime value which is contained in UnacceptableTerminationTimeFault.

Note: timeout1 will be taken from Subscription Timeout field of ONVIF Device Test Tool.

4.6.2 ACCESS CONTROL – ACCESS GRANTED WITH CREDENTIAL EVENT

Test Case ID: ACCESSCONTROL-6-1-2

Specification Coverage: tns1:AccessControl/AccessGranted/Credential (Access Control Service Specification), GetAccessPointInfoList (ONVIF Access Control Service Specification)

Feature Under Test: tns1:AccessControl/AccessGranted/Credential

WSDL Reference: event.wsdl, accesscontrol.wsdl

Test Purpose: To verify tns1:AccessControl/AccessGranted/Credential event generation and to verify tns1:AccessControl/AccessGranted/Credential event format.

Pre-Requisite: Event Service was received from the DUT. Access Control Service was received from the DUT. At least one Access Point is configured and added to the DUT.

Test Configuration: ONVIF Client and DUT

Test Procedure:

1. Start an ONVIF Client.
2. Start the DUT.
3. Get complete list of access points from the DUT (see [Annex A.1](#)).
4. ONVIF Client will invoke **GetEventProperties** request to retrieve all events supported by the DUT.
5. Verify the **GetEventPropertiesResponse** message from the DUT.
6. Check if there is an event with Topic tns1:AccessControl/AccessGranted/Credential. If there is no event with such Topic skip other steps, fail the test and go to the next test.
7. Check that this event is not a Property event (MessageDescription.IsProperty = "false").
8. Check that this event contains Source.SimpleItemDescription item with Name = "AccessPointToken" and Type = "pt:ReferenceToken".
9. Check that this event contains Data.SimpleItemDescription item with Name = "CredentialToken" and Type = "pt:ReferenceToken".
10. Check that if this event contains Data.SimpleItemDescription item with Name = "CredentialHolderName", than it has Type = "xs:string".
11. Check that if this event contains Data.SimpleItemDescription item with Name = "External", than it has Type = "xs:boolean".
12. ONVIF Client will invoke **CreatePullPointSubscription** request with tns1:AccessControl/AccessGranted/Credential Topic as Filter and an InitialTerminationTime of timeout1.
13. Verify that the DUT sends a **CreatePullPointSubscriptionResponse** message.

14. Test Operator will invoke `tns1:AccessControl/AccessGranted/Credential` event for any Access Points.
15. ONVIF Client will invoke **PullMessages** request with a `PullMessagesTimeout` of 20s and a `MessageLimit` of 1.
16. Verify that the DUT sends a **PullMessagesResponse** that contains one `NotificationMessage`. If no `NotificationMessage` were received repeat step 15.
17. Verify received Notification message (correct value for UTC time, `TopicExpression` and `wsnt:Message`).
18. Verify that `TopicExpression` is equal to `tns1:AccessControl/AccessGranted/Credential` for the Notification message.
19. Verify that the notification contains `Source.SimpleItem` item with `Name = "AccessPointToken"` and `Value` is equal to one of existing Access Point Tokens (e.g. complete list of access points contains Access Point with the same token).
20. Verify that the notification contains `Data.SimpleItem` item with `Name = "CredentialToken"` and `Value` with type is equal to `pt:ReferenceToken`.
21. Verify that the notification which contains `Data.SimpleItem` item with `Name = "CredentialHolderName"` contains `Value` with type is equal to `xs:string`.
22. Verify that the notification doesn't contain `Data.SimpleItem` item with `Name = "External"`, if it was not included in `Topic` in **GetEventPropertiesResponse** message. Verify that the notification doesn't contain `Data.SimpleItem` item with `Name = "External"` or contains `Data.SimpleItem` item with `Name = "External"` and its `Value` is equal to "false", if it was included in `Topic` in **GetEventPropertiesResponse** message.

Test Result:**PASS –**

- DUT passes all assertions.

FAIL –

- The DUT did not send a **GetEventPropertiesResponse**
- The DUT did not send **CreatePullPointSubscriptionResponse** message.
- The DUT did not send valid `SubscriptionReference`.
- The DUT did not send a **PullMessagesResponse** message that contains one `tns1:AccessControl/AccessGranted/Credential` event.

- The DUT sent an invalid Notification message (no corresponding Source.SimpleItem or Data.SimpleItem, wrong type of Value fields, invalid AccessPointToken value, invalid CredentialToken, invalid CredentialHolderName, invalid External).
- The DUT did not return at least one Access Point on step 3.
- The DUT did not return valid Topic tns1:AccessControl/AccessGranted/Credential in **GetEventPropertiesResponse**.

Note: The Subscription Manager has to be deleted at the end of the test either by calling unsubscribe or through a timeout.

Note: The **Renew** has to be used for renew subscription during test, if InitialTerminationTime expires.

Note: Test will be failed, if no Notification message is received for step 16 during certain period of time (Operation Delay should be used in ONVIF Device Test Tool).

Note: If DUT cannot accept the set value to Timeout or MessageLimit, ONVIF Client retries to send the PullMessage message with Timeout and MessageLimit which is contained in PullMessagesFaultResponse.

Note: If DUT cannot accept the set value to a TerminationTime, ONVIF Client retries to send the **Renew** request MinimumTime value which is contained in UnacceptableTerminationTimeFault.

Note: timeout1 will be taken from Subscription Timeout field of ONVIF Device Test Tool.

4.7 Access taken events

4.7.1 ACCESS CONTROL – ACCESS TAKEN BY ANONYMOUS EVENT

Test Case ID: ACCESSCONTROL-7-1-1

Specification Coverage: tns:AccessControl/AccessGranted/Anonymous (Access Control Service Specification), AccessControl/AccessTaken/Anonymous (Access Control Service Specification), GetAccessPointInfoList (ONVIF Access Control Service Specification)

Feature Under Test: tns:AccessControl/AccessGranted/Anonymous

WSDL Reference: event.wsdl, accesscontrol.wsdl

Test Purpose: To verify tns1:AccessControl/AccessTaken/Anonymous event generation and to verify tns1:AccessControl/AccessTaken/Anonymous event format.

Pre-Requirement: Event Service was received from the DUT. Access Control Service was received from the DUT. At least one Access Point with Anonymous Access capability and Access Taken capability is configured and added to the DUT.

Test Configuration: ONVIF Client and DUT

Test Procedure:

1. Start an ONVIF Client.
2. Start the DUT.
3. Get complete list of access points from the DUT (see [Annex A.1](#)).
4. If there are no Access Point with Capabilities.AnonymousAccess = "true" and Capabilities.AccessTaken = "true" in complete list of access points, fail the test and skip other steps.
5. ONVIF Client will invoke **GetEventProperties** request to retrieve all events supported by the DUT.
6. Verify the **GetEventPropertiesResponse** message from the DUT.
7. Check if there is an event with Topic tns1:AccessControl/AccessTaken/Anonymous. If there is no event with such Topic skip other steps, fail the test and go to the next test.
8. Check that this event is not a Property event (MessageDescription.IsProperty = "false").
9. Check that this event contains Source.SimpleItemDescription item with Name = "AccessPointToken" and Type = "pt:ReferenceToken".
10. ONVIF Client will invoke **CreatePullPointSubscription** request with tns1:AccessControl/AccessGranted/Anonymous Topic and tns1:AccessControl/AccessTaken/Anonymous Topic as Filter and an InitialTerminationTime of timeout1.
11. Verify that the DUT sends a **CreatePullPointSubscriptionResponse** message.
12. Test Operator will invoke tns1:AccessControl/AccessGranted/Anonymous event for any Access Points with Capabilities.AnonymousAccess = "true" and Capabilities.AccessTaken = "true".
13. ONVIF Client will invoke **PullMessages** request with a PullMessagesTimeout of 20s and a MessageLimit of 1.
14. Verify that the DUT sends a **PullMessagesResponse** that contains one NotificationMessage. If no NotificationMessage were received repeat step [13](#).

15. Verify received Notification message (correct value for UTC time, TopicExpression and wsnt:Message).
16. Verify that TopicExpression is equal to tns1:AccessControl/AccessGranted/Anonymous for the Notification message.
17. Test Operator will invoke tns1:AccessControl/AccessTaken/Anonymous event for the same Access Point.
18. ONVIF Client will invoke **PullMessages** request with a PullMessagesTimeout of 20s and a MessageLimit of 1.
19. Verify that the DUT sends a **PullMessagesResponse** that contains one NotificationMessage. If no NotificationMessage were received repeat step 18.
20. Verify that TopicExpression is equal to tns1:AccessControl/AccessTaken/Anonymous for the Notification message.
21. Verify that the notification contains Source.SimpleItem item with Name = "AccessPointToken" and Value is equal to AccessPointToken from tns1:AccessControl/AccessGranted/Anonymous notification and there is Access Point Tokens with Capabilities.AnonymousAccess = "true" and Capabilities.AccessTaken = "true" in the complete list of access points (e.g. complete list of access points contains Access Point with the same token and this Access Point has Capabilities.AnonymousAccess = "true" and Capabilities.AccessTaken = "true").

Test Result:

PASS –

- DUT passes all assertions.

FAIL –

- The DUT did not send a **GetEventPropertiesResponse**
- The DUT did not send **CreatePullPointSubscriptionResponse** message.
- The DUT did not send valid SubscriptionReference.
- The DUT did not send a **PullMessagesResponse** message that contains one tns1:AccessControl/AccessGranted/Anonymous event on step 14.
- The DUT did not send a **PullMessagesResponse** message that contains one tns1:AccessControl/AccessTaken/Anonymous event on step 19.

- The DUT sent an invalid Notification message (no corresponding Source.SimpleItem or Data.SimpleItem, wrong type of Value fields, invalid AccessPointToken value) on step 19.
- The DUT did not return at least one Access Point on step 3.
- The DUT did not return valid Topic tns1:AccessControl/AccessTaken/Anonymous in **GetEventPropertiesResponse**.

Note: The Subscription Manager has to be deleted at the end of the test either by calling unsubscribe or through a timeout.

Note: The **Renew** has to be used for renew subscription during test, if InitialTerminationTime expires.

Note: Test will be failed, if no Notification message is received for steps 14 and 19 during a certain period of time (Operation Delay should be used in ONVIF Device Test Tool).

Note: If DUT cannot accept the set value to Timeout or MessageLimit, ONVIF Client retries to send the PullMessage message with Timeout and MessageLimit which is contained in PullMessagesFaultResponse.

Note: If DUT cannot accept the set value to a TerminationTime, ONVIF Client retries to send the **Renew** request MinimumTime value which is contained in UnacceptableTerminationTimeFault.

Note: timeout1 will be taken from Subscription Timeout field of ONVIF Device Test Tool.

4.7.2 ACCESS CONTROL – ACCESS TAKEN WITH CREDENTIAL EVENT

Test Case ID: ACCESSCONTROL-7-1-2

Specification Coverage: tns:AccessControl/AccessGranted/Credential (Access Control Service Specification), tns1:AccessControl/AccessTaken/Credential (Access Control Service Specification), GetAccessPointInfoList (ONVIF Access Control Service Specification)

Feature Under Test: tns:AccessControl/AccessGranted/Credential

WSDL Reference: event.wsdl, accesscontrol.wsdl

Test Purpose: To verify tns1:AccessControl/AccessTaken/Credential event generation and to verify tns1:AccessControl/AccessTaken/Credential event format.

Pre-Requisite: Event Service was received from the DUT. Access Control Service was received from the DUT. At least one Access Point with Access Taken capability is configured and added to the DUT.

Test Configuration: ONVIF Client and DUT**Test Procedure:**

1. Start an ONVIF Client.
2. Start the DUT.
3. Get complete list of access points from the DUT (see [Annex A.1](#)).
4. If there are no Access Points with Capabilities.AccessTaken = "true" in complete list of access points, fail the test and skip other steps.
5. ONVIF Client will invoke **GetEventProperties** request to retrieve all events supported by the DUT.
6. Verify the **GetEventPropertiesResponse** message from the DUT.
7. Check if there is an event with Topic tns1:AccessControl/AccessTaken/Credential. If there is no event with such Topic skip other steps, fail the test and go to the next test.
8. Check that this event is not a Property event (MessageDescription.IsProperty = "false").
9. Check that this event contains Source.SimpleItemDescription item with Name = "AccessPointToken" and Type = "pt:ReferenceToken".
10. Check that this event contains Data.SimpleItemDescription item with Name = "CredentialToken" and Type = "pt:ReferenceToken".
11. Check that if this event contains Data.SimpleItemDescription item with Name = "CredentialHolderName", than it has Type = "xs:string".
12. ONVIF Client will invoke **CreatePullPointSubscription** request with tns1:AccessControl/AccessGranted/Credential Topic and tns1:AccessControl/AccessTaken/Credential Topic as Filter and an InitialTerminationTime of timeout1.
13. Verify that the DUT sends a **CreatePullPointSubscriptionResponse** message.
14. Test Operator will invoke tns1:AccessControl/AccessGranted/Credential event for any Access Points with Capabilities.AccessTaken = "true".
15. ONVIF Client will invoke **PullMessages** request with a PullMessagesTimeout of 20s and a MessageLimit of 1.
16. Verify that the DUT sends a **PullMessagesResponse** that contains one NotificationMessage. If no NotificationMessage were received repeat step [15](#).

17. Verify received Notification message (correct value for UTC time, TopicExpression and wsnt:Message).
18. Verify that TopicExpression is equal to tns1:AccessControl/AccessGranted/Credential for the Notification message.
19. Test Operator will invoke tns1:AccessControl/AccessTaken/Credential event for the same Access Point.
20. ONVIF Client will invoke **PullMessages** request with a PullMessagesTimeout of 20s and a MessageLimit of 1.
21. Verify that the DUT sends a **PullMessagesResponse** that contains one NotificationMessage. If no NotificationMessage were received repeat step 20.
22. Verify received Notification message (correct value for UTC time, TopicExpression and wsnt:Message).
23. Verify that TopicExpression is equal to tns1:AccessControl/AccessTaken/Credential for the Notification message.
24. Verify that the notification contains Source.SimpleItem item with Name = "AccessPointToken" and Value is equal to AccessPointToken from tns1:AccessControl/AccessGranted/Credential notification and there is Access Point Tokens with Capabilities.AccessTaken = "true" in the complete list of access points (e.g. complete list of access points contains Access Point with the same token and this Access Point has Capabilities.AccessTaken = "true").
25. Verify that the notification contains Data.SimpleItem item with Name = "CredentialToken" and Value with type is equal to pt:ReferenceToken. Verify that this value is equal to the same Data.SimpleItem from tns1:AccessControl/AccessGranted/Credential notification.
26. Verify that the notification which contains Data.SimpleItem item with Name = "CredentialHolderName" contains Value with type is equal to xs:string. Verify that this value is equal to the same Data.SimpleItem from tns1:AccessControl/AccessGranted/Credential notification.

Test Result:**PASS –**

- DUT passes all assertions.

FAIL –

- The DUT did not send a **GetEventPropertiesResponse**

- The DUT did not send **CreatePullPointSubscriptionResponse** message.
- The DUT did not send valid SubscriptionReference.
- The DUT did not send a **PullMessagesResponse** message that contains one tns1:AccessControl/AccessGranted/Credential event on step 16.
- The DUT did not send a **PullMessagesResponse** message that contains one tns1:AccessControl/AccessTaken/Credential event on step 21.
- The DUT sent an invalid Notification message (no corresponding Source.SimpleItem or Data.SimpleItem, wrong type of Value fields, invalid AccessPointToken value, invalid CredentialToken value, and invalid CredentialHolderName value) on step 21.
- The DUT did not return at least one Access Point on step 3.
- The DUT did not return valid Topic tns1:AccessControl/AccessTaken/Credential in **GetEventPropertiesResponse**.

Note: The Subscription Manager has to be deleted at the end of the test either by calling unsubscribe or through a timeout.

Note: The **Renew** has to be used for renew subscription during test, if InitialTerminationTime expires.

Note: Test will be failed, if no Notification message is received for step 16 and 19 during a certain period of time (Operation Delay should be used in ONVIF Device Test Tool).

Note: If DUT cannot accept the set value to Timeout or MessageLimit, ONVIF Client retries to send the PullMessage message with Timeout and MessageLimit which is contained in PullMessagesFaultResponse.

Note: If DUT cannot accept the set value to a TerminationTime, ONVIF Client retries to send the **Renew** request MinimumTime value which is contained in UnacceptableTerminationTimeFault.

Note: timeout1 will be taken from Subscription Timeout field of ONVIF Device Test Tool.

4.8 Access not taken events

4.8.1 ACCESS CONTROL – ACCESS NOT TAKEN BY ANONYMOUS EVENT

Test Case ID: ACCESSCONTROL-8-1-1

Specification Coverage: tns:AccessControl/AccessGranted/Anonymous (Access Control Service Specification), AccessControl/AccessNotTaken/Anonymous (Access Control Service Specification), GetAccessPointInfoList (ONVIF Access Control Service Specification)

Feature Under Test: AccessControl/AccessNotTaken/Anonymous

WSDL Reference: event.wsdl, accesscontrol.wsdl

Test Purpose: To verify tns1:AccessControl/AccessNotTaken/Anonymous event generation and to verify tns1:AccessControl/AccessNotTaken/Anonymous event format.

Pre-Requisite: Event Service was received from the DUT. Access Control Service was received from the DUT. At least one Access Point with Anonymous Access capability and Access Taken capability is configured and added to the DUT.

Test Configuration: ONVIF Client and DUT

Test Procedure:

1. Start an ONVIF Client.
2. Start the DUT.
3. Get complete list of access points from the DUT (see [Annex A.1](#)).
4. If there are no Access Points with Capabilities.AnonymousAccess = "true" and Capabilities.AccessTaken = "true" in complete list of access points, fail the test and skip other steps.
5. ONVIF Client will invoke **GetEventProperties** request to retrieve all events supported by the DUT.
6. Verify the **GetEventPropertiesResponse** message from the DUT.
7. Check if there is an event with Topic tns1:AccessControl/AccessNotTaken/Anonymous. If there is no event with such Topic skip other steps, fail the test and go to the next test.
8. Check that this event is not a Property event (MessageDescription.IsProperty = "false").
9. Check that this event contains Source.SimpleItemDescription item with Name = "AccessPointToken" and Type = "pt:ReferenceToken".
10. ONVIF Client will invoke **CreatePullPointSubscription** request with tns1:AccessControl/AccessGranted/Anonymous Topic and tns1:AccessControl/AccessNotTaken/Anonymous Topic as Filter and an InitialTerminationTime of timeout1.
11. Verify that the DUT sends a **CreatePullPointSubscriptionResponse** message.

12. Test Operator will invoke `tns1:AccessControl/AccessGranted/Anonymous` event for any Access Points with `Capabilities.AnonymousAccess = "true"` and `Capabilities.AccessTaken = "true"`.
13. ONVIF Client will invoke **PullMessages** request with a `PullMessagesTimeout` of 20s and a `MessageLimit` of 1.
14. Verify that the DUT sends a **PullMessagesResponse** that contains one `NotificationMessage`. If no `NotificationMessage` were received repeat step 13.
15. Verify received `NotificationMessage` (correct value for UTC time, `TopicExpression` and `wsnt:Message`).
16. Verify that `TopicExpression` is equal to `tns1:AccessControl/AccessGranted/Anonymous` for the `NotificationMessage`.
17. Test Operator will invoke `tns1:AccessControl/AccessNotTaken/Anonymous` event for the same Access Point.
18. ONVIF Client will invoke **PullMessages** request with a `PullMessagesTimeout` of 20s and a `MessageLimit` of 1.
19. Verify that the DUT sends a **PullMessagesResponse** that contains one `NotificationMessage`. If no `NotificationMessage` were received repeat step 18.
20. Verify that `TopicExpression` is equal to `tns1:AccessControl/AccessNotTaken/Anonymous` for the `NotificationMessage`.
21. Verify that the notification contains `Source.SimpleItem` item with `Name = "AccessPointToken"` and `Value` is equal to `AccessPointToken` from `tns1:AccessControl/AccessGranted/Anonymous` notification and there is Access Point Tokens with `Capabilities.AnonymousAccess = "true"` and `Capabilities.AccessTaken = "true"` in the complete list of access points (e.g. complete list of access points contains Access Point with the same token and this Access Point has `Capabilities.AnonymousAccess = "true"` and `Capabilities.AccessTaken = "true"`).

Test Result:**PASS –**

- DUT passes all assertions.

FAIL –

- The DUT did not send a **GetEventPropertiesResponse**

- The DUT did not send **CreatePullPointSubscriptionResponse** message.
- The DUT did not send valid SubscriptionReference.
- The DUT did not send a **PullMessagesResponse** message that contains one tns1:AccessControl/AccessGranted/Anonymous event on step 14.
- The DUT did not send a **PullMessagesResponse** message that contains one tns1:AccessControl/AccessNotTaken/Anonymous event on step 19.
- The DUT sent an invalid Notification message (no corresponding Source.SimpleItem or Data.SimpleItem, wrong type of Value fields, invalid AccessPointToken value) on step 19.
- The DUT did not return at least one Access Point on step 3.
- The DUT did not return valid Topic tns1:AccessControl/AccessNotTaken/Anonymous in **GetEventPropertiesResponse**.

Note: The Subscription Manager has to be deleted at the end of the test either by calling unsubscribe or through a timeout.

Note: The **Renew** has to be used for renew subscription during test, if InitialTerminationTime expires.

Note: Test will be failed, if no Notification message is received for steps 14 and 19 during a certain period of time (Operation Delay should be used in ONVIF Device Test Tool).

Note: If DUT cannot accept the set value to Timeout or MessageLimit, ONVIF Client retries to send the PullMessage message with Timeout and MessageLimit which is contained in PullMessagesFaultResponse.

Note: If DUT cannot accept the set value to a TerminationTime, ONVIF Client retries to send the **Renew** request MinimumTime value which is contained in UnacceptableTerminationTimeFault.

Note: timeout1 will be taken from Subscription Timeout field of ONVIF Device Test Tool.

4.8.2 ACCESS CONTROL – ACCESS NOT TAKEN WITH CREDENTIAL EVENT

Test Case ID: ACCESSCONTROL-8-1-2

Specification Coverage: tns:AccessControl/AccessGranted/Credential (Access Control Service Specification), tns1:AccessControl/AccessNotTaken/Credential (Access Control Service Specification), GetAccessPointInfoList (ONVIF Access Control Service Specification)

Feature Under Test: tns1:AccessControl/AccessNotTaken/Credential

WSDL Reference: event.wsdl, accesscontrol.wsdl

Test Purpose: To verify tns1:AccessControl/AccessNotTaken/Credential event generation and to verify tns1:AccessControl/AccessNotTaken/Credential event format.

Pre-Requirement: Event Service was received from the DUT. Access Control Service was received from the DUT. At least one Access Point with Access Taken capability is configured and added to the DUT.

Test Configuration: ONVIF Client and DUT

Test Procedure:

1. Start an ONVIF Client.
2. Start the DUT.
3. Get complete list of access points from the DUT (see [Annex A.1](#)).
4. If there are no Access Point with Capabilities.AccessTaken = "true" in complete list of access points, fail the test and skip other steps.
5. ONVIF Client will invoke **GetEventProperties** request to retrieve all events supported by the DUT.
6. Verify the **GetEventPropertiesResponse** message from the DUT.
7. Check if there is an event with Topic tns1:AccessControl/AccessNotTaken/Credential. If there is no event with such Topic skip other steps, fail the test and go to the next test.
8. Check that this event is not a Property event (MessageDescription.IsProperty = "false").
9. Check that this event contains Source.SimpleItemDescription item with Name = "AccessPointToken" and Type = "pt:ReferenceToken".
10. Check that this event contains Data.SimpleItemDescription item with Name = "CredentialToken" and Type = "pt:ReferenceToken".
11. Check that if this event contains Data.SimpleItemDescription item with Name = "CredentialHolderName", than it has Type = "xs:string".
12. ONVIF Client will invoke **CreatePullPointSubscription** request with tns1:AccessControl/AccessGranted/Credential Topic and tns1:AccessControl/AccessNotTaken/Credential Topic as Filter and an InitialTerminationTime of timeout1.
13. Verify that the DUT sends a **CreatePullPointSubscriptionResponse** message.

14. Test Operator will invoke `tns1:AccessControl/AccessGranted/Credential` event for any Access Points with `Capabilities.AccessTaken = "true"`.
15. ONVIF Client will invoke **PullMessages** request with a `PullMessagesTimeout` of 20s and a `MessageLimit` of 1.
16. Verify that the DUT sends a **PullMessagesResponse** that contains one `NotificationMessage`. If no `NotificationMessage` were received repeat step 15.
17. Verify received Notification message (correct value for UTC time, `TopicExpression` and `wsnt:Message`).
18. Verify that `TopicExpression` is equal to `tns1:AccessControl/AccessGranted/Credential` for the Notification message.
19. Test Operator will invoke `tns1:AccessControl/AccessNotTaken/Credential` event for the same Access Point.
20. ONVIF Client will invoke **PullMessages** request with a `PullMessagesTimeout` of 20s and a `MessageLimit` of 1.
21. Verify that the DUT sends a **PullMessagesResponse** that contains one `NotificationMessage`. If no `NotificationMessage` were received repeat step 20.
22. Verify received Notification message (correct value for UTC time, `TopicExpression` and `wsnt:Message`).
23. Verify that `TopicExpression` is equal to `tns1:AccessControl/AccessNotTaken/Credential` for the Notification message.
24. Verify that the notification contains `Source.SimpleItem` item with `Name = "AccessPointToken"` and `Value` is equal to `AccessPointToken` from `tns1:AccessControl/AccessGranted/Credential` notification and there is Access Point Tokens with `Capabilities.AccessTaken = "true"` in the complete list of access points (e.g. complete list of access points contains Access Point with the same token and this Access Point has `Capabilities.AccessTaken = "true"`).
25. Verify that the notification contains `Data.SimpleItem` item with `Name = "CredentialToken"` and `Value` with type is equal to `pt:ReferenceToken`. Verify that this value is equal to the same `Data.SimpleItem` from `tns1:AccessControl/AccessGranted/Credential` notification.
26. Verify that the notification which contains `Data.SimpleItem` item with `Name = "CredentialHolderName"` contains `Value` with type is equal to `xs:string`. Verify that this value is equal to the same `Data.SimpleItem` from `tns1:AccessControl/AccessGranted/Credential` notification.

Test Result:**PASS –**

- DUT passes all assertions.

FAIL –

- The DUT did not send a **GetEventPropertiesResponse**
- The DUT did not send **CreatePullPointSubscriptionResponse** message.
- The DUT did not send valid SubscriptionReference.
- The DUT did not send a **PullMessagesResponse** message that contains one tns1:AccessControl/AccessGranted/Credential event on step 16.
- The DUT did not send a **PullMessagesResponse** message that contains one tns1:AccessControl/AccessNotTaken/Credential event on step 21.
- The DUT sent an invalid Notification message (no corresponding Source.SimpleItem or Data.SimpleItem, wrong type of Value fields, invalid AccessPointToken value, invalid CredentialToken value, and invalid CredentialHolderName value) on step 21.
- The DUT did not return at least one Access Point on step 3.
- The DUT did not return valid Topic tns1:AccessControl/AccessNotTaken/Credential in **GetEventPropertiesResponse**.

Note: The Subscription Manager has to be deleted at the end of the test either by calling unsubscribe or through a timeout.

Note: The **Renew** has to be used for renew subscription during test, if InitialTerminationTime will expire.

Note: Test will be failed, if no Notification message is received for step 16 and 19 during a certain period of time (Operation Delay should be used in ONVIF Device Test Tool).

Note: If DUT cannot accept the set value to Timeout or MessageLimit, ONVIF Client retries to send the PullMessage message with Timeout and MessageLimit which is contained in PullMessagesFaultResponse.

Note: If DUT cannot accept the set value to a TerminationTime, ONVIF Client retries to send the **Renew** request MinimumTime value which is contained in UnacceptableTerminationTimeFault.

Note: timeout1 will be taken from Subscription Timeout field of ONVIF Device Test Tool.

4.9 Access denied events

4.9.1 ACCESS CONTROL – ACCESS DENIED TO ANONYMOUS EVENT

Test Case ID: ACCESSCONTROL-9-1-1

Specification Coverage: tns1:AccessControl/Denied/Anonymous (Access Control Service Specification), GetAccessPointInfoList (ONVIF Access Control Service Specification)

Feature Under Test: tns1:AccessControl/Denied/Anonymous

WSDL Reference: event.wsdl, accesscontrol.wsdl

Test Purpose: To verify tns1:AccessControl/Denied/Anonymous event generation and to verify tns1:AccessControl/Denied/Anonymous event format.

Pre-Requisite: Event Service was received from the DUT. Access Control Service was received from the DUT. At least one Access Point with Anonymous Access capability is configured and added to the DUT.

Test Configuration: ONVIF Client and DUT

Test Procedure:

1. Start an ONVIF Client.
2. Start the DUT.
3. Get complete list of access points from the DUT (see [Annex A.1](#)).
4. If there are no Access Points with Capabilities.AnonymousAccess = "true" in complete list of access points, fail the test and skip other steps.
5. ONVIF Client will invoke **GetEventProperties** request to retrieve all events supported by the DUT.
6. Verify the **GetEventPropertiesResponse** message from the DUT.
7. Check if there is an event with Topic tns1:AccessControl/Denied/Anonymous. If there is no event with such Topic skip other steps, fail the test and go to the next test.
8. Check that this event is not a Property event (MessageDescription.IsProperty = "false").
9. Check that this event contains Source.SimpleItemDescription item with Name = "AccessPointToken" and Type = "pt:ReferenceToken".

10. Check that if this event contains Data.SimpleItemDescription item with Name = "External", than it has Type = "xs:boolean".
11. Check that this event contains Data.SimpleItemDescription item with Name = "Reason" and Type = "xs:string".
12. ONVIF Client will invoke **CreatePullPointSubscription** request with tns1:AccessControl/Denied/Anonymous Topic as Filter and an InitialTerminationTime of timeout1.
13. Verify that the DUT sends a **CreatePullPointSubscriptionResponse** message.
14. Test Operator will invoke tns1:AccessControl/Denied/Anonymous event for any Access Points with Capabilities.AnonymousAccess = "true".
15. ONVIF Client will invoke **PullMessages** request with a PullMessagesTimeout of 20s and a MessageLimit of 1.
16. Verify that the DUT sends a **PullMessagesResponse** that contains one NotificationMessage. If no NotificationMessage were received repeat step 15.
17. Verify received Notification message (correct value for UTC time, TopicExpression and wsnt:Message).
18. Verify that TopicExpression is equal to tns1:AccessControl/Denied/Anonymous for the Notification message.
19. Verify that the notification contains Source.SimpleItem item with Name = "AccessPointToken" and Value is equal to one of existing Access Point Tokens with Capabilities.AnonymousAccess = "true" (e.g. complete list of access points contains Access Point with the same token and this Access Point has Capabilities.AnonymousAccess = "true").
20. Verify that the notification doesn't contain Data.SimpleItem item with Name = "External", if it was not included in Topic in **GetEventPropertiesResponse** message. Verify that the notification doesn't contain Data.SimpleItem item with Name = "External" or contains Data.SimpleItem item with Name = "External" and its Value is equal to "false", if it was included in Topic in **GetEventPropertiesResponse** message.
21. Verify that the notification contains Data.SimpleItem item with Name = "Reason" contains Value with type is equal to xs:string. Check that Reason value is one of the following strings: "CredentialNotEnabled", "CredentialNotActive", "CredentialExpired", "InvalidPIN", "NotPermittedAtThisTime", "Unauthorized", "Other".

Test Result:**PASS –**

- DUT passes all assertions.

FAIL –

- The DUT did not send a **GetEventPropertiesResponse**
- The DUT did not send **CreatePullPointSubscriptionResponse** message.
- The DUT did not send valid SubscriptionReference.
- The DUT did not send a **PullMessagesResponse** message that contains one tns1:AccessControl/Denied/Anonymous event.
- The DUT sent an invalid Notification message (no corresponding Source.SimpleItem or Data.SimpleItem, wrong type of Value fields, invalid AccessPointToken value, invalid External, invalid Reason).
- The DUT did not return at least one Access Point on step 3.
- The DUT did not return valid Topic tns1:AccessControl/Denied/Anonymous in **GetEventPropertiesResponse**.

Note: The Subscription Manager has to be deleted at the end of the test either by calling unsubscribe or through a timeout.

Note: The **Renew** has to be used for renew subscription during test, if InitialTerminationTime expires.

Note: Test will be failed, if no Notification message will be received for step 16 during certain period of time (Operation Delay should be used in ONVIF Device Test Tool).

Note: If DUT cannot accept the set value to Timeout or MessageLimit, ONVIF Client retries to send the PullMessage message with Timeout and MessageLimit which is contained in PullMessagesFaultResponse.

Note: If DUT cannot accept the set value to a TerminationTime, ONVIF Client retries to send the **Renew** request MinimumTime value which is contained in UnacceptableTerminationTimeFault.

Note: timeout1 will be taken from Subscription Timeout field of ONVIF Device Test Tool.

4.9.2 ACCESS CONTROL – ACCESS DENIED WITH CREDENTIAL EVENT

Test Case ID: ACCESSCONTROL-9-1-2

Specification Coverage: tns1:AccessControl/Denied/Credential (Access Control Service Specification), GetAccessPointInfoList (ONVIF Access Control Service Specification)

Feature Under Test: tns1:AccessControl/Denied/Credential

WSDL Reference: event.wsdl, accesscontrol.wsdl

Test Purpose: To verify tns1:AccessControl/Denied/Credential generation and to verify tns1:AccessControl/Denied/Credential event format.

Pre-Requisite: Event Service was received from the DUT. Access Control Service was received from the DUT. At least one Access Point is configured and added to the DUT.

Test Configuration: ONVIF Client and DUT

Test Procedure:

1. Start an ONVIF Client.
2. Start the DUT.
3. Get complete list of access points from the DUT (see [Annex A.1](#)).
4. ONVIF Client will invoke **GetEventProperties** request to retrieve all events supported by the DUT.
5. Verify the **GetEventPropertiesResponse** message from the DUT.
6. Check if there is an event with Topic tns1:AccessControl/Denied/Credential. If there is no event with such Topic skip other steps, fail the test and go to the next test.
7. Check that this event is not a Property event (MessageDescription.IsProperty = "false").
8. Check that this event contains Source.SimpleItemDescription item with Name = "AccessPointToken" and Type = "pt:ReferenceToken".
9. Check that this event contains Data.SimpleItemDescription item with Name = "CredentialToken" and Type = "pt:ReferenceToken".
10. Check that if this event contains Data.SimpleItemDescription item with Name = "CredentialHolderName", than it has Type = "xs:string".
11. Check that if this event contains Data.SimpleItemDescription item with Name = "External", than it has Type = "xs:boolean".
12. Check that this event contains Data.SimpleItemDescription item with Name = "Reason" and Type = "xs:string".

13. ONVIF Client will invoke **CreatePullPointSubscription** request with tns1:AccessControl/Denied/Credential Topic as Filter and an InitialTerminationTime of timeout1.
14. Verify that the DUT sends a **CreatePullPointSubscriptionResponse** message.
15. Test Operator will invoke tns1:AccessControl/Denied/Credential event for any Access Points.
16. ONVIF Client will invoke **PullMessages** request with a PullMessagesTimeout of 20s and a MessageLimit of 1.
17. Verify that the DUT sends a **PullMessagesResponse** that contains one NotificationMessage. If no NotificationMessage were received repeat step 16.
18. Verify received Notification message (correct value for UTC time, TopicExpression and wsnt:Message).
19. Verify that TopicExpression is equal to tns1:AccessControl/Denied/Credential for the Notification message.
20. Verify that the notification contains Source.SimpleItem item with Name = "AccessPointToken" and Value is equal to one of existing Access Point Tokens (e.g. complete list of access points contains Access Point with the same token).
21. Verify that the notification contains Data.SimpleItem item with Name = "CredentialToken" and Value with type is equal to pt:ReferenceToken.
22. Verify that the notification which contains Data.SimpleItem item with Name = "CredentialHolderName" contains Value with type is equal to xs:string.
23. Verify that the notification doesn't contain Data.SimpleItem item with Name = "External", if it was not included in Topic in **GetEventPropertiesResponse** message. Verify that the notification doesn't contain Data.SimpleItem item with Name = "External" or contains Data.SimpleItem item with Name = "External" and its Value is equal to "false", if it was included in Topic in **GetEventPropertiesResponse** message.
24. Verify that the notification contains Data.SimpleItem item with Name = "Reason" contains Value with type is equal to xs:string. Check that Reason value is one of the following strings: "CredentialNotEnabled", "CredentialNotActive", "CredentialExpired", "InvalidPIN", "NotPermittedAtThisTime", "Unauthorized", "Other".

Test Result:**PASS –**

- DUT passes all assertions.

FAIL –

- The DUT did not send a **GetEventPropertiesResponse**
- The DUT did not send **CreatePullPointSubscriptionResponse** message.
- The DUT did not send valid SubscriptionReference.
- The DUT did not send a **PullMessagesResponse** message that contains one tns1:AccessControl/Denied/Credential event.
- The DUT sent an invalid Notification message (no corresponding Source.SimpleItem or Data.SimpleItem, wrong type of Value fields, invalid AccessPointToken value, invalid CredentialToken, invalid CredentialHolderName, invalid External, invalid Reason).
- The DUT did not return at least one Access Point on step 3.
- The DUT did not return valid Topic tns1:AccessControl/Denied/Credential in **GetEventPropertiesResponse**.

Note: The Subscription Manager has to be deleted at the end of the test either by calling unsubscribe or through a timeout.

Note: The **Renew** has to be used for renew subscription during test, if InitialTerminationTime expires.

Note: Test will be failed, if no Notification message is received for step 17 during a certain period of time (Operation Delay should be used in ONVIF Device Test Tool).

Note: If DUT cannot accept the set value to Timeout or MessageLimit, ONVIF Client retries to send the PullMessage message with Timeout and MessageLimit which is contained in PullMessagesFaultResponse.

Note: If DUT cannot accept the set value to a TerminationTime, ONVIF Client retries to send the **Renew** request MinimumTime value which is contained in UnacceptableTerminationTimeFault.

Note: timeout1 will be taken from Subscription Timeout field of ONVIF Device Test Tool.

4.9.3 ACCESS CONTROL – ACCESS DENIED WITH CREDENTIAL EVENT (CREDENTIAL NOT FOUND – CARD)

Test Case ID: ACCESSCONTROL-9-1-3

Specification Coverage: tns1:AccessControl/Denied/CredentialNotFound/Card (Access Control Service Specification), GetAccessPointInfoList (ONVIF Access Control Service Specification)

Feature Under Test: tns1:AccessControl/Denied/CredentialNotFound/Card

WSDL Reference: event.wsdl, accesscontrol.wsdl

Test Purpose: To verify tns1:AccessControl/Denied/CredentialNotFound/Card generation and to verify tns1:AccessControl/Denied/CredentialNotFound/Card format.

Pre-Requisite: Event Service was received from the DUT. Access Control Service was received from the DUT. At least one Access Point with tns1:AccessControl/Denied/CredentialNotFound/Card event capability is configured and added to the DUT.

Test Configuration: ONVIF Client and DUT

Test Procedure:

1. Start an ONVIF Client.
2. Start the DUT.
3. Get complete list of access points from the DUT (see [Annex A.1](#)).
4. ONVIF Client will invoke **GetEventProperties** request to retrieve all events supported by the DUT.
5. Verify the **GetEventPropertiesResponse** message from the DUT.
6. Check if there is an event with Topic tns1:AccessControl/Denied/CredentialNotFound/Card. If there is no event with such Topic fail the test and skip other steps.
7. Check that this event is not a Property event (MessageDescription.IsProperty = "false").
8. Check that this event contains Source.SimpleItemDescription item with Name = "AccessPointToken" and Type = "pt:ReferenceToken".
9. Check that this event contains Data.SimpleItemDescription item with Name = "Card" and Type = "xs:string".
10. ONVIF Client will invoke **CreatePullPointSubscription** request with tns1:AccessControl/Denied/CredentialNotFound/Card Topic as Filter and an InitialTerminationTime of timeout1.
11. Verify that the DUT sends a **CreatePullPointSubscriptionResponse** message.
12. Test Operator will invoke tns1:AccessControl/Denied/CredentialNotFound/Card event for any Access Points.
13. ONVIF Client will invoke **PullMessages** request with a PullMessagesTimeout of 20s and a MessageLimit of 1.

14. Verify that the DUT sends a **PullMessagesResponse** that contains one NotificationMessage. If no NotificationMessage were received repeat step 13.
15. Verify received Notification message (correct value for UTC time, TopicExpression and wsnt:Message).
16. Verify that TopicExpression is equal to tns1:AccessControl/Denied/CredentialNotFound/Card for the Notification message.
17. Verify that the notification contains Source.SimpleItem item with Name = "AccessPointToken" and Value is equal to one of existing Access Point Tokens (e.g. complete list of access points contains Access Point with the same token).
18. Verify that the notification contains Data.SimpleItem item with Name = "Card" and Value with type is equal to xs:string.

Test Result:**PASS –**

- DUT passes all assertions.

FAIL –

- The DUT did not send a **GetEventPropertiesResponse**
- The DUT did not send **CreatePullPointSubscriptionResponse** message.
- The DUT did not send valid SubscriptionReference.
- The DUT did not send a **PullMessagesResponse** message that contains one tns1:AccessControl/Denied/CredentialNotFound/Card event.
- The DUT sent an invalid Notification message (no corresponding Source.SimpleItem or Data.SimpleItem, wrong type of Value fields, invalid AccessPointToken value, invalid Card).
- The DUT did not return at least one Access Point on step 3.
- The DUT did not return valid Topic tns1:AccessControl/Denied/CredentialNotFound/Card in **GetEventPropertiesResponse**.

Note: The Subscription Manager has to be deleted at the end of the test either by calling unsubscribe or through a timeout.

Note: The **Renew** has to be used for renew subscription during test, if InitialTerminationTime expires.

Note: Test will be failed, if no Notification message is received for step 14 during a certain period of time (Operation Delay should be used in ONVIF Device Test Tool).

Note: If DUT cannot accept the set value to Timeout or MessageLimit, ONVIF Client retries to send the PullMessage message with Timeout and MessageLimit which is contained in PullMessagesFaultResponse.

Note: If DUT cannot accept the set value to a TerminationTime, ONVIF Client retries to send the **Renew** request MinimumTime value which is contained in UnacceptableTerminationTimeFault.

Note: timeout1 will be taken from Subscription Timeout field of ONVIF Device Test Tool.

4.10 Duress events

4.10.1 ACCESS CONTROL – DURESS

Test Case ID: ACCESSCONTROL-10-1-2

Specification Coverage: tns:AccessControl/Duress (Access Control Service Specification), GetAccessPointInfoList (ONVIF Access Control Service Specification)

Feature Under Test: tns:AccessControl/Duress

WSDL Reference: event.wsdl, accesscontrol.wsdl

Test Purpose: To verify tns1:AccessControl/Duress event generation and to verify tns1:AccessControl/Duress event format.

Pre-Requisite: Event Service was received from the DUT. Access Control Service was received from the DUT. At least one Access Point with Duress capability is configured and added to the DUT.

Test Configuration: ONVIF Client and DUT

Test Procedure:

1. Start an ONVIF Client.
2. Start the DUT.
3. Get a complete list of access points from the DUT (see [Annex A.1](#)).
4. If there is no Access Point with Capabilities.Duress = "true" on complete list of access points, fail the test and skip other steps.
5. ONVIF Client will invoke **GetEventProperties** request to retrieve all events supported by the DUT.

6. Verify the **GetEventPropertiesResponse** message from the DUT.
7. Check if there is an event with Topic tns1:AccessControl/Duress. If there is no event with such Topic, skip other steps, fail the test and go to the next test.
8. Check that this event is not a Property event (MessageDescription.IsProperty = "false").
9. Check that this event contains Source.SimpleItemDescription item with Name = "AccessPointToken" and Type = "pt:ReferenceToken".
10. Check that if this event contains Data.SimpleItemDescription item with Name = "CredentialToken", then it has Type = "pt:ReferenceToken".
11. Check that if this event contains Data.SimpleItemDescription item with Name = "CredentialHolderName", then it has Type = "xs:string".
12. Check that this event contains Data.SimpleItemDescription item with Name = "Reason" and Type = "xs:string".
13. ONVIF Client will invoke **CreatePullPointSubscription** request with tns1:AccessControl/Duress Topic as Filter and an InitialTerminationTime of timeout1.
14. Verify that the DUT sends a **CreatePullPointSubscriptionResponse** message.
15. Test Operator will invoke tns1:AccessControl/Duress event for any Access Point with Capabilities.Duress = "true".
16. ONVIF Client will invoke **PullMessages** request with a PullMessagesTimeout of 20s and a MessageLimit of 1.
17. Verify that the DUT sends a **PullMessagesResponse** that contains one NotificationMessage. If no NotificationMessage were received repeat step 16.
18. Verify received Notification message (correct value for UTC time, TopicExpression and wsnt:Message).
19. Verify that TopicExpression is equal to tns1:AccessControl/Duress for the Notification message.
20. Verify that the notification contains Source.SimpleItem item with Name = "AccessPointToken" and Value is equal to one of existing Access Point Tokens with Capabilities.Duress = "true" (e.g. complete list of access points contains Access Point with the same token and this Access Point has Capabilities.Duress = "true").
21. Verify that the notification contains Data.SimpleItem item with Name = "Reason" and Value with type is equal to xs:string.

22. Verify that the notification which contains Data.SimpleItem item with Name = «CredentialToken» contains Value with type is equal to pt:ReferenceToken.

23. Verify that the notification which contains Data.SimpleItem item with Name = "CredentialHolderName" contains Value with type is equal to xs:string.

Test Result:

PASS –

- DUT passes all assertions.

FAIL –

- The DUT did not send a **GetEventPropertiesResponse**
- The DUT did not send **CreatePullPointSubscriptionResponse** message.
- The DUT did not send valid SubscriptionReference.
- The DUT did not send a **PullMessagesResponse** message that contains one tns1:AccessControl/Duress event.
- The DUT sent an invalid Notification message (no corresponding Source.SimpleItem or Data.SimpleItem, wrong type of Value fields, invalid AccessPointToken value, invalid CredentialToken, invalid CredentialHolderName, invalid Reason).
- The DUT did not return at least one Access Point at step 3.
- The DUT did not return valid Topic tns1:AccessControl/Duress in **GetEventPropertiesResponse**.

Note: The Subscription Manager has to be deleted at the end of the test either by calling unsubscribe or through a timeout.

Note: The **Renew** has to be used for renew subscription during test, if InitialTerminationTime expires.

Note: Test will fail, if no Notification message is received at step 17 for a certain period of time (Operation Delay should be used in ONVIF Device Test Tool).

Note: If DUT cannot accept the set value to Timeout or MessageLimit, ONVIF Client retries to send the PullMessage message with Timeout and MessageLimit which is contained in PullMessagesFaultResponse.

Note: If DUT cannot accept the set value to a TerminationTime, ONVIF Client retries to send the **Renew** request MinimumTime value which is contained in UnacceptableTerminationTimeFault.

Note: timeout1 will be taken from Subscription Timeout field of ONVIF Device Test Tool.

4.11 Consistency

4.11.1 GET AREA INFO LIST AND GET ACCESS POINT INFO LIST CONSISTENCY

Test Case ID: ACCESSCONTROL-4-1-2

Specification Coverage: GetAccessPointInfoList (ONVIF Access Control Service Specification), GetAreaInfoList (ONVIF Access Control Service Specification)

Feature Under Test: GetAccessPointInfoList, GetAreaInfoList

WSDL Reference: accesscontrol.wsdl

Test Purpose: To verify that Area Info List contains all Areas from Access Point Info List.

Pre-Requirement: Access Control Service was received from the DUT. At least one Access Point is configured and added to the DUT. At least one Area is configured and added to the DUT, if the DUT supports Areas.

Test Configuration: ONVIF Client and DUT

Test Procedure:

1. Start an ONVIF Client.
2. Start the DUT.
3. Get a complete list of access points from the DUT (see [Annex A.1](#))
4. Get a complete list of areas from the DUT (see [Annex A.2](#))
5. Verify that the complete list of areas contains all Areas from AreaTo and AreaFrom elements of a complete access points list.

Test Result:

PASS –

- DUT passes all assertions.

FAIL –

- The DUT returned at least one value in AreaTo or AreaFrom element of complete access points list that was not listed in the complete list of areas.
- The DUT did not return at least one Access Point at step 3.

4.12 Access Point Configuration

4.12.1 ACCESS CONTROL – ADD OR CHANGE ACCESS POINT EVENT

Test Case ID: ACCESSCONTROL-12-1-1

Specification Coverage: tns1:Configuration/AccessPoint/Changed (Access Control Service Specification), GetAccessPointInfo (ONVIF Access Control Service Specification)

Feature Under Test: tns1:Configuration/AccessPoint/Changed

WSDL Reference: event.wsdl, accesscontrol.wsdl

Test Purpose: To verify tns1:Configuration/AccessPoint/Changed event generation after adding new access point or changing access point configuration to the DUT and to verify: tns1:Configuration/AccessPoint/Changed event format.

Pre-Requisite: Event Service was received from the DUT. Access Control Service was received from the DUT. The DUT allows adding or changing Access Points.

Test Configuration: ONVIF Client and DUT

Test Procedure:

1. Start an ONVIF Client.
2. Start the DUT.
3. ONVIF Client will invoke **GetEventProperties** request to retrieve all events supported by the DUT.
4. Verify the **GetEventPropertiesResponse** message from the DUT.
5. Check if there is an event with Topic tns1:Configuration/AccessPoint/Changed. If there is no event with such Topic fail the test and skip other steps.
6. Check that this event isn't a Property event (MessageDescription.IsProperty = "false").
7. Check that this event contains Source.SimpleItemDescription item with Name = "AccessPointToken" and Type = "pt:ReferenceToken".

8. ONVIF Client will invoke **CreatePullPointSubscription** request with `tns1:Configuration/AccessPoint/Changed` Topic as Filter and an `InitialTerminationTime` of `timeout1`.
9. Verify that the DUT sends a **CreatePullPointSubscriptionResponse** message.
10. Test Operator will add Access Point or change Access Point configuration.
11. ONVIF Client will invoke **PullMessages** request with a `PullMessagesTimeout` of 20s and a `MessageLimit` of 1.
12. Verify that the DUT sends a **PullMessagesResponse** that contains one `NotificationMessage`. Repeat step 11 until Notification received.
13. Verify received Notification messages (correct value for UTC time, `TopicExpression` and `wsnt:Message`).
14. Verify that `TopicExpression` is equal to `tns1:Configuration/AccessPoint/Changed` for received message.
15. Verify that notification contains `Source.SimpleItem` item with `Name = "AccessPointToken"` and `Value` with type is equal to `tdc:ReferenceToken`.
16. ONVIF Client will invoke **GetAccessPointInfo** request (Token from Notification message) to retrieve subset of AccessPoint Information from the DUT.
17. Verify the **GetAccessPointInfoResponse** message from the DUT. Verify that requested Access Point was returned.

Test Result:**PASS –**

- DUT passes all assertions.

FAIL –

- The DUT did not send a **GetEventPropertiesResponse**
- The DUT did not send **CreatePullPointSubscriptionResponse** message.
- The DUT did not send **PullMessagesResponse** message.
- The DUT did not send valid `SubscriptionReference`.
- The DUT did not send a **GetAccessPointInfoResponse** with specified Access Point.
- The DUT did not send a Notification message that contains an event `tns1:Configuration/AccessPoint/Changed` with valid `AccessPointToken`.

- The DUT sent an invalid Notification message (invalid AccessPointToken value).

Note: The Subscription Manager has to be deleted at the end of the test either by calling unsubscribe or through a timeout.

Note: ONVIF Client on step 12 will wait Notification messages until expected notification is received or Operation Delay has expired.

Note: The Subscription Manager has to be deleted at the end of the test either by calling unsubscribe or through a timeout.

Note: The **Renew** has to be used for renew subscription during test, if InitialTerminationTime expires.

Note: If DUT cannot accept the set value to Timeout or MessageLimit, ONVIF Client retries to send the PullMessage message with Timeout and MessageLimit which is contained in PullMessagesFaultResponse.

Note: If DUT cannot accept the set value to a TerminationTime, ONVIF Client retries to send the **Renew** request MinimumTime value which is contained in UnacceptableTerminationTimeFault.

Note: timeout1 will be taken from Subscription Timeout field of ONVIF Device Test Tool.

4.12.2 ACCESS CONTROL – REMOVE ACCESS POINT EVENT

Test Case ID: ACCESSCONTROL-12-1-2

Specification Coverage: tns1:Configuration/AccessPoint/Removed (Access Control Service Specification), GetAccessPointInfo (ONVIF Access Control Service Specification)

Feature Under Test: tns1:Configuration/AccessPoint/Removed

WSDL Reference: event.wsdl, accesscontrol.wsdl

Test Purpose: To verify tns1:Configuration/AccessPoint/Removed event generation after removing access point configuration to the DUT and to verify tns1:Configuration/AccessPoint/Removed event format.

Pre-Requisite: Event Service was received from the DUT. Access Control Service was received from the DUT. At least one Access Point is configured and added to the DUT. The DUT supports Access Points remove.

Test Configuration: ONVIF Client and DUT

Test Procedure:

1. Start an ONVIF Client.
2. Start the DUT.
3. ONVIF Client will invoke **GetEventProperties** request to retrieve all events supported by the DUT.
4. Verify the **GetEventPropertiesResponse** message from the DUT.
5. Check if there is an event with Topic tns1:Configuration/AccessPoint/Removed. If there is no event with such Topic, fail the test and skip other steps.
6. Check that this event isn't a Property event (MessageDescription.IsProperty = "false").
7. Check that this event contains Source.SimpleItemDescription item with Name = "AccessPointToken" and Type = "pt:ReferenceToken".
8. ONVIF Client will invoke **CreatePullPointSubscription** request with tns1:Configuration/AccessPoint/Removed Topic as Filter and an InitialTerminationTime of timeout1.
9. Verify that the DUT sends a **CreatePullPointSubscriptionResponse** message.
10. Test Operator will remove Access Point.
11. ONVIF Client will invoke **PullMessages** request with a PullMessagesTimeout of 20s and a MessageLimit of 1.
12. Verify that the DUT sends a **PullMessagesResponse** that contains one NotificationMessage. Repeat step 11 until Notification received.
13. Verify received Notification messages (correct value for UTC time, TopicExpression and wsnt:Message).
14. Verify that TopicExpression is equal to tns1:Configuration/AccessPoint/Removed for received message.
15. Verify that notification contains Source.SimpleItem item with Name = "AccessPointToken" and Value with type is equal to tdc:ReferenceToken.
16. ONVIF Client will invoke **GetAccessPointInfo** request (Token from Notification message) to retrieve subset of Access Point Information from the DUT.
17. Verify the **GetAccessPointInfoResponse** message from the DUT. Check that empty list was returned.

Test Result:**PASS –**

- DUT passes all assertions.

FAIL –

- The DUT did not send a **GetEventPropertiesResponse**
- The DUT did not send **CreatePullPointSubscriptionResponse** message.
- The DUT did not send valid SubscriptionReference.
- The DUT did not send a **GetAccessPointInfoResponse** with empty list.
- The DUT did not send a Notification message that contains an event tns1:Configuration/AccessPoint/Removed with valid AccessPointToken.
- The DUT sent an invalid Notification message (invalid AccessPointToken value).

Note: The Subscription Manager has to be deleted at the end of the test either by calling unsubscribe or through a timeout.

Note: ONVIF Client on step 12 will wait Notification messages until expected notification is received or Operation Delay has expired.

Note: The Subscription Manager has to be deleted at the end of the test either by calling unsubscribe or through a timeout.

Note: The **Renew** has to be used for renew subscription during test, if InitialTerminationTime expires.

Note: If DUT cannot accept the set value to Timeout or MessageLimit, ONVIF Client retries to send the PullMessage message with Timeout and MessageLimit which is contained in PullMessagesFaultResponse.

Note: If DUT cannot accept the set value to a TerminationTime, ONVIF Client retries to send the **Renew** request MinimumTime value which is contained in UnacceptableTerminationTimeFault.

Note: timeout1 will be taken from Subscription Timeout field of ONVIF Device Test Tool.

4.13 Area Configuration

4.13.1 ACCESS CONTROL – ADD OR CHANGE AREA EVENT

Test Case ID: ACCESSCONTROL-13-1-1

Specification Coverage: tns1:Configuration/Area/Change (Access Control Service Specification), GetAreaInfo (ONVIF Access Control Service Specification)

Feature Under Test: tns1:Configuration/Area/Change

WSDL Reference: event.wsdl, accesscontrol.wsdl

Test Purpose: To verify: tns1:Configuration/Area/Change event generation after adding new area or changing area configuration to the DUT and to verify: tns1:Configuration/Area/Change event format.

Pre-Requisite: Event Service was received from the DUT. Access Control Service was received from the DUT. The DUT allows adding or changing Area.

Test Configuration: ONVIF Client and DUT

Test Procedure:

1. Start an ONVIF Client.
2. Start the DUT.
3. ONVIF Client will invoke **GetEventProperties** request to retrieve all events supported by the DUT.
4. Verify the **GetEventPropertiesResponse** message from the DUT.
5. Check if there is an event with Topic tns1:Configuration/Area/Change. If there is no event with such Topic fail the test and skip other steps.
6. Check that this event isn't a Property event (MessageDescription.IsProperty = "false").
7. Check that this event contains Source.SimpleItemDescription item with Name = "AreaToken" and Type = "pt:ReferenceToken".
8. ONVIF Client will invoke **CreatePullPointSubscription** request with tns1:Configuration/Area/Changed Topic as Filter and an InitialTerminationTime of timeout1.
9. Verify that the DUT sends a **CreatePullPointSubscriptionResponse** message.
10. Test Operator will add Area or change Area configuration.
11. ONVIF Client will invoke **PullMessages** request with a PullMessagesTimeout of 20s and a MessageLimit of 1.
12. Verify that the DUT sends a **PullMessagesResponse** that contains one NotificationMessage. Repeat step 11 until Notification received.

13. Verify received Notification messages (correct value for UTC time, TopicExpression and wsnt:Message).
14. Verify that TopicExpression is equal to tns1:Configuration/Area/Change for received message.
15. Verify that notification contains Source.SimpleItem item with Name = "AreaToken" and Value with type is equal to tdc:ReferenceToken.
16. ONVIF Client will invoke GetAreaInfo request (Token from Notification message) to retrieve subset of Area Information from the DUT.
17. Verify the **GetAreaInfoResponse** message from the DUT. Verify that requested Area was returned.

Test Result:**PASS –**

- DUT passes all assertions.

FAIL –

- The DUT did not send a **GetEventPropertiesResponse**
- The DUT did not send **CreatePullPointSubscriptionResponse** message.
- The DUT did not send valid SubscriptionReference.
- The DUT did not send a **GetAreaInfoResponse** with specified Area.
- The DUT did not send a Notification message that contains an event tns1:Configuration/Area/Change with valid AreaToken.
- The DUT sent an invalid Notification message (invalid AreaToken value).

Note: The Subscription Manager has to be deleted at the end of the test either by calling unsubscribe or through a timeout.

Note: ONVIF Client on step 12 will wait Notification messages until expected notification is received or Operation Delay after last notification has expired.

Note: The Subscription Manager has to be deleted at the end of the test either by calling unsubscribe or through a timeout.

Note: The **Renew** has to be used for renew subscription during test, if InitialTerminationTime expires.

Note: If DUT cannot accept the set value to Timeout or MessageLimit, ONVIF Client retries to send the PullMessage message with Timeout and MessageLimit which is contained in PullMessagesFaultResponse.

Note: If DUT cannot accept the set value to a TerminationTime, ONVIF Client retries to send the **Renew** request MinimumTime value which is contained in UnacceptableTerminationTimeFault.

Note: timeout1 will be taken from Subscription Timeout field of ONVIF Device Test Tool.

4.13.2 ACCESS CONTROL – REMOVE AREA EVENT

Test Case ID: ACCESSCONTROL-13-1-2

Specification Coverage: tns1:Configuration/Area/Removed (Access Control Service Specification), GetAreaInfo (ONVIF Access Control Service Specification)

Feature Under Test: tns1:Configuration/Area/Removed

WSDL Reference: event.wsdl, accesscontrol.wsdl

Test Purpose: To verify tns1:Configuration/Area/Removed event generation after removing Area configuration to the DUT and to verify tns1:Configuration/Area/Removed event format.

Pre-Requisite: Event Service was received from the DUT. Access Control Service was received from the DUT. At least one Area is configured and added to the DUT. The DUT supports Area remove.

Test Configuration: ONVIF Client and DUT

Test Procedure:

1. Start an ONVIF Client.
2. Start the DUT.
3. ONVIF Client will invoke **GetEventProperties** request to retrieve all events supported by the DUT.
4. Verify the **GetEventPropertiesResponse** message from the DUT.
5. Check if there is an event with Topic tns1:Configuration/Area/Removed. If there is no event with such Topic fail the test and skip other steps.
6. Check that this event isn't a Property event (MessageDescription.IsProperty = "false").
7. Check that this event contains Source.SimpleItemDescription item with Name = "AreaToken" and Type = "pt:ReferenceToken".

8. ONVIF Client will invoke **CreatePullPointSubscription** request with `tns1:Configuration/Area/Removed` Topic as Filter and an `InitialTerminationTime` of `timeout1`.
9. Verify that the DUT sends a **CreatePullPointSubscriptionResponse** message.
10. Test Operator will remove Area.
11. ONVIF Client will invoke **PullMessages** request with a `PullMessagesTimeout` of 20s and a `MessageLimit` of 1.
12. Verify that the DUT sends a **PullMessagesResponse** that contains one `NotificationMessage`. Repeat step 11 until Notification received.
13. Verify received Notification messages (correct value for UTC time, `TopicExpression` and `wsnt:Message`).
14. Verify that `TopicExpression` is equal to `tns1:Configuration/Area/Removed` for received message.
15. Verify that notification contains `Source.SimpleItem` item with `Name = "AreaToken"` and `Value` with type is equal to `tdc:ReferenceToken`.
16. ONVIF Client will invoke **GetAreaInfo** request (Token from Notification message) to retrieve subset of Area Information from the DUT.
17. Verify the **GetAreaInfoResponse** message from the DUT. Check that empty list was returned.

Test Result:**PASS –**

- DUT passes all assertions.

FAIL –

- The DUT did not send a **GetEventPropertiesResponse**
- The DUT did not send **CreatePullPointSubscriptionResponse** message.
- The DUT did not send valid `SubscriptionReference`.
- The DUT did not send a **GetAreaInfoResponse** with empty list.
- The DUT did not send a Notification message that contains an event `tns1:Configuration/Area/Removed` with valid `AreaToken`.
- The DUT sent an invalid Notification message (invalid `AreaToken` value).

Note: The Subscription Manager has to be deleted at the end of the test either by calling unsubscribe or through a timeout.

Note: ONVIF Client on step 12 will wait Notification messages until expected notification is received or Operation Delay after last notification has expired.

Note: The Subscription Manager has to be deleted at the end of the test either by calling unsubscribe or through a timeout.

Note: The **Renew** has to be used for renew subscription during test, if InitialTerminationTime expires.

Note: If DUT cannot accept the set value to Timeout or MessageLimit, ONVIF Client retries to send the PullMessage message with Timeout and MessageLimit which is contained in PullMessagesFaultResponse.

Note: If DUT cannot accept the set value to a TerminationTime, ONVIF Client retries to send the **Renew** request MinimumTime value which is contained in UnacceptableTerminationTimeFault.

Note: timeout1 will be taken from Subscription Timeout field of ONVIF Device Test Tool.

Annex A Helper Procedures and Additional Notes

A.1 Get Complete Access Point Info List

The following algorithm will be used to get a complete list of Access Points:

1. ONVIF Client will invoke **GetAccessPointInfoList** request (no Limit, no StartReference) to retrieve the first part of Access Point Information list from the DUT.
2. Verify the **GetAccessPointInfoListResponse** message from the DUT.
3. If **GetAccessPointInfoListResponse** message contains NextStartReference, repeat steps 1-2 with StartReference = [current NextStartReference]. Otherwise, skip other steps and finalize getting complete access point list.

The complete ordered list of access points with information will be made by the means of uniting all **GetAccessPointInfoListResponse** messages. Also the total number of access points will be calculated.

A.2 Get Complete Area Info List

The following algorithm will be used to get a complete list of Areas:

1. ONVIF Client will invoke **GetAreaInfoList** request (no Limit, no StartReference) to retrieve the first part of Area Information list from the DUT.
2. Verify the **GetAreaInfoListResponse** message from the DUT.
3. If **GetAreaInfoListResponse** message contains NextStartReference, repeat steps 1-2 with StartReference = [current NextStartReference]. Otherwise, skip other steps and finalize getting complete area list.

The complete ordered list of areas with information will be made by the means of uniting all **GetAreaInfoListResponse** messages. Also the total number of areas will be calculated.