

# ONVIF<sup>™</sup>

## Door Control Device Test Specification

Version 17.12

December 2017

© 2017 ONVIF, Inc. All rights reserved.

Recipients of this document may copy, distribute, publish, or display this document so long as this copyright notice, license and disclaimer are retained with all copies of the document. No license is granted to modify this document.

THIS DOCUMENT IS PROVIDED "AS IS," AND THE CORPORATION AND ITS MEMBERS AND THEIR AFFILIATES, MAKE NO REPRESENTATIONS OR WARRANTIES, EXPRESS OR IMPLIED, INCLUDING BUT NOT LIMITED TO, WARRANTIES OF MERCHANTABILITY, FITNESS FOR A PARTICULAR PURPOSE, NON-INFRINGEMENT, OR TITLE; THAT THE CONTENTS OF THIS DOCUMENT ARE SUITABLE FOR ANY PURPOSE; OR THAT THE IMPLEMENTATION OF SUCH CONTENTS WILL NOT INFRINGE ANY PATENTS, COPYRIGHTS, TRADEMARKS OR OTHER RIGHTS.

IN NO EVENT WILL THE CORPORATION OR ITS MEMBERS OR THEIR AFFILIATES BE LIABLE FOR ANY DIRECT, INDIRECT, SPECIAL, INCIDENTAL, PUNITIVE OR CONSEQUENTIAL DAMAGES, ARISING OUT OF OR RELATING TO ANY USE OR DISTRIBUTION OF THIS DOCUMENT, WHETHER OR NOT (1) THE CORPORATION, MEMBERS OR THEIR AFFILIATES HAVE BEEN ADVISED OF THE POSSIBILITY OF SUCH DAMAGES, OR (2) SUCH DAMAGES WERE REASONABLY FORESEEABLE, AND ARISING OUT OF OR RELATING TO ANY USE OR DISTRIBUTION OF THIS DOCUMENT. THE FOREGOING DISCLAIMER AND LIMITATION ON LIABILITY DO NOT APPLY TO, INVALIDATE, OR LIMIT REPRESENTATIONS AND WARRANTIES MADE BY THE MEMBERS AND THEIR RESPECTIVE AFFILIATES TO THE CORPORATION AND OTHER MEMBERS IN CERTAIN WRITTEN POLICIES OF THE CORPORATION.

## REVISION HISTORY

Vers.	Date	Description
13.06	Jun, 2013	First issue
13.12	Dec, 2013	Minor updates
14.06	Jun, 2014	The following tests were updated with Test Case ID change: ACCESS DOOR BLOCK DOOR DOUBLE LOCK DOOR LOCK DOOR UNLOCK DOOR LOCK DOWN DOOR LOCK DOWN RELEASE DOOR LOCK OPEN DOOR LOCK OPEN RELEASE DOOR
17.12	Aug 16, 2017	Current document name was changed from Door Control Test Specification to Door Control Device Test Specification.  The document formatting was updated.

**Table of Contents**

- 1 Introduction ..... 7**
  - 1.1 Scope ..... 7
    - 1.1.1 Capabilities ..... 8
    - 1.1.2 General ..... 8
    - 1.1.3 Door Control ..... 8
    - 1.1.4 Consistency ..... 9
    - 1.1.5 Property Events ..... 9
    - 1.1.6 Door Change Events ..... 9
- 2 Terms and Definitions ..... 10**
  - 2.1 Definitions ..... 10
- 3 Test Overview ..... 11**
  - 3.1 Test Setup ..... 11
    - 3.1.1 Network Configuration for DUT ..... 11
  - 3.2 Prerequisites ..... 12
  - 3.3 Test Policy ..... 14
    - 3.3.1 Capabilities ..... 14
    - 3.3.2 General ..... 14
    - 3.3.3 Door Control ..... 15
    - 3.3.4 Consistency ..... 16
    - 3.3.5 Property Events ..... 17
    - 3.3.6 Door Change Events ..... 18
- 4 Door Control Test Cases ..... 20**
  - 4.1 Capabilities ..... 20
    - 4.1.1 DOOR CONTROL SERVICE CAPABILITIES ..... 20
    - 4.1.2 GET SERVICES AND GET DOOR CONTROL SERVICE CAPABILITIES  
CONSISTENCY ..... 21
  - 4.2 General ..... 22
    - 4.2.1 GET DOOR STATE ..... 22
    - 4.2.2 GET DOOR STATE WITH INVALID TOKEN ..... 23
    - 4.2.3 GET DOOR INFO ..... 24



- 4.2.4 GET DOOR INFO WITH INVALID TOKEN ..... 25
- 4.2.5 GET DOOR INFO LIST – LIMIT ..... 27
- 4.2.6 GET DOOR INFO LIST – START REFERENCE AND LIMIT ..... 28
- 4.2.7 GET DOOR INFO LIST – NO LIMIT ..... 31
- 4.2.8 GET DOOR INFO – TOO MANY ITEMS ..... 32
- 4.3 Door Control ..... 33
  - 4.3.1 ACCESS DOOR WITH INVALID TOKEN ..... 33
  - 4.3.2 BLOCK DOOR WITH INVALID TOKEN ..... 34
  - 4.3.3 DOUBLE LOCK DOOR WITH INVALID TOKEN ..... 35
  - 4.3.4 LOCK DOOR WITH INVALID TOKEN ..... 36
  - 4.3.5 UNLOCK DOOR WITH INVALID TOKEN ..... 37
  - 4.3.6 LOCK DOWN DOOR WITH INVALID TOKEN ..... 37
  - 4.3.7 LOCK DOWN RELEASE DOOR WITH INVALID TOKEN ..... 38
  - 4.3.8 LOCK OPEN DOOR WITH INVALID TOKEN ..... 39
  - 4.3.9 LOCK OPEN RELEASE DOOR WITH INVALID TOKEN ..... 40
  - 4.3.10 ACCESS DOOR – COMMAND NOT SUPPORTED ..... 41
  - 4.3.11 BLOCK DOOR – COMMAND NOT SUPPORTED ..... 42
  - 4.3.12 DOUBLE LOCK DOOR – COMMAND NOT SUPPORTED ..... 43
  - 4.3.13 LOCK DOOR – COMMAND NOT SUPPORTED ..... 44
  - 4.3.14 UNLOCK DOOR – COMMAND NOT SUPPORTED ..... 45
  - 4.3.15 LOCK DOWN DOOR – COMMAND NOT SUPPORTED ..... 46
  - 4.3.16 LOCK DOWN RELEASE DOOR – COMMAND NOT SUPPORTED ..... 47
  - 4.3.17 LOCK OPEN DOOR – COMMAND NOT SUPPORTED ..... 48
  - 4.3.18 LOCK OPEN RELEASE DOOR – COMMAND NOT SUPPORTED ..... 49
  - 4.3.19 ACCESS DOOR ..... 50
  - 4.3.20 BLOCK DOOR ..... 53
  - 4.3.21 DOUBLE LOCK DOOR ..... 56
  - 4.3.22 LOCK DOOR ..... 58
  - 4.3.23 UNLOCK DOOR ..... 62
  - 4.3.24 LOCK OPEN DOOR ..... 65
  - 4.3.25 LOCK OPEN RELEASE DOOR ..... 67

- 4.3.26 LOCK DOWN DOOR ..... 70
- 4.3.27 LOCK DOWN RELEASE DOOR ..... 73
- 4.4 Consistency ..... 76
  - 4.4.1 GET ACCESS POINT INFO LIST AND GET DOOR INFO LIST CONSISTENCY ..... 76
- 4.5 Property Events ..... 77
  - 4.5.1 DOOR CONTROL – DOOR MODE EVENT ..... 77
  - 4.5.2 DOOR CONTROL – DOOR PHYSICAL STATE EVENT ..... 80
  - 4.5.3 DOOR CONTROL – DOOR PHYSICAL STATE EVENT STATE CHANGE ... 83
  - 4.5.4 DOOR CONTROL – DOUBLE LOCK PHYSICAL STATE EVENT ..... 85
  - 4.5.5 DOOR CONTROL – DOUBLE LOCK PHYSICAL STATE EVENT STATE CHANGE ..... 88
  - 4.5.6 DOOR CONTROL – LOCK PHYSICAL STATE EVENT ..... 90
  - 4.5.7 DOOR CONTROL – LOCK PHYSICAL STATE EVENT STATE CHANGE .... 93
  - 4.5.8 DOOR CONTROL – DOOR TAMPER EVENT ..... 96
  - 4.5.9 DOOR CONTROL – DOOR TAMPER EVENT STATE CHANGE ..... 99
  - 4.5.10 DOOR CONTROL – DOOR ALARM EVENT ..... 101
  - 4.5.11 DOOR CONTROL – DOOR ALARM EVENT STATE CHANGE ..... 104
  - 4.5.12 DOOR CONTROL – DOOR FAULT EVENT ..... 106
  - 4.5.13 DOOR CONTROL – DOOR FAULT EVENT STATE CHANGE ..... 109
- 4.6 Door Configuration ..... 111
  - 4.6.1 DOOR CONTROL – ADD OR CHANGE DOOR EVENT ..... 111
  - 4.6.2 DOOR CONTROL – REMOVE DOOR EVENT ..... 114
- A Helper Procedures and Additional Notes ..... 117**
  - A.1 Get Complete Door Info List ..... 117
  - A.2 Get Complete Access Point Info List ..... 117
  - A.3 Catching of Initialized event ..... 117
  - A.4 User Interaction Process ..... 118
  - A.5 Door's transition to Locked state ..... 119



# 1 Introduction

The goal of the ONVIF test specification set is to make it possible to realize fully interoperable IP physical security implementation from different vendors. The set of ONVIF test specification describes the test cases need to verify the [ONVIF Network Interface Specs] and [ONVIF Conformance] requirements. And also the test cases are to be basic inputs for some Profile specification requirements. It also describes the test framework, test setup, pre-requisites, test policies needed for the execution of the described test cases.

This ONVIF Door Control Test Specification acts as a supplementary document to the [ONVIF Network Interface Specs], illustrating test cases need to be executed and passed. And also this specification acts as an input document to the development of test tool which will be used to test the ONVIF device implementation conformance towards ONVIF standard. This test tool is referred as ONVIF Client hereafter.

## 1.1 Scope

This ONVIF Door Control Test Specification defines and regulates the conformance testing procedure for the ONVIF conformant devices. Conformance testing is meant to be functional black-box testing. The objective of this specification is to provide the test cases to test individual requirements of ONVIF devices according to ONVIF Door Control service which is defined in [ONVIF Network Interface Specs].

The principal intended purposes are:

1. Provide self-assessment tool for implementations.
2. Provide comprehensive test suite coverage for [ONVIF Network Interface Specs].

This specification does not address the following:

1. Product use cases and non-functional (performance and regression) testing.
2. SOAP Implementation Interoperability test i.e. Web Service Interoperability Basic Profile version 2.0 (WS-I BP 2.0).
3. Network protocol implementation Conformance test for HTTP, HTTPS, RTP protocol.
4. Wi-Fi Conformance test

The set of ONVIF Test Specification will not cover the complete set of requirements as defined in [ONVIF Network Interface Specs]; instead it would cover its subset.

This ONVIF Door Control Test Specification covers ONVIF Door Control service and Door Control Events which are a functional block of [ONVIF Network Interface Specs]. The following sections give a brief overview and scope of each functional block.

## 1.1.1 Capabilities

Capabilities test cases cover verification to get Door Control Service capabilities. It means that the following commands are covered by these test cases:

- GetServices (Device Management Service);
- GetServiceCapabilities.

## 1.1.2 General

General test cases cover verification to get Door list, information and state. It means that the following commands are covered by these test cases:

- GetDoorInfo;
- GetDoorInfoList;
- GetDoorState.

## 1.1.3 Door Control

Door Control test cases cover verification of door control commands and door state change. It means that the following commands and events are covered by these test cases:

- tns1:Door/State/DoorMode;
- AccessDoor;
- BlockDoor;
- DoubleLockDoor;
- LockDoor;
- UnlockDoor;
- LockDownDoor;
- LockDownReleaseDoor;
- LockOpenDoor;
- LockOpenReleaseDoor.



## 1.1.4 Consistency

Consistency test cases cover verification of consistency between different entities and commands. It means that consistency between the following entities is covered by these test cases:

- Access Point Info and Door Info.

## 1.1.5 Property Events

Property events test cases cover verification of property events provided by Door Control Service. It means that the following events are covered by these test cases:

- tns1:Door/State/DoorMode;
- tns1:Door/State/DoorPhysicalState;
- tns1:Door/State/LockPhysicalState;
- tns1:Door/State/DoubleLockPhysicalState;
- tns1:Door/State/DoorAlarm;
- tns1:Door/State/DoorTamper;
- tns1:Door/State/DoorFault.

## 1.1.6 Door Change Events

Door change events test cases cover verification of door change events provided by Door Control Service. It means that the following events are covered by these test cases:

- tns1:Configuration/Door/Change;
- tns1:Configuration/Door/Removed.

## 2 Terms and Definitions

### 2.1 Definitions

This section defines terms that are specific to the ONVIF Door Control Service and tests. For a list of applicable general terms and definitions, please see [ONVIF Base Test].

<b>Credential</b>	A physical/tangible object, a piece of knowledge, or a facet of a person's physical being, that enables an individual access to a given physical facility or computer-based information system.
<b>Credential (Number)</b>	A sequence of bytes uniquely identifying a credential at an access point.
<b>Door</b>	A physical door, barrier, turnstile, etc which can be controlled remotely and restricts access between two areas. A door is usually equipped with an electronic lock and a sensor.
<b>Door Alarm</b>	An abnormal state of the door where door is forced open or held open beyond the permitted time duration
<b>Door Lock</b>	A device that secures a door to prevent access, except when explicitly allowed by the access control system. Lock types include electromagnet, electric strike, etc.
<b>Door Mode</b>	Logical state of the door indicating whether the door is locked, unlocked, blocked, locked down or locked open etc.
<b>Door Monitor</b>	Also known as a Door Contact Sensor
<b>Lock</b>	An operation after which a door is locked and alarm is unmasked.
<b>Momentary Access</b>	An operation which invokes the same logic as upon normal access being granted to a credential.
<b>Tamper Detector</b>	Mechanism commonly available for doors, access points and controllers to detect physical tamper
<b>Unlock</b>	An operation to allow a door to be freely used for passage without any door alarms being triggered.

## 3 Test Overview

This section provides information the test setup procedure and required prerequisites, and the test policies that should be followed for test case execution.

### 3.1 Test Setup

#### 3.1.1 Network Configuration for DUT

The generic test configuration for the execution of test cases defined in this document is as shown below (Figure 4.1).

Based on the individual test case requirements, some of the entities in the below setup may not be needed for the execution of those corresponding test cases.

**Figure 3.1. Test Configuration for DUT**

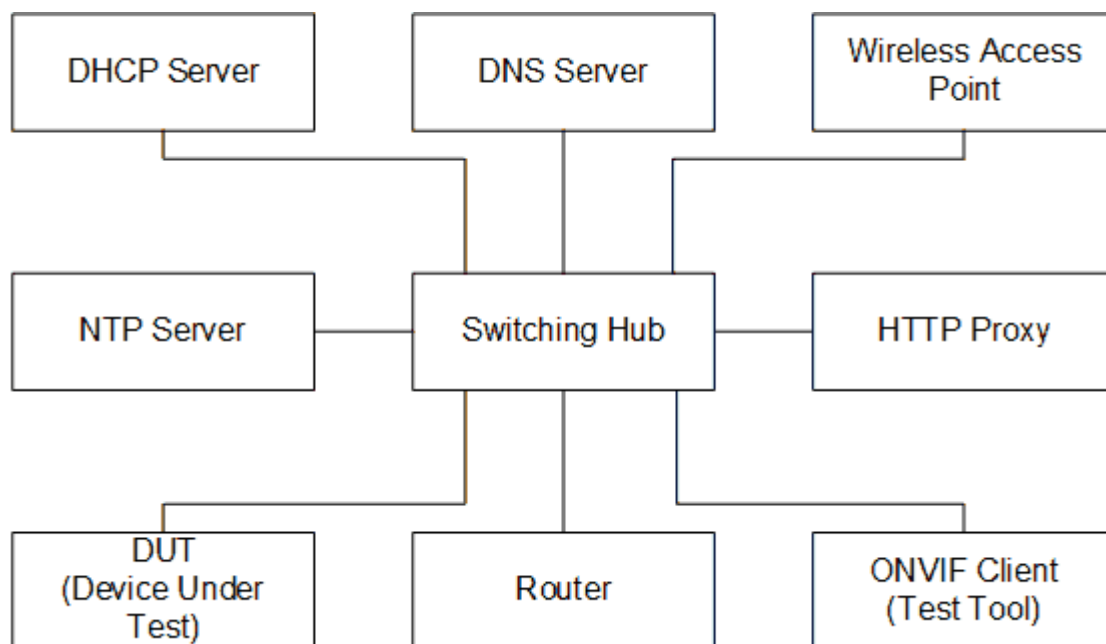

**DUT:** ONVIF device to be tested. Hereafter, this is referred to as DUT (Device Under Test).

**ONVIF Client (Test Tool):** Tests are executed by this system and it controls the behavior of the DUT. It handles both expected and unexpected behavior.

**HTTP Proxy:** provides facilitation in case of RTP and RTSP tunneling over HTTP.

**Wireless Access Point:** provides wireless connectivity to the devices that support wireless connection.

**DNS Server:** provides DNS related information to the connected devices.

**DHCP Server:** provides IPv4 Address to the connected devices.

**NTP Server:** provides time synchronization between ONVIF Client and DUT.

**Switching Hub:** provides network connectivity among all the test equipments in the test environment. All devices should be connected to the Switching Hub.

**Router:** provides router advertisements for IPv6 configuration.

## 3.2 Prerequisites

The pre-requisites for executing the test cases described in this Test Specification are:

- The DUT shall be configured with an IPv4 address.
- The DUT shall be IP reachable [in the test configuration].
- The DUT shall be able to be discovered by the Test Tool.
- The DUT shall be configured with the time, i.e. manual configuration of UTC time and if NTP is supported by the DUT then NTP time shall be synchronized with NTP Server.
- The DUT time and Test tool time shall be synchronized with each other either manually or by a common NTP server.
- Test Operator shall configure Operation Delay properly so that it would have enough time to receive Notification messages for the following test cases for ONVIF Device Test Tool (see test description for more details):
  - [4.3.19 ACCESS DOOR](#)
  - [4.3.20 BLOCK DOOR](#)
  - [4.3.21 DOUBLE LOCK DOOR](#)
  - [4.3.22 LOCK DOOR](#)
  - [4.3.23 UNLOCK DOOR](#)
  - [4.3.24 LOCK OPEN DOOR](#)
  - [4.3.25 LOCK OPEN RELEASE DOOR](#)
  - [4.3.26 LOCK DOWN DOOR](#)

- [4.3.27 LOCK DOWN RELEASE DOOR](#)
- [4.5.1 DOOR CONTROL – DOOR MODE EVENT](#)
- [4.5.2 DOOR CONTROL – DOOR PHYSICAL STATE EVENT](#)
- [4.5.3 DOOR CONTROL – DOOR PHYSICAL STATE EVENT STATE CHANGE](#)
- [4.5.4 DOOR CONTROL – DOUBLE LOCK PHYSICAL STATE EVENT](#)
- [4.5.5 DOOR CONTROL – DOUBLE LOCK PHYSICAL STATE EVENT STATE CHANGE](#)
- [4.5.6 DOOR CONTROL – LOCK PHYSICAL STATE EVENT](#)
- [4.5.7 DOOR CONTROL – LOCK PHYSICAL STATE EVENT STATE CHANGE](#)
- [4.5.8 DOOR CONTROL – DOOR TAMPER EVENT](#)
- [4.5.9 DOOR CONTROL – DOOR TAMPER EVENT STATE CHANGE](#)
- [4.5.10 DOOR CONTROL – DOOR ALARM EVENT](#)
- [4.5.11 DOOR CONTROL – DOOR ALARM EVENT STATE CHANGE](#)
- [4.5.12 DOOR CONTROL – DOOR FAULT EVENT](#)
- [4.5.13 DOOR CONTROL – DOOR FAULT EVENT STATE CHANGE](#)
- [4.6.1 DOOR CONTROL – ADD OR CHANGE DOOR EVENT](#)
- [4.6.2 DOOR CONTROL – REMOVE DOOR EVENT](#)
- At least one Door is configured and added to the DUT.
- At least one Door with Access capability is configured and added to the DUT, if Access capability is supported by the DUT.
- At least one Door with Block capability is configured and added to the DUT, if Block capability is supported by the DUT.
- At least one Door with Double Lock capability is configured and added to the DUT, if Double Lock capability is supported by the DUT.
- At least one Door with Lock capability is configured and added to the DUT, if Lock capability is supported by the DUT.
- At least one Door with Unlock capability is configured and added to the DUT, if Unlock capability is supported by the DUT.

- At least one Door with Lock Down capability is configured and added to the DUT, if Lock Down capability is supported by the DUT.
- At least one Door with Lock Open capability is configured and added to the DUT, if Lock Open capability is supported by the DUT.
- At least one Door with Door Monitor capability is configured and added to the DUT, if Door Monitor capability is supported by the DUT.
- At least one Door with Lock Monitor capability is configured and added to the DUT, if Lock Monitor capability is supported by the DUT.
- At least one Door with Double Lock Monitor capability is configured and added to the DUT, if Double Lock Monitor capability is supported by the DUT.
- At least one Door with Tamper capability is configured and added to the DUT, if Tamper capability is supported by the DUT.
- At least one Door with Alarm capability is configured and added to the DUT, if Alarm capability is supported by the DUT.
- At least one Door with Fault capability is configured and added to the DUT, if Fault capability is supported by the DUT.

### 3.3 Test Policy

This section describes the test policies specific to the test case execution of each functional block.

The DUT shall adhere to the test policies defined in this section.

#### 3.3.1 Capabilities

DUT shall give the Door Control Service entry point by GetServices command, if DUT supports this service. Otherwise, these test cases will be skipped.

DUT shall support GetServices and GetServiceCapabilities command.

Please, refer to [Section 4.1](#) for Capabilities Test Cases.

#### 3.3.2 General

DUT shall give the Door Control Service entry point by GetServices command, if DUT supports this service. Otherwise, these test cases will be skipped.

DUT shall support GetServices and GetServiceCapabilities command.

DUT shall support at least one Door. And also at least one Door shall be added and configured on device.

DUT shall support the following commands:

- GetDoorInfo
- GetDoorInfoList
- GetDoorState

DUT shall not return any fault, if GetDoorInfo was invoked for non-exciting Door token. Such tokens shall be ignored.

DUT shall not return more items in GetDoorInfo and GetDoorInfoList responses than specified in service capabilities by MaxLimit.

DUT shall not return more items in GetDoorInfoList response than specified by Limit parameter in a request.

DUT shall return SOAP 1.2 fault message (InvalidArgs/TooManyItems), if more items than MaxLimit was requested by GetDoorInfo command.

DUT should return SOAP 1.2 fault message (InvalidArgVal/NotFound), if GetDoorState command was invoked for non-exciting Door token.

Please, refer to [Section 4.2](#) for General Test Cases.

### 3.3.3 Door Control

DUT shall give the Door Control Service entry point and Event Service entry point by GetServices command, if DUT supports Door Control service. Otherwise, these test cases will be skipped.

DUT shall support GetServiceCapabilities command.

DUT shall support following property events:

- tns1:Door/State/DoorMode

DUT shall return capabilities for each specific door.

If DUT returns Access capability as supported by door, then DUT shall support AccessDoor command for this door. Otherwise, DUT should return SOAP 1.2 fault message.

If DUT returns Block capability as supported by door, then DUT shall support BlockDoor command for this door. Otherwise, DUT should return SOAP 1.2 fault message.

If DUT returns DoubleLock capability as supported by door, then DUT shall support DoubleLockDoor command for this door. Otherwise DUT should return SOAP 1.2 fault message.

If DUT returns Lock capability as supported by door, then DUT shall support LockDoor command for this door. Otherwise, DUT should return SOAP 1.2 fault message.

If DUT returns Unlock capability as supported by door, then DUT shall support UnlockDoor command for this door. Otherwise, DUT should return SOAP 1.2 fault message.

If DUT returns LockDown capability as supported by door, then DUT shall support LockDownDoor and LockDownReleaseDoor command for this door. Otherwise, DUT should return SOAP 1.2 fault message.

If DUT returns LockOpen capability as supported by door, then DUT shall support LockOpenDoor and LockOpenReleaseDoor command for this door. Otherwise, DUT should return SOAP 1.2 fault message.

DUT should return SOAP 1.2 fault message (InvalidArgVal/NotFound), if AccessDoor, BlockDoor, DoubleLockDoor, LockDoor, UnlockDoor, LockDownDoor, LockDownReleaseDoor, LockOpenDoor, or LockOpenReleaseDoor command was invoked for non-exciting Door token.

DUT shall support Pull Point Subscription and Topic Expression filter.

DUT shall generate property events with initial state after subscription was done.

DUT shall generate property events with current state after corresponding properties were changed.

Please, refer to [Section 4.3](#) for Door Control Test Cases.

### 3.3.4 Consistency

DUT shall give the Door Control Service entry point by GetServices command, if DUT supports this service. Otherwise, these test cases will be skipped.

DUT shall support at least one Access Point. And also at least one Access Point shall be added and configured on a device.

DUT shall support at least one Door. And also at least one Door shall be added and configured on a device.

DUT shall support the following commands:

- GetAccessPointInfoList
- GetDoorInfoList



- DUT shall not return other Door tokens, than listed in GetAccessPointInfoList responses, in Entity field of GetAccessPointInfo's if Type is skipped or equal to tdc:Door.

Please, refer to [Section 4.4](#) for Consistency Test Cases.

### 3.3.5 Property Events

DUT shall give the Door Control Service entry point and Event Service entry point by GetServices command, if DUT supports Door Control service. Otherwise, these test cases will be skipped.

DUT shall support GetServiceCapabilities command.

DUT shall support following property events:

- tns1:Door/State/DoorMode

DUT shall return capabilities for each specific door.

If DUT returns DoorMonitor capability as supported by door, then DUT shall support the following event for this door:

- tns1:Door/State/DoorPhysicalState

If DUT returns DoubleLockMonitor capability as supported by door, then DUT shall support the following event for this door:

- tns1:Door/State/DoubleLockPhysicalState

If DUT returns LockMonitor capability as supported by door, then DUT shall support the following event for this door:

- tns1:Door/State/LockPhysicalState

If DUT returns Tamper capability as supported by door, then DUT shall support the following event for this door:

- tns1:Door/State/DoorTamper

If DUT returns Alarm capability as supported by door, then DUT shall support the following event for this door:

- tns1:Door/State/DoorAlarm

If DUT returns Fault capability as supported by door, then DUT shall support the following event for this door:

- tns1:Door/State/DoorFault

DUT shall support GetEventProperties command and return all supported events in TopicSet.

DUT shall support Pull Point Subscription and Topic Expression filter.

DUT shall generate property events with initial state after subscription was done.

DUT shall generate property events with current state after corresponding properties were changed.

A test operator shall manually change the following properties if required:

- DoorPhysicalState
- LockPhysicalState
- DoubleLockPhysicalState
- Alarm
- Tamper
- Fault

Please, refer to [Section 4.5](#) for Property Events Test Cases.

### 3.3.6 Door Change Events

DUT shall give the Door Control Service entry point and Event Service entry point by GetServices command, if DUT supports Door Control service. Otherwise, these test cases will be skipped.

DUT shall support GetEventProperties command and return all supported events in TopicSet.

DUT shall support Pull Point Subscription and Topic Expression filter.

If DUT supports adding or changing doors, then DUT shall support the following events:

- tns1:Configuration/Door/Change.

If DUT returns tns1:Configuration/Door/Change topic in GetEventProperties command, then DUT should have possibility to invoke it.

If DUT supports removing doors, then DUT shall support the following events:

- tns1:Configuration/Door/Removed

If DUT returns tns1:Configuration/Door/Removed topic in GetEventProperties command, then DUT should have possibility to invoke it.

A test operator shall manually invoke following events if required:

- tns1:Configuration/Door/Change
- tns1:Configuration/Door/Removed

Please, refer to [Section 4.6](#) for Door Change events Test Cases.

## 4 Door Control Test Cases

### 4.1 Capabilities

#### 4.1.1 DOOR CONTROL SERVICE CAPABILITIES

**Test Case ID:** DOORCONTROL-1-1-1

**Specification Coverage:** Capability exchange (Specification Coverage), `GetServiceCapabilities` (ONVIF Door Control Service Specification)

**Feature Under Test:** `GetServiceCapabilities` (for Door Control Service)

**WSDL Reference:** doorcontrol.wsdl

**Test Purpose:** To verify DUT Door Control Service Capabilities.

**Pre-Requisite:** Door Control Service was received from the DUT.

**Test Configuration:** ONVIF Client and DUT

**Test Procedure:**

1. Start an ONVIF Client.
2. Start the DUT.
3. ONVIF Client will invoke **GetServiceCapabilities** request to retrieve door control service capabilities of the DUT.
4. Verify the **GetServiceCapabilitiesResponse** from the DUT. Verify that `MaxLimit` is greater than zero.

**Test Result:**

**PASS –**

- DUT passes all assertions.

**FAIL –**

- The DUT did not send valid **GetServiceCapabilitiesResponse**.
- The DUT returned `MaxLimit` less than zero.

## 4.1.2 GET SERVICES AND GET DOOR CONTROL SERVICE CAPABILITIES CONSISTENCY

**Test Case ID:** DOORCONTROL-1-1-2

**Specification Coverage:** Capability exchange (Specification Coverage), GetServiceCapabilities (ONVIF Door Control Service Specification)

**Feature Under Test:** GetServices, GetServiceCapabilities (for Door Control Service)

**WSDL Reference:** devicemgmt.wsdl, doorcontrol.wsdl

**Test Purpose:** To verify Get Services and Door Control Service Capabilities consistency.

**Pre-Requisite:** None.

**Pre-Requisite:** Access Rules Service is received from the DUT.

**Test Configuration:** ONVIF Client and DUT

**Test Procedure:**

1. Start an ONVIF Client.
2. Start the DUT.
3. ONVIF Client will invoke **GetServices** request (IncludeCapability = true) to retrieve all services of the DUT with service capabilities.
4. Verify the **GetServicesResponse** message from the DUT.
5. ONVIF Client will invoke **GetServiceCapabilities** request to retrieve Door Control service capabilities of the DUT.
6. Verify the **GetServiceCapabilitiesResponse** message from the DUT.

**Test Result:**

**PASS –**

- DUT passes all assertions.

**FAIL –**

- The DUT did not send valid **GetServicesResponse** message.
- The DUT did not send valid **GetServiceCapabilitiesResponse** message.

- The DUT sent different Capabilities in **GetServicesResponse** message and in **GetServiceCapabilitiesResponse** message.

**Note:** Service will be defined as Door Controller service if it has Namespace element that is equal to “http://www.onvif.org/ver10/doorcontrol/wsd”.

**Note:** Capabilities in GetServicesResponse message and in GetServiceCapabilitiesResponse message will be assumed as different in the following cases:

- MaxLimit attribute values are different.

## 4.2 General

### 4.2.1 GET DOOR STATE

**Test Case ID:** DOORCONTROL-2-1-1

**Specification Coverage:** GetDoorState (ONVIF Door Control Service Specification)

**Feature Under Test:** GetDoorState

**WSDL Reference:** doorcontrol.wsd

**Test Purpose:** To verify Get Door State.

**Pre-Requisite:** Door Control Service was received from the DUT. At least one Door is configured and added to the DUT.

**Test Configuration:** ONVIF Client and DUT

**Test Procedure:**

1. Start an ONVIF Client.
2. Start the DUT.
3. Get a complete list of doors from the DUT (see [Annex A.1](#)).
4. ONVIF Client will invoke **GetDoorState** request (Token = “Token1”, where Token1 is the first DoorInfo.token from the complete list of doors at step 3) to retrieve current state of the door.
5. Verify the **GetDoorStateResponse** message from the DUT.
6. Check that if DoorInfo.Capabilities.DoorMonitor = “true”, than DoorState.DoorPhysicalState is present. Otherwise, if DoorInfo.Capabilities.DoorMonitor = “false”, then check that DoorState.DoorPhysicalState is skipped.

7. Check that if DoorInfo.Capabilities.LockMonitor = "true", than DoorState.LockPhysicalState is present. Otherwise, if DoorInfo.Capabilities.LockMonitor = "false", then check that DoorState.LockPhysicalState is skipped.
8. Check that if DoorInfo.Capabilities.DoubleLockMonitor = "true", than DoorState.DoubleLockPhysicalState is present. Otherwise, if DoorInfo.Capabilities.DoubleLockMonitor = "false", then check that DoorState.DoubleLockPhysicalState is skipped.
9. Check that if DoorInfo.Capabilities.Alarm = "true", than DoorState.Alarm is present. Otherwise if DoorInfo.Capabilities.Alarm = "false", then check that DoorState.Alarm is skipped.
10. Check that if DoorInfo.Capabilities.Tamper = "true", than DoorState.Tamper is present. Otherwise, if DoorInfo.Capabilities.Tamper = "false", than check that DoorState.Tamper is skipped.
11. Check that if DoorInfo.Capabilities.Fault = "true", than DoorState.Fault is present. Otherwise, if DoorInfo.Capabilities.Fault = "false", then check that DoorState.Fault is skipped.
12. Repeat steps 4-11 for all other tokens from the complete list of doors at step 3.

**Test Result:****PASS –**

- DUT passes all assertions.

**FAIL –**

- The DUT did not send valid **GetDoorStateResponse** message.
- The DUT returned DoorState which contains unsupported monitors (DoorPhysicalState, LockPhysicalState, DoubleLockPhysicalState, Alarm, Tamper, and Fault).
- The DUT returned DoorState which does not contain supported monitors (DoorPhysicalState, LockPhysicalState, DoubleLockPhysicalState, Alarm, Tamper, and Fault).
- The DUT did not return at least one Door at step 3.

**Note:** If the DUT does not return any DoorInfo on a complete list of doors at step 3, skip steps 4-12, fail the test and go to the next test.

## 4.2.2 GET DOOR STATE WITH INVALID TOKEN

**Test Case ID:** DOORCONTROL-2-1-2

**Specification Coverage:** GetDoorState (ONVIF Door Control Service Specification)

**Feature Under Test:** GetDoorState

**WSDL Reference:** doorcontrol.wsdl

**Test Purpose:** To verify Get Door State List with invalid Token.

**Pre-Requisite:** Door Control Service address was received from the DUT.

**Test Configuration:** ONVIF Client and DUT

**Test Procedure:**

1. Start an ONVIF Client.
2. Start the DUT.
3. ONVIF Client will invoke **GetDoorState** request (invalid Token).
4. The DUT will generate SOAP 1.2 fault message (**InvalidArgVal/NotFound**).

**Test Result:**

**PASS –**

- DUT passes all assertions.

**FAIL –**

- The DUT did not send SOAP 1.2 fault message.
- The DUT sent incorrect SOAP 1.2 fault message (fault code, namespace, etc.).

**Note:** Other faults than specified in the test are acceptable, but the specified are preferable.

## 4.2.3 GET DOOR INFO

**Test Case ID:** DOORCONTROL-2-1-3

**Specification Coverage:** GetDoorInfo (ONVIF Door Control Service Specification)

**Feature Under Test:** GetDoorInfo

**WSDL Reference:** doorcontrol.wsdl

**Test Purpose:** To verify Get Door Info.

**Pre-Requisite:** Door Control Service was received from the DUT. At least one Door is configured and added to the DUT.



## Test Configuration: ONVIF Client and DUT

### Test Procedure:

1. Start an ONVIF Client.
2. Start the DUT.
3. Get a complete list of doors from the DUT (see [Annex A.1](#)).
4. ONVIF Client will invoke **GetServiceCapabilities** request to retrieve MaxLimit capability.
5. Verify the **GetServiceCapabilitiesResponse** message from the DUT.
6. ONVIF Client will invoke **GetDoorInfo** request (Token list with subset of DoorInfo.token values from the complete list of doors at step 3 with token number equal to MaxLimit) to retrieve subset of Door Information from the DUT.
7. Verify the **GetDoorInfoResponse** message from the DUT.
8. Verify that all requested DoorInfo items are in **GetDoorInfoResponse** message.
9. ONVIF Client will invoke **GetDoorInfo** request (Token = Token1, where Token1 is the first token from the complete list of doors at step 3) to retrieve Door Information for the specified token from the DUT.
10. Verify the **GetDoorInfoResponse** message from the DUT.
11. Verify that **GetDoorInfoResponse** message contains DoorInfo only for specified token.
12. Repeat steps 9-11 for all other tokens from the complete list of doors at step 3.

### Test Result:

#### PASS –

- DUT passes all assertions.

#### FAIL –

- DUT did not send **GetServiceCapabilitiesResponse** message.

**Note:** these limitations will not be used, if ONVIF Device Test Tool reuses values that were received from the DUT.

## 4.2.4 GET DOOR INFO WITH INVALID TOKEN

**Test Case ID:** DOORCONTROL-2-1-4

**Specification Coverage:** GetDoorInfo (ONVIF Door Control Service Specification)

**Feature Under Test:** GetDoorInfoList

**WSDL Reference:** doorcontrol.wsdl

**Test Purpose:** To verify Get Door Info with invalid Token.

**Pre-Requirement:** Door Control Service address was received from the DUT.

**Test Configuration:** ONVIF Client and DUT

**Test Procedure:**

1. Start an ONVIF Client.
2. Start the DUT.
3. Get complete list of doors from the DUT (see [Annex A.1](#)).
4. ONVIF Client will invoke **GetServiceCapabilities** request to retrieve MaxLimit capability.
5. Verify the **GetServiceCapabilitiesResponse** message from the DUT.
6. ONVIF Client will invoke **GetDoorInfo** request (invalid Token).
7. Verify the **GetDoorInfoResponse** message from the DUT. Check that empty list was returned.
8. ONVIF Client will invoke **GetDoorInfo** request (invalid Token, valid Token).
9. Verify the **GetDoorInfoResponse** message from the DUT. Check that list which contains Door for valid Token only was returned.

**Test Result:**

**PASS –**

- DUT passes all assertions.

**FAIL –**

- The DUT did not send valid **GetDoorInfoResponse** message.
- The DUT returned **GetDoorInfoResponse** message that contains at least two DoorInfo items with equal tokens.
- The DUT did not send valid **GetDoorInfoResponse** message.

- The DUT returned **GetDoorInfoResponse** message that contains any DoorInfo items for step 7.
- The DUT returned **GetDoorInfoResponse** message that contains any DoorInfo items other than item for valid Token or does not contains DoorInfo item for valid token step 9.
- The DUT did not return at least one Door at step 3.

**Note:** If MaxLimit less than 2, skip steps 8-9.

## 4.2.5 GET DOOR INFO LIST – LIMIT

**Test Case ID:** DOORCONTROL-2-1-6

**Specification Coverage:** GetDoorInfoList (ONVIF Door Control Service Specification)

**Feature Under Test:** GetDoorInfoList

**WSDL Reference:** doorcontrol.wsdl

**Test Purpose:** To verify Get Door Info List using Limit.

**Pre-Requisite:** Door Control Service was received from the DUT. At least one Door is configured and added to the DUT.

**Test Configuration:** ONVIF Client and DUT

### Test Procedure:

1. Start an ONVIF Client.
2. Start the DUT.
3. Get a complete list of doors from the DUT (see [Annex A.1](#))
4. ONVIF Client will invoke **GetServiceCapabilities** request to retrieve MaxLimit capability.
5. Verify the **GetServiceCapabilitiesResponse** message from the DUT.
6. ONVIF Client will invoke **GetDoorInfoList** request (Limit = 1, no StartReference) to retrieve the first item in the list of Door Information from the DUT.
7. Verify the **GetDoorInfoListResponse** message from the DUT.
8. Verify that **GetDoorInfoListResponse** message at step 7 does not contain number of items greater than 1. Verify that **GetDoorInfoListResponse** message at step 7 does not contain number of items greater than MaxLimit.

9. ONVIF Client will invoke **GetDoorInfoList** request (Limit = MaxLimit, no StartReference) to retrieve the first part of Door Information list from the DUT and is limited by MaxLimit.
10. Verify the **GetDoorInfoListResponse** message from the DUT.
11. Verify that **GetDoorInfoListResponse** message at step 10 does not contain number of items greater than MaxLimit.
12. ONVIF Client will invoke **GetDoorInfoList** request (Limit = ItemNumber, no StartReference, where ItemNumber is between 1 and minimal value of MaxLimit and the total number of doors) to retrieve Door Information sublist limited by ItemNumber from the DUT.
13. Verify the **GetDoorInfoListResponse** message from the DUT.
14. Verify that **GetDoorInfoListResponse** message at step 13 does not contain number of items greater than ItemNumber. Verify that **GetDoorInfoListResponse** message at step 13 does not contain number of items greater than MaxLimit.

**Test Result:****PASS –**

- DUT passes all assertions.

**FAIL –**

- The DUT did not send valid **GetDoorInfoListResponse** message.
- The DUT returned more DoorInfo items in **GetDoorInfoListResponse** message than it was specified in Limit parameter.
- The DUT returned more DoorInfo items in **GetDoorInfoListResponse** message than MaxLimit.
- The DUT did not return at least one Door at step 3.

**Note:** If the DUT does not return any DoorInfo on complete list of doors at step 3, skip steps 4-14, fail the test and go to the next test.

**Note:** In case MaxLimit is equal to 0, 1 will be used instead in requests.

## 4.2.6 GET DOOR INFO LIST – START REFERENCE AND LIMIT

**Test Case ID:** DOORCONTROL-2-1-7

**Specification Coverage:** GetDoorInfoList (ONVIF Door Control Service Specification)

**Feature Under Test:** GetDoorInfoList

**WSDL Reference:** doorcontrol.wsdl

**Test Purpose:** To verify Get Door Info List using StartReference and Limit.

**Pre-Requirement:** Door Control Service was received from the DUT. At least one Door is configured and added to the DUT.

**Test Configuration:** ONVIF Client and DUT

**Test Procedure:**

1. Start an ONVIF Client.
2. Start the DUT.
3. ONVIF Client will invoke **GetServiceCapabilities** request to retrieve DUT door control service capabilities.
4. Verify the **GetServiceCapabilitiesResponse** (MaxLimit) message from the DUT.
5. ONVIF Client will invoke **GetDoorInfoList** request (Limit = MaxLimit, no StartReference) to retrieve the first part of Door Information list from the DUT.
6. Verify the **GetDoorInfoListResponse** message from the DUT. Verify that **GetDoorInfoListResponse** message does not contain number of items greater than Limit. Verify that **GetDoorInfoListResponse** message does not contain number of items greater than MaxLimit.
7. If the number of DoorInfo in **GetDoorInfoListResponse** message contains NextStartReference, repeat steps 5-6 with StartReference = [current NextStartReference]. Otherwise, skip other steps and finalize getting complete door list.
8. Verify that **GetDoorInfoListResponse** messages at step 6 does not contain DoorInfo items with the same tokens values all over the list, i.e. there shall be no **GetDoorInfoListResponse** messages containing the same value for DoorInfo items token.
9. ONVIF Client will invoke **GetDoorInfoList** request (Limit = 1, no StartReference) to retrieve the first part of Door Information list from the DUT.
10. Verify the **GetDoorInfoListResponse** message from the DUT. Verify that **GetDoorInfoListResponse** message does not contain number of items greater than Limit. Verify that **GetDoorInfoListResponse** message does not contain number of items greater than MaxLimit.

11. If the number of DoorInfo in **GetDoorInfoListResponse** message contains NextStartReference, repeat steps 9-10 with StartReference = [current NextStartReference]. Otherwise, skip other steps and finalize getting complete door list.
12. Verify that **GetDoorInfoListResponse** messages at step 10 does not contain DoorInfo items with the same tokens values all over the list, i.e. there shall be no **GetDoorInfoListResponse** messages containing the same value for DoorInfo items token.
13. Verify that the total list received during steps 5-7 has the same items as the list received during steps 9-11.
14. ONVIF Client will invoke **GetDoorInfoList** request (Limit = [limit\_value], no StartReference, where limit\_value is between 1 and MaxLimit) to retrieve the first part of Door Information list from the DUT.
15. Verify the **GetDoorInfoListResponse** message from the DUT. Verify that **GetDoorInfoListResponse** message does not contain number of items greater than Limit. Verify that **GetDoorInfoListResponse** message does not contain number of items greater than MaxLimit.
16. If the number of DoorInfo in **GetDoorInfoListResponse** message contains NextStartReference, repeat steps 14-15 with StartReference = [current NextStartReference]. Otherwise, skip other steps and finalize getting complete door list.
17. Verify that **GetDoorInfoListResponse** messages at step 15 does not contain DoorInfo items with the same tokens values all over the list, i.e. there shall be no **GetDoorInfoListResponse** messages containing the same value for DoorInfo items token.
18. Verify that the total list received during steps 5-7 has the same items as the list received during steps 14-16.

**Test Result:****PASS –**

- DUT passes all assertions.

**FAIL –**

- The DUT did not send valid **GetDoorInfoListResponse** message.
- The DUT returned **GetDoorInfoListResponse** message that contains wrong item list than requested according to StartReference and Limit values.
- The DUT returned **GetDoorInfoListResponse** messages for step 6 that contains at least one pair of the same tokens for DoorInfo item all over the messages.

- The DUT returned **GetDoorInfoListResponse** messages for step 10 that contains at least one pair of the same tokens for DoorInfo item all over the messages.
- The DUT returned **GetDoorInfoListResponse** messages for step 15 that contains at least one pair of the same tokens for DoorInfo item all over the messages.
- The DUT returned more DoorInfo items in **GetDoorInfoListResponse** message than it was specified in Limit parameter.
- The DUT returned more DoorInfo items in **GetDoorInfoListResponse** message than MaxLimit.

**Note:** In case MaxLimit is equal to 0, 1 will be used instead in requests.

## 4.2.7 GET DOOR INFO LIST – NO LIMIT

**Test Case ID:** DOORCONTROL-2-1-8

**Specification Coverage:** GetDoorInfoList (ONVIF Door Control Service Specification)

**Feature Under Test:** GetDoorInfoList

**WSDL Reference:** doorcontrol.wsdl

**Test Purpose:** To verify Get Door Info List without using Limit.

**Pre-Requisite:** Door Control Service was received from the DUT. At least one Door Point is configured and added to the DUT.

**Test Configuration:** ONVIF Client and DUT

### Test Procedure:

1. Start an ONVIF Client.
2. Start the DUT.
3. ONVIF Client will invoke **GetServiceCapabilities** request to retrieve DUT door control service capabilities.
4. Verify the **GetServiceCapabilitiesResponse** (MaxLimit) message from the DUT.
5. ONVIF Client will invoke **GetDoorInfoList** request (no Limit, no StartReference) to retrieve the first part of Door Information list from the DUT.
6. Verify the **GetDoorInfoListResponse** message from the DUT. Verify that **GetDoorInfoListResponse** message does not contain number of items greater than MaxLimit.

7. If **GetDoorInfoListResponse** message contains NextStartReference, repeat steps 5-6 with StartReference = [current NextStartReference]. Otherwise, skip other steps and finalize getting the complete door list.
8. Verify that **GetDoorInfoListResponse** messages at step 6 does not contain DoorInfo items with the same tokens values all over the list, i.e. there shall be no **GetDoorInfoListResponse** messages containing the same value for DoorInfo items token.

**Test Result:****PASS –**

- DUT passes all assertions.

**FAIL –**

- The DUT did not send valid GetDoorInfoListResponse message.
- The DUT returned GetDoorInfoListResponse message that contains wrong item list than requested according to StartReference and Limit values.
- The DUT returned GetDoorInfoListResponse messages for step 6 contains at least one pair of the same tokens for DoorInfo item all over the messages.
- The DUT returned more DoorInfo items in GetDoorInfoListResponse message than MaxLimit.

## 4.2.8 GET DOOR INFO – TOO MANY ITEMS

**Test Case ID:** DOORCONTROL-2-1-10

**Specification Coverage:** GetDoorInfo (ONVIF Door Control Service Specification)

**Feature Under Test:** GetDoorInfo

**WSDL Reference:** doorcontrol.wsdl

**Test Purpose:** To verify Get Door Info in case if there are more items than MaxLimit in a request.

**Pre-Requisite:** Door Control Service was received from the DUT. At least one Door is configured and added to the DUT.

**Test Configuration:** ONVIF Client and DUT

**Test Procedure:**

1. Start an ONVIF Client.



2. Start the DUT.
3. Get a complete list of doors from the DUT (see [Annex A.1](#)).
4. ONVIF Client will invoke **GetServiceCapabilities** request to retrieve MaxLimit capability.
5. Verify the **GetServiceCapabilitiesResponse** message from the DUT.
6. If total number of doors is less than MaxLimit, skip other steps and go to the text test.
7. ONVIF Client will invoke **GetDoorInfo** request (Token list with subset of DoorInfo.token values from a complete list of doors at step 3 with token number greater than MaxLimit) to retrieve a subset of Door Information from the DUT.
8. The DUT will generate SOAP 1.2 fault message (**InvalidArgs/TooManyItems**).

**Test Result:****PASS –**

- DUT passes all assertions.

**FAIL –**

- The DUT did not send SOAP 1.2 fault message.
- The DUT sent incorrect SOAP 1.2 fault message (fault code, namespace, etc.).
- The DUT did not send valid GetServiceCapabilitiesResponse.
- The DUT did not return at least one Door at step 3.

**Note:** If the DUT does not return any DoorInfo on complete list of doors at step 3, skip steps 4-8, fail test and go to the next test.

## 4.3 Door Control

### 4.3.1 ACCESS DOOR WITH INVALID TOKEN

**Test Case ID:** DOORCONTROL-3-1-10

**Specification Coverage:** AccessDoor (ONVIF Door Control Service Specification)

**Feature Under Test:** AccessDoor

**WSDL Reference:** doorcontrol.wsdl

**Test Purpose:** To verify Access Door with invalid Token.

**Pre-Requisite:** Door Control Service address was received from the DUT.

**Test Configuration:** ONVIF Client and DUT

**Test Procedure:**

1. Start an ONVIF Client.
2. Start the DUT.
3. ONVIF Client will invoke **AccessDoor** request (invalid Token).
4. The DUT will generate SOAP 1.2 fault message (**InvalidArgVal/NotFound**).

**Test Result:**

**PASS –**

- DUT passes all assertions.

**FAIL –**

- The DUT did not send SOAP 1.2 fault message.
- The DUT sent incorrect SOAP 1.2 fault message (fault code, namespace, etc.).

**Note:** Other faults than specified in the test are acceptable, but the specified are preferable.

## 4.3.2 BLOCK DOOR WITH INVALID TOKEN

**Test Case ID:** DOORCONTROL-3-1-11

**Specification Coverage:** BlockDoor (ONVIF Door Control Service Specification)

**Feature Under Test:** BlockDoor

**WSDL Reference:** doorcontrol.wsdl

**Test Purpose:** To verify Block Door with invalid Token.

**Pre-Requisite:** Door Control Service address was received from the DUT.

**Test Configuration:** ONVIF Client and DUT

**Test Procedure:**

1. Start an ONVIF Client.
2. Start the DUT.
3. ONVIF Client will invoke **BlockDoor** request (invalid Token).
4. The DUT will generate SOAP 1.2 fault message (**InvalidArgVal/NotFound**).

**Test Result:****PASS –**

- DUT passes all assertions.

**FAIL –**

- The DUT did not send SOAP 1.2 fault message.
- The DUT sent incorrect SOAP 1.2 fault message (fault code, namespace, etc.).

**Note:** Other faults than specified in the test are acceptable, but the specified are preferable.

### 4.3.3 DOUBLE LOCK DOOR WITH INVALID TOKEN

**Test Case ID:** DOORCONTROL-3-1-12

**Specification Coverage:** DoubleLockDoor (ONVIF Door Control Service Specification)

**Feature Under Test:** DoubleLockDoor

**WSDL Reference:** doorcontrol.wsdl

**Test Purpose:** To verify Double Lock Door with invalid Token.

**Pre-Requisite:** Door Control Service address was received from the DUT.

**Test Configuration:** ONVIF Client and DUT

**Test Procedure:**

1. Start an ONVIF Client.
2. Start the DUT.
3. ONVIF Client will invoke **DoubleLockDoor** request (invalid Token).
4. The DUT will generate SOAP 1.2 fault message (**InvalidArgVal/NotFound**).

**Test Result:**

**PASS –**

- DUT passes all assertions.

**FAIL –**

- The DUT did not send SOAP 1.2 fault message.
- The DUT sent incorrect SOAP 1.2 fault message (fault code, namespace, etc.).

**Note:** Other faults than specified in the test are acceptable, but the specified are preferable.

## 4.3.4 LOCK DOOR WITH INVALID TOKEN

**Test Case ID:** DOORCONTROL-3-1-13

**Specification Coverage:** LockDoor (ONVIF Door Control Service Specification)

**Feature Under Test:** LockDoor

**WSDL Reference:** doorcontrol.wsdl

**Test Purpose:** To verify Lock Door with invalid Token.

**Pre-Requisite:** Door Control Service address was received from the DUT.

**Test Configuration:** ONVIF Client and DUT

**Test Procedure:**

1. Start an ONVIF Client.
2. Start the DUT.
3. ONVIF Client will invoke **LockDoor** request (invalid Token).
4. The DUT will generate SOAP 1.2 fault message (**InvalidArgVal/NotFound**).

**Test Result:****PASS –**

- DUT passes all assertions.

**FAIL –**

- The DUT did not send SOAP 1.2 fault message.
- The DUT sent incorrect SOAP 1.2 fault message (fault code, namespace, etc.).

**Note:** Other faults than specified in the test are acceptable, but the specified are preferable.

## 4.3.5 UNLOCK DOOR WITH INVALID TOKEN

**Test Case ID:** DOORCONTROL-3-1-14

**Specification Coverage:** UnlockDoor (ONVIF Door Control Service Specification)

**Feature Under Test:** UnlockDoor

**WSDL Reference:** doorcontrol.wsdl

**Test Purpose:** To verify Unlock Door with invalid Token.

**Pre-Requirement:** Door Control Service address was received from the DUT.

**Test Configuration:** ONVIF Client and DUT

**Test Procedure:**

1. Start an ONVIF Client.
2. Start the DUT.
3. ONVIF Client will invoke **UnlockDoor** request (invalid Token).
4. The DUT will generate SOAP 1.2 fault message (**InvalidArgVal/NotFound**).

**Test Result:**

**PASS –**

- DUT passes all assertions.

**FAIL –**

- The DUT did not send SOAP 1.2 fault message.
- The DUT sent incorrect SOAP 1.2 fault message (fault code, namespace, etc.).

**Note:** Other faults than specified in the test are acceptable, but the specified are preferable.

## 4.3.6 LOCK DOWN DOOR WITH INVALID TOKEN

**Test Case ID:** DOORCONTROL-3-1-15

**Specification Coverage:** LockDownDoor (ONVIF Door Control Service Specification)

**Feature Under Test:** LockDownDoor

**WSDL Reference:** doorcontrol.wsdl

**Test Purpose:** To verify Lock Down Door with invalid Token.

**Pre-Requirement:** Door Control Service address was received from the DUT.

**Test Configuration:** ONVIF Client and DUT

**Test Procedure:**

1. Start an ONVIF Client.
2. Start the DUT.
3. ONVIF Client will invoke **LockDownDoor** request (invalid Token).
4. The DUT will generate SOAP 1.2 fault message (**InvalidArgVal/NotFound**).

**Test Result:**

**PASS –**

- DUT passes all assertions.

**FAIL –**

- The DUT did not send SOAP 1.2 fault message.
- The DUT sent incorrect SOAP 1.2 fault message (fault code, namespace, etc.).

**Note:** Other faults than specified in the test are acceptable, but the specified are preferable.

## 4.3.7 LOCK DOWN RELEASE DOOR WITH INVALID TOKEN

**Test Case ID:** DOORCONTROL-3-1-16

**Specification Coverage:** LockDownReleaseDoor (ONVIF Door Control Service Specification)

**Feature Under Test:** LockDownReleaseDoor

**WSDL Reference:** doorcontrol.wsdl

**Test Purpose:** To verify Lock Down Release Door with invalid Token.

**Pre-Requirement:** Door Control Service address was received from the DUT. **Test Configuration:** ONVIF Client and DUT

**Test Configuration:** ONVIF Client and DUT

**Test Procedure:**

1. Start an ONVIF Client.
2. Start the DUT.
3. ONVIF Client will invoke **LockDownReleaseDoor** request (invalid Token).
4. The DUT will generate SOAP 1.2 fault message (**InvalidArgVal/NotFound**).

**Test Result:**

**PASS –**

- DUT passes all assertions.

**FAIL –**

- The DUT did not send SOAP 1.2 fault message.
- The DUT sent incorrect SOAP 1.2 fault message (fault code, namespace, etc.).

**Note:** Other faults than specified in the test are acceptable, but the specified are preferable.

## 4.3.8 LOCK OPEN DOOR WITH INVALID TOKEN

**Test Case ID:** DOORCONTROL-3-1-17

**Specification Coverage:** LockOpenDoor (ONVIF Door Control Service Specification)

**Feature Under Test:** LockOpenDoor

**WSDL Reference:** doorcontrol.wsdl

**Test Purpose:** To verify Lock Open Door with invalid Token.

**Pre-Requisite:** Door Control Service address was received from the DUT.

**Test Configuration:** ONVIF Client and DUT

**Test Procedure:**

1. Start an ONVIF Client.
2. Start the DUT.

3. ONVIF Client will invoke **LockOpenDoor** request (invalid Token).
4. The DUT will generate SOAP 1.2 fault message (**InvalidArgVal/NotFound**).

**Test Result:****PASS –**

- DUT passes all assertions.

**FAIL –**

- The DUT did not send SOAP 1.2 fault message.
- The DUT sent incorrect SOAP 1.2 fault message (fault code, namespace, etc.).

**Note:** Other faults than specified in the test are acceptable, but the specified are preferable.

## 4.3.9 LOCK OPEN RELEASE DOOR WITH INVALID TOKEN

**Test Case ID:** DOORCONTROL-3-1-18

**Specification Coverage:** LockOpenReleaseDoor (ONVIF Door Control Service Specification)

**Feature Under Test:** LockOpenReleaseDoor

**WSDL Reference:** doorcontrol.wsdl

**Test Purpose:** To verify Lock Open Release Door with invalid Token.

**Pre-Requisite:** Door Control Service address was received from the DUT.

**Test Configuration:** ONVIF Client and DUT

**Test Procedure:**

1. Start an ONVIF Client.
2. Start the DUT.
3. ONVIF Client will invoke **LockOpenReleaseDoor** request (invalid Token).
4. The DUT will generate SOAP 1.2 fault message (**InvalidArgVal/NotFound**).

**Test Result:****PASS –**

- DUT passes all assertions.



**FAIL –**

- The DUT did not send SOAP 1.2 fault message.
- The DUT sent incorrect SOAP 1.2 fault message (fault code, namespace, etc.).

**Note:** Other faults than specified in the test are acceptable, but the specified are preferable.

## 4.3.10 ACCESS DOOR – COMMAND NOT SUPPORTED

**Test Case ID:** DOORCONTROL-3-1-19

**Specification Coverage:** AccessDoor (ONVIF Door Control Service Specification)

**Feature Under Test:** AccessDoor

**WSDL Reference:** doorcontrol.wsdl

**Test Purpose:** To verify that fault is returned for Access Door in case Door does not support it.

**Pre-Requisite:** Door Control Service was received from the DUT. At least one Door is configured and added to the DUT.

**Test Configuration:** ONVIF Client and DUT

**Test Procedure:**

1. Start an ONVIF Client.
2. Start the DUT.
3. Get a complete list of doors from the DUT (see [Annex A.1](#)).
4. If Door with Token1 (Token1 is the first DoorInfo.token from the complete list of doors at step 3) has DoorInfo.Capabilities.Access equal to true, then skip steps 5-6 and go to the step 7.
5. ONVIF Client will invoke **AccessDoor** request (Token = "Token1", where Token1 is the first DoorInfo.token from the complete list of doors at step 3) to try changing door state.
6. The DUT will generate SOAP 1.2 fault message.
7. Repeat steps 4-6 for all other tokens from the complete list of doors at step 3.

**Test Result:****PASS –**

- DUT passes all assertions.

**FAIL –**

- The DUT did not send SOAP 1.2 fault message.
- The DUT did not return at least one Door at step 3.

**Note:** If the DUT does not return any door for step 3, skip steps 4-7, fail the test and go to the next test.

### 4.3.11 BLOCK DOOR – COMMAND NOT SUPPORTED

**Test Case ID:** DOORCONTROL-3-1-20

**Specification Coverage:** BlockDoor (ONVIF Door Control Service Specification)

**Feature Under Test:** BlockDoor

**WSDL Reference:** doorcontrol.wsdl

**Test Purpose:** To verify that fault is returned for Block Door in case Door does not support it.

**Pre-Requisite:** Door Control Service was received from the DUT. At least one Door is configured and added to the DUT.

**Test Configuration:** ONVIF Client and DUT

**Test Procedure:**

1. Start an ONVIF Client.
2. Start the DUT.
3. Get a complete list of doors from the DUT (see [Annex A.1](#)).
4. If Door with Token1 (Token1 is the first DoorInfo.token from the complete list of doors at step 3) has DoorInfo.Capabilities.Block equal to true, then skip steps 5-6 and go to the step 7.
5. ONVIF Client will invoke **BlockDoor** request (Token = "Token1", where Token1 is the first DoorInfo.token from the complete list of doors at step 3) to try changing door state.
6. The DUT will generate SOAP 1.2 fault message.
7. Repeat steps 5-7 for all other tokens from the complete list of doors at step 3.

**Test Result:**

**PASS –**

- DUT passes all assertions.

**FAIL –**

- The DUT did not send SOAP 1.2 fault message.
- The DUT did not return at least one Door at step 3.

**Note:** If the DUT does not return any door for step 3, skip steps 4-7, fail the test and go to the next test.

## 4.3.12 DOUBLE LOCK DOOR – COMMAND NOT SUPPORTED

**Test Case ID:** DOORCONTROL-3-1-21

**Specification Coverage:** DoubleLockDoor (ONVIF Door Control Service Specification)

**Feature Under Test:** DoubleLockDoor

**WSDL Reference:** doorcontrol.wsdl

**Test Purpose:** To verify that fault is returned for Double Lock Door in case Door does not support it.

**Pre-Requisite:** Door Control Service was received from the DUT. At least one Door is configured and added to the DUT.

**Test Configuration:** ONVIF Client and DUT

**Test Procedure:**

1. Start an ONVIF Client.
2. Start the DUT.
3. Get a complete list of doors from the DUT (see [Annex A.1](#)).
4. If Door with Token1 (Token1 is the first DoorInfo.token from the complete list of doors at step 3) has DoorInfo.Capabilities.DoubleLock equal to true, then skip steps 5-6 and go to the step 7.
5. ONVIF Client will invoke **DoubleLockDoor** request (Token = "Token1", where Token1 is the first DoorInfo.token from the complete list of doors at step 3) to try changing door state.
6. The DUT will generate SOAP 1.2 fault message.
7. Repeat steps 5-7 for all other tokens from complete list of doors at step 3.

**Test Result:****PASS –**

- DUT passes all assertions.

**FAIL –**

- The DUT did not send SOAP 1.2 fault message.
- The DUT did not return at least one Door at step 3.

**Note:** If the DUT does not return any door for step 3, skip steps 4-7, fail the test and go to the next test.

### 4.3.13 LOCK DOOR – COMMAND NOT SUPPORTED

**Test Case ID:** DOORCONTROL-3-1-22

**Specification Coverage:** LockDoor (ONVIF Door Control Service Specification)

**Feature Under Test:** LockDoor

**WSDL Reference:** doorcontrol.wsdl

**Test Purpose:** To verify that fault is returned for Lock Door in case Door does not support it.

**Pre-Requisite:** Door Control Service was received from the DUT. At least one Door configured and added to the DUT.

**Test Configuration:** ONVIF Client and DUT

**Test Procedure:**

1. Start an ONVIF Client.
2. Start the DUT.
3. Get a complete list of doors from the DUT (see [Annex A.1](#)).
4. If Door with Token1 (Token1 is the first DoorInfo.token from the complete list of doors at step 3) has DoorInfo.Capabilities.Lock equal to true, then skip steps 5-6 and go to the step 7.
5. ONVIF Client will invoke **LockDoor** request (Token = "Token1", where Token1 is the first DoorInfo.token from the complete list of doors at step 3) to try changing door state.
6. The DUT will generate SOAP 1.2 fault message.

- Repeat steps 5-7 for all other tokens from the complete list of doors at step 3.

**Test Result:****PASS –**

- DUT passes all assertions.

**FAIL –**

- The DUT did not send SOAP 1.2 fault message.
- The DUT did not return at least one Door at step 3.

**Note:** If the DUT does not return any door for step 3, skip steps 4-7, fail the test and go to the next test.

## 4.3.14 UNLOCK DOOR – COMMAND NOT SUPPORTED

**Test Case ID:** DOORCONTROL-3-1-23

**Specification Coverage:** UnlockDoor (ONVIF Door Control Service Specification)

**Feature Under Test:** UnlockDoor

**WSDL Reference:** doorcontrol.wsdl

**Test Purpose:** To verify that fault is returned for Unlock Door in case Door does not support it.

**Pre-Requirement:** Door Control Service was received from the DUT. At least one Door is configured and added to the DUT.

**Test Configuration:** ONVIF Client and DUT

**Test Procedure:**

- Start an ONVIF Client.
- Start the DUT.
- Get a complete list of doors from the DUT (see [Annex A.1](#)).
- If Door with Token1 (Token1 is the first DoorInfo.token from the complete list of doors at step 3) has DoorInfo.Capabilities.Unlock equal to true, then skip steps 5-6 and go to the step 7.
- ONVIF Client will invoke **UnlockDoor** request (Token = "Token1", where Token1 is the first DoorInfo.token from the complete list of doors at step 3) to try changing door state.

6. The DUT will generate SOAP 1.2 fault message.
7. Repeat steps 5-7 for all other tokens from the complete list of doors at step 3.

**Test Result:****PASS –**

- DUT passes all assertions.

**FAIL –**

- The DUT did not send SOAP 1.2 fault message.
- The DUT did not return at least one Door at step 3.

**Note:** If the DUT does not return any door for step 3, skip steps 4-7, fail the test and go to the next test.

### 4.3.15 LOCK DOWN DOOR – COMMAND NOT SUPPORTED

**Test Case ID:** DOORCONTROL-3-1-24

**Specification Coverage:** LockDownDoor (ONVIF Door Control Service Specification)

**Feature Under Test:** LockDownDoor

**WSDL Reference:** doorcontrol.wsdl

**Test Purpose:** To verify that fault is returned for Lock Down Door in case Door does not support it.

**Pre-Requisite:** Door Control Service was received from the DUT. At least one Door is configured and added to the DUT.

**Test Configuration:** ONVIF Client and DUT

**Test Procedure:**

1. Start an ONVIF Client.
2. Start the DUT.
3. Get a complete list of doors from the DUT (see [Annex A.1](#)).
4. If Door with Token1 (Token1 is the first DoorInfo.token from the complete list of doors at step 3) has DoorInfo.Capabilities.LockDown equal to true, then skip steps 5-6 and go to the step 7.

5. ONVIF Client will invoke **LockDownDoor** request (Token = “Token1”, where Token1 is the first DoorInfo.token from the complete list of doors at step 3) to try changing door state.
6. The DUT will generate SOAP 1.2 fault message.
7. Repeat steps 5-7 for all other tokens from the complete list of doors at step 3.

**Test Result:****PASS –**

- DUT passes all assertions.

**FAIL –**

- The DUT did not send SOAP 1.2 fault message.
- The DUT did not return at least one Door at step 3.

**Note:** If the DUT does not return any door for step 3, skip steps 4-7, fail the test and go to the next test.

## 4.3.16 LOCK DOWN RELEASE DOOR – COMMAND NOT SUPPORTED

**Test Case ID:** DOORCONTROL-3-1-25

**Specification Coverage:** LockDownReleaseDoor (ONVIF Door Control Service Specification)

**Feature Under Test:** LockDownReleaseDoor

**WSDL Reference:** doorcontrol.wsdl

**Test Purpose:** To verify that fault is returned for Lock Down Release Door in case Door does not support it.

**Pre-Requsite:** Door Control Service was received from the DUT. At least one Door is configured and added to the DUT.

**Test Configuration:** ONVIF Client and DUT

**Test Procedure:**

1. Start an ONVIF Client.
2. Start the DUT.

3. Get a complete list of doors from the DUT (see [Annex A.1](#)).
4. If Door with Token1 (Token1 is the first DoorInfo.token from the complete list of doors at step 3) has DoorInfo.Capabilities.LockDown equal to true, then skip steps 5-6 and go to the step 7.
5. ONVIF Client will invoke **LockDownReleaseDoor** request (Token = "Token1", where Token1 is the first DoorInfo.token from the complete list of doors at step 3) to try changing door state.
6. The DUT will generate SOAP 1.2 fault message.
7. Repeat steps 5-7 for all other tokens from the complete list of doors at step 3.

**Test Result:****PASS –**

- DUT passes all assertions.

**FAIL –**

- The DUT did not send SOAP 1.2 fault message.
- The DUT did not return at least one Door at step 3.

**Note:** If the DUT does not return any door for step 3, skip steps 4-7, fail the test and go to the next test.

## 4.3.17 LOCK OPEN DOOR – COMMAND NOT SUPPORTED

**Test Case ID:** DOORCONTROL-3-1-26

**Specification Coverage:** LockOpenDoor (ONVIF Door Control Service Specification)

**Feature Under Test:** LockOpenDoor

**WSDL Reference:** doorcontrol.wsdl

**Test Purpose:** To verify that fault is returned for Lock Open Door in case Door does not support it.

**Pre-Requisite:** Door Control Service was received from the DUT. At least one Door is configured and added to the DUT.

**Test Configuration:** ONVIF Client and DUT

**Test Procedure:**



1. Start an ONVIF Client.
2. Start the DUT.
3. Get a complete list of doors from the DUT (see [Annex A.1](#)).
4. If Door with Token1 (Token1 is the first DoorInfo.token from the complete list of doors at step 3) has DoorInfo.Capabilities.LockOpen equal to true, then skip steps 5-6 and go to the step 7.
5. ONVIF Client will invoke **LockOpenDoor** request (Token = "Token1", where Token1 is the first DoorInfo.token from the complete list of doors at step 3) to try changing door state.
6. The DUT will generate SOAP 1.2 fault message.
7. Repeat steps 5-7 for all other tokens from the complete list of doors at step 3.

**Test Result:****PASS –**

- DUT passes all assertions.

**FAIL –**

- The DUT did not send SOAP 1.2 fault message.
- The DUT did not return at least one Door at step 3.

**Note:** If the DUT does not return any door for step 3, skip steps 4-7, fail the test and go to the next test.

## 4.3.18 LOCK OPEN RELEASE DOOR – COMMAND NOT SUPPORTED

**Test Case ID:** DOORCONTROL-3-1-27

**Specification Coverage:** LockOpenReleaseDoor (ONVIF Door Control Service Specification)

**Feature Under Test:** LockOpenReleaseDoor

**WSDL Reference:** doorcontrol.wsdl

**Test Purpose:** To verify that fault is returned for Lock Open Release Door in case Door does not support it.

**Pre-Requisite:** Door Control Service was received from the DUT. At least one Door is configured and added to the DUT.

**Test Configuration:** ONVIF Client and DUT

**Test Procedure:**

1. Start an ONVIF Client.
2. Start the DUT.
3. Get a complete list of doors from the DUT (see [Annex A.1](#)).
4. If Door with Token1 (Token1 is the first DoorInfo.token from the complete list of doors at step 3) has DoorInfo.Capabilities.LockOpen equal to true, then skip steps 5-6 and go to the step 7.
5. ONVIF Client will invoke **LockOpenReleaseDoor** request (Token = "Token1", where Token1 is the first DoorInfo.token from complete list of doors at step 3) to try changing door state.
6. The DUT will generate SOAP 1.2 fault message.
7. Repeat steps 5-7 for all other tokens from the complete list of doors at step 3.

**Test Result:**

**PASS –**

- DUT passes all assertions.

**FAIL –**

- The DUT did not send SOAP 1.2 fault message.
- The DUT did not return at least one Door at step 3.

**Note:** If the DUT does not return any door for step 3, skip steps 4-7, fail the test and go to the next test.

## 4.3.19 ACCESS DOOR

**Test Case ID:** DOORCONTROL-3-1-28

**Specification Coverage:** AccessDoor (ONVIF Door Control Service Specification), tns1:Door/State/DoorMode (ONVIF Door Control Service Specification)

**Feature Under Test:** AccessDoor

**WSDL Reference:** doorcontrol.wsdl

**Test Purpose:** To verify that Access Door is accepted. To verify Door state change after Access Door command. To verify tns1:Door/State/DoorMode property events.

**Pre-Requisite:** Door Control Service was received from the DUT. At least one Door with Access capability is configured and added to the DUT. The doors are closed and there are no schedules.  
Test Configuration: ONVIF Client and DUT

**Test Configuration:** ONVIF Client and DUT

**Test Procedure:**

1. Start an ONVIF Client.
2. Start the DUT.
3. Get a complete list of doors from the DUT (see [Annex A.1](#)).
4. ONVIF Client selects one door from the complete list of doors at step 3 with DoorInfo.Capabilities.Access equal to true and DoorInfo.Capabilities.Lock equal to true. If there is no Door with DoorInfo.Capabilities.Access equal to true, fail the test and skip other steps. If there is no Door with DoorInfo.Capabilities.Access equal to true and DoorInfo.Capabilities.Lock equal to true, then ONVIF Client executes [Annex A.4](#) to start user interaction process, and then goes to step 6.
5. ONVIF Client will execute [Annex A.5](#) to switch the selected door into Locked state.
6. ONVIF Client will invoke **CreatePullPointSubscription** request with tns1:Door/State/DoorMode Topic as Filter and an InitialTerminationTime of timeout1.
7. Verify that the DUT sends a **CreatePullPointSubscriptionResponse** message.
8. Execute [Annex A.3](#) to catch Initialized event for selected door. State of the Door received in [Annex A.3](#) will be assumed as initial State of this Door.
9. ONVIF Client will invoke **AccessDoor** request (Token = [selected Door token]) to change door state.
10. Verify the **AccessDoorResponse** message from the DUT.
11. ONVIF Client will invoke **PullMessages** command with a PullMessagesTimeout of 20s and a MessageLimit of 1.
12. Verify that the DUT sends a **PullMessagesResponse** that contains NotificationMessages. Repeat step 11 until Notification messages with PropertyOperation = "Changed" contains

- Source.SimpleItem item with Name = "DoorToken" and Value is equal to selected Door Token with State = "Accessed" is received (Operation Delay option from ONVIF Device Test Tool will be used).
13. Check that all Notification messages with PropertyOperation = "Changed" contain Source.SimpleItem item with Name = "DoorToken" and Value equal to selected Door Token.
  14. Check that all Notification messages with PropertyOperation = "Changed" have TopicExpression equal to tns1:Door/State/DoorMode.
  15. Check that received Notification message with PropertyOperation = "Changed" contains Data.SimpleItem item with Name = «State» and Value equal to "Accessed". Check that other Notification messages contain Data.SimpleItem item with Name = «State» and Value with tdc:DoorMode type.
  16. Verify received Notification messages (correct value for UTC time, TopicExpression and wsnt:Message).
  17. ONVIF Client will invoke **PullMessages** command with a PullMessagesTimeout of 20s and a MessageLimit of 1.
  18. Verify that the DUT sends a **PullMessagesResponse** that contains NotificationMessages. Repeat step 17 until timeout expires (Operation Delay option from ONVIF Device Test Tool will be used).
  19. Check that all Notification messages with PropertyOperation = "Changed" contain Source.SimpleItem item with Name = "DoorToken" and Value equal to selected Door Token.
  20. Check that all Notification messages with PropertyOperation = "Changed" have TopicExpression equal to tns1:Door/State/DoorMode.
  21. Check that the last Notification message with PropertyOperation = "Changed" contains Data.SimpleItem item with Name = «State» and Value equal to initial Door state from step 8. Check that other Notification messages contain Data.SimpleItem item with Name = «State» and Value with tdc:DoorMode type.
  22. Verify received Notification messages (correct value for UTC time, TopicExpression and wsnt:Message).

**Test Result:****PASS –**

- DUT passes all assertions.

**FAIL –**

- The DUT did not send valid **AccessDoorResponse** message.
- The DUT did not send **CreatePullPointSubscriptionResponse** message.
- The DUT did not return at least one Door at step 3.
- The DUT sent an invalid Notification messages with PropertyOperation = "Changed" (correct value for UTC time, TopicExpression and wsnt:Message, Topic = "tns1:Door/State/DoorMode", contains Source.SimpleItem item with Name = "DoorToken" and Value equal to selected Door Token, contains Data.SimpleItem item with Name = «State» and Value with type equal to tdc:DoorMode) at steps 12 and 18.
- The DUT did not send Notification message with PropertyOperation = "Changed" with State value "Accessed" at step 12.
- The DUT sent the last Notification message with PropertyOperation = "Changed" at step 18 with State value other than initial State at step 8.

**Note:** If the DUT did not return any door for step 3, skip steps 4-22, fail the test and go to the next test.

**Note:** If the DUT sends SOAP fault to AccessDoor request then the ONVIF Client deletes Subscription Manager, starts user interaction process (see Annex A.4), and then runs the test from step 6.

**Note:** If in the Annex A.5 the DUT sends SOAP fault to request to change door mode, then the ONVIF Client starts user interaction process (see Annex A.4), and then runs the test from step 6.

**Note:** The Subscription Manager has to be deleted at the end of the test either by calling unsubscribe or through a timeout.

**Note:** The Renew has to be used for renew subscription during test, if InitialTerminationTime expires.

**Note:** If DUT cannot accept the set value to Timeout or MessageLimit, ONVIF Client retries to send the PullMessage message with Timeout and MessageLimit which is contained in PullMessagesFaultResponse.

**Note:** If DUT cannot accept the set value to a TerminationTime, ONVIF Client retries to send the Renew request MinimumTime value which is contained in UnacceptableTerminationTimeFault.

**Note:** timeout1 will be taken from Subscription Timeout field of ONVIF Device Test Tool.

## 4.3.20 BLOCK DOOR

**Test Case ID:** DOORCONTROL-3-1-29

**Specification Coverage:** BlockDoor (ONVIF Door Control Service Specification), tns1:Door/State/DoorMode (ONVIF Door Control Service Specification)

**Feature Under Test:** BlockDoor

**WSDL Reference:** doorcontrol.wsdl

**Test Purpose:** To verify that Block Door is accepted. To verify Door state change after Block Door command. To verify tns1:Door/State/DoorMode property events.

**Pre-Requisite:** Door Control Service was received from the DUT. At least one Door with Block capability is configured and added to the DUT. The doors are closed and there are no schedules.

**Test Configuration:** ONVIF Client and DUT

**Test Procedure:**

1. Start an ONVIF Client.
2. Start the DUT.
3. Get a complete list of doors from the DUT (see [Annex A.1](#)).
4. ONVIF Client selects one door from the complete list of doors at step 3 with DoorInfo.Capabilities.Block equal to true and DoorInfo.Capabilities.Locked equal to true. If there is no Door with DoorInfo.Capabilities.Block equal to true, fail the test and skip other steps. If there is no Door with DoorInfo.Capabilities.Block equal to true and DoorInfo.Capabilities.Lock equal to true, then ONVIF Client executes [Annex A.4](#) to start user interaction process, and then goes to step 6.
5. ONVIF Client will execute [Annex A.5](#) to switch the selected door into Locked state.
6. ONVIF Client will invoke **CreatePullPointSubscription** request with tns1:Door/State/DoorMode Topic as Filter and an InitialTerminationTime of timeout1.
7. Verify that the DUT sends a **CreatePullPointSubscriptionResponse** message.
8. Execute [Annex A.3](#) to catch Initialized event for selected door.
9. ONVIF Client will invoke **BlockDoor** request (Token = [selected Door token]) to change door state.
10. Verify the **BlockDoorResponse** message from the DUT.
11. ONVIF Client will invoke **PullMessages** command with a PullMessagesTimeout of 20s and a MessageLimit of 1.

12. Verify that the DUT sends a **PullMessagesResponse** that contains NotificationMessages. Repeat step 11 until timeout expires (Operation Delay option from ONVIF Device Test Tool will be used).
13. Check that all Notification messages with PropertyOperation = "Changed" contain Source.SimpleItem item with Name = "DoorToken" and Value equal to selected Door Token.
14. Check that all Notification messages with PropertyOperation = "Changed" have TopicExpression equal to tns1:Door/State/DoorMode.
15. Verify that the last Notification message with PropertyOperation = "Changed" contains Data.SimpleItem item with Name = «State» and Value equal to "Blocked". Check that other Notification messages contain Data.SimpleItem item with Name = «State» and Value with tdc:DoorMode type.
16. Verify received Notification messages (correct value for UTC time, TopicExpression and wsnt:Message).

**Test Result:****PASS –**

- DUT passes all assertions.

**FAIL –**

- The DUT did not send valid BlockDoorResponse message.
- The DUT did not send CreatePullPointSubscriptionResponse message.
- The DUT did not return at least one Door at step 3.
- The DUT sent an invalid Notification messages with PropertyOperation = "Changed" (correct value for UTC time, TopicExpression and wsnt:Message, Topic = "tns1:Door/State/DoorMode", contains Source.SimpleItem item with Name = "DoorToken" and Value equal to selected Door Token, contains Data.SimpleItem item with Name = «State» and Value with type equal to tdc:DoorMode) at step 12.
- The DUT sent the last Notification message with PropertyOperation = "Changed" with State value other than "Blocked" at step 12.

**Note:** If the DUT does not return any door for step 3, skip steps 4-16, fail the test and go to the next test.

**Note:** If the DUT sends SOAP fault to BlockDoor request then the ONVIF Client deletes Subscription Manager, starts user interaction process (see Annex A.4), and then runs the test from step 6.

**Note:** If in the [Annex A.1](#) the DUT sends SOAP fault to request to change door mode, then the ONVIF Client starts user interaction process (see [Annex A.4](#)), and then runs the test from step 6.

**Note:** The Subscription Manager has to be deleted at the end of the test either by calling unsubscribe or through a timeout.

**Note:** The Renew has to be used for renew subscription during test, if InitialTerminationTime expires.

**Note:** If DUT cannot accept the set value to Timeout or MessageLimit, ONVIF Client retries to send the PullMessage message with Timeout and MessageLimit which is contained in PullMessagesFaultResponse.

**Note:** If DUT cannot accept the set value to a TerminationTime, ONVIF Client retries to send the Renew request MinimumTime value which is contained in UnacceptableTerminationTimeFault.

**Note:** timeout1 will be taken from Subscription Timeout field of ONVIF Device Test Tool.

## 4.3.21 DOUBLE LOCK DOOR

**Test Case ID:** DOORCONTROL-3-1-30

**Specification Coverage:** DoubleLockDoor (ONVIF Door Control Service Specification)

**Feature Under Test:** DoubleLockDoor

**WSDL Reference:** doorcontrol.wsdl

**Test Purpose:** To verify that Double Lock Door is accepted. To verify Door state change after Double Lock Door command. To verify tns1:Door/State/DoorMode property events.

**Pre-Requisite:** Door Control Service was received from the DUT. At least one Door with Double Lock capability is configured and added to the DUT. The doors are closed and there are no schedules.

**Test Configuration:** ONVIF Client and DUT

**Test Procedure:**

1. Start an ONVIF Client.
2. Start the DUT.
3. Get complete list of doors from the DUT (see [Annex A.1](#)).
4. ONVIF Client selects one door from the complete list of doors at step 3 with DoorInfo.Capabilities.DoubleLock equal to true and DoorInfo.Capabilities.Locked equal to



- true. If there is no Door with DoorInfo.Capabilities.DoubleLock equal to true, fail the test and skip other steps. If there is no Door with DoorInfo.Capabilities.DoubleLock equal to true and DoorInfo.Capabilities.Lock equal to true, then ONVIF Client executes [Annex A.4](#) to start user interaction process and then goes to step 6.
5. ONVIF Client will execute [Annex A.5](#) to switch the selected door into Locked state.
  6. ONVIF Client will invoke **CreatePullPointSubscription** request with tns1:Door/State/DoorMode Topic as Filter and an InitialTerminationTime of timeout1.
  7. Verify that the DUT sends a **CreatePullPointSubscriptionResponse** message.
  8. Execute [Annex A.3](#) to catch Initialized event for selected door.
  9. ONVIF Client will invoke **DoubleLockDoor** request (Token = [selected Door token]) to change door state.
  10. Verify the **DoubleLockDoorResponse** message from the DUT.
  11. ONVIF Client will invoke **PullMessages** command with a PullMessagesTimeout of 20s and a MessageLimit of 1.
  12. Verify that the DUT sends a **PullMessagesResponse** that contains NotificationMessages. Repeat step 11 until timeout expires (Operation Delay option from ONVIF Device Test Tool will be used).
  13. Check that all Notification messages with PropertyOperation = "Changed" contain Source.SimpleItem item with Name = "DoorToken" and Value equal to selected Door Token.
  14. Check that all Notification messages with PropertyOperation = "Changed" have TopicExpression equal to tns1:Door/State/DoorMode.
  15. Verify that the last Notification message with PropertyOperation = "Changed" contains Data.SimpleItem item with Name = «State» and Value equal to "DoubleLocked". Check that other Notification messages contain Data.SimpleItem item with Name = «State» and Value with tdc:DoorMode type.
  16. Verify received Notification messages (correct value for UTC time, TopicExpression and wsnt:Message).

**Test Result:****PASS –**

- DUT passes all assertions.

**FAIL –**

- The DUT did not send valid DoubleLockDoorResponse message.
- The DUT did not send CreatePullPointSubscriptionResponse message.
- The DUT did not return at least one Door at step 3.
- The DUT sent an invalid Notification messages with PropertyOperation = "Changed" (correct value for UTC time, TopicExpression and wsnt:Message, Topic = "tns1:Door/State/DoorMode", contains Source.SimpleItem item with Name = "DoorToken" and Value equal to selected Door Token, contains Data.SimpleItem item with Name = «State» and Value with type equal to tdc:DoorMode) at step 11.
- The DUT sent the last Notification message with PropertyOperation = "Changed" with State value other than "DoubleLocked" at step 11.

**Note:** If the DUT does not return any door for step 3, skip steps 4-16, fail the test and go to the next test.

**Note:** If the DUT sends SOAP fault to DoubleLockDoor request then the ONVIF Client deletes Subscription Manager, starts user interaction process (see Annex A.4), and then runs the test from step 6.

**Note:** If in the Annex A.5 the DUT sends SOAP fault to request to change door mode, then the ONVIF Client starts user interaction process (see Annex A.4), and then runs the test from step 6.

**Note:** The Subscription Manager has to be deleted at the end of the test either by calling unsubscribe or through a timeout.

**Note:** The Renew has to be used for renew subscription during test, if InitialTerminationTime expires.

**Note:** If DUT cannot accept the set value to Timeout or MessageLimit, ONVIF Client retries to send the PullMessage message with Timeout and MessageLimit which is contained in PullMessagesFaultResponse.

**Note:** If DUT cannot accept the set value to a TerminationTime, ONVIF Client retries to send the Renew request MinimumTime value which is contained in UnacceptableTerminationTimeFault.

**Note:** timeout1 will be taken from Subscription Timeout field of ONVIF Device Test Tool.

## 4.3.22 LOCK DOOR

**Test Case ID:** DOORCONTROL-3-1-31

**Specification Coverage:** LockDoor (ONVIF Door Control Service Specification)

**Feature Under Test:** LockDoor**WSDL Reference:** doorcontrol.wsdl**Test Purpose:** To verify that Lock Door is accepted. To verify Door state change after Lock Door command. To verify tns1:Door/State/DoorMode property events.**Pre-Requisite:** Door Control Service was received from the DUT. At least one Door with Lock capability is configured and added to the DUT. The doors are closed and there are no schedules.**Test Configuration:** ONVIF Client and DUT**Test Procedure:**

1. Start an ONVIF Client.
2. Start the DUT.
3. Get a complete list of doors from the DUT (see [Annex A.1](#)).
4. ONVIF Client selects one door from the complete list of doors at step 3 with DoorInfo.Capabilities.Lock equal to true. If there is no such Door, fail the test and skip other steps.
5. ONVIF Client will invoke **GetDoorState** request (Token = [selected Door token]) to retrieve current state of the door.
6. Verify **GetDoorStateResponse** from the DUT.
7. If DoorState.DoorMode is equal to Unlocked or Blocked or DoubleLocked or Accessed then go to step 23.
8. ONVIF Client will invoke **CreatePullPointSubscription** request with tns1:Door/State/DoorMode Topic as Filter and an InitialTerminationTime of timeout1.
9. Verify that the DUT sends a **CreatePullPointSubscriptionResponse** message.
10. If DoorState.DoorMode is equal to LockedDown then ONVIF Client will invoke LockDownReleaseDoor request (Token = "Token1"). Otherwise, go to step 15.
11. Verify **LockDownReleaseDoorResponse** from the DUT.
12. ONVIF Client will invoke **PullMessages** command with a PullMessagesTimeout of 20s and a MessageLimit of 1.
13. Verify that the DUT sends a **PullMessagesResponse**. Repeat step 12 until timeout expires (Operation Delay option from ONVIF Device Test Tool will be used).

14. Check that the last Notification message with PropertyOperation = "Changed" contains Source.SimpleItem item with Name = "DoorToken" and Value is equal to Token1 and contains Data.SimpleItem item with Name = «State» and Value equals to "Locked".
15. If DoorState.DoorMode is equal to Locked then ONVIF Client will invoke UnlockDoor request (Token = "Token1") to move the door into state different from Locked. Otherwise, go to step 17.
16. Verify **UnlockDoorResponse** message from the DUT.
17. If DoorState.DoorMode is equal to **LockedOpen** then ONVIF Client will invoke LockOpenRelease request (Token = "Token1") to move the door into Unlocked state.
18. Verify **LockOpenReleaseResponse** message from the DUT.
19. ONVIF Client will invoke **PullMessages** command with a PullMessagesTimeout of 20s and a MessageLimit of 1.
20. Verify that the DUT sends a **PullMessagesResponse**. Repeat step 19 until timeout expires (Operation Delay option from ONVIF Device Test Tool will be used).
21. Check that the last Notification message with PropertyOperation = "Changed" contains Source.SimpleItem item with Name = "DoorToken" and Value is equal to Token1 and contains Data.SimpleItem item with Name = «State» and Value differ from "Locked".
22. ONVIF Client deletes Subscription Manager either by calling **Unsubscribe** or through a timeout and returns to the test.
23. ONVIF Client will invoke **CreatePullPointSubscription** request with tns1:Door/State/DoorMode Topic as Filter and an InitialTerminationTime of timeout1.
24. Verify that the DUT sends a **CreatePullPointSubscriptionResponse** message.
25. Execute [Annex A.3](#) to catch Initialized event for selected door.
26. ONVIF Client will invoke **LockDoor** request (Token = [selected Door token]) to change door state.
27. Verify the **LockDoorResponse** message from the DUT.
28. ONVIF Client will invoke **PullMessages** command with a PullMessagesTimeout of 20s and a MessageLimit of 1.
29. Verify that the DUT sends a **PullMessagesResponse** that contains NotificationMessages. Repeat step 28 until timeout expires (Operation Delay option from ONVIF Device Test Tool will be used).

30. Check that all Notification messages with PropertyOperation = "Changed" contain Source.SimpleItem item with Name = "DoorToken" and Value equal to selected Door Token.
31. Check that all Notification messages with PropertyOperation = "Changed" have TopicExpression equal to tns1:Door/State/DoorMode.
32. Verify that the last Notification message with PropertyOperation = "Changed" contains Data.SimpleItem item with Name = «State» and Value equal to "Locked". Check that other Notification messages contain Data.SimpleItem item with Name = «State» and Value with tdc:DoorMode type.
33. Verify received Notification messages (correct value for UTC time, TopicExpression and wsnt:Message).

**Test Result:****PASS –**

- DUT passes all assertions.

**FAIL –**

- The DUT did not send valid **GetDoorStateResponse** message.
- The DUT did not send valid **LockDoorResponse** message.
- The DUT did not send **CreatePullPointSubscriptionResponse** message.
- The DUT did not return at least one Door at step 3.
- The DUT sent an invalid Notification messages with PropertyOperation = "Changed" (correct value for UTC time, TopicExpression and wsnt:Message, Topic = "tns1:Door/State/DoorMode", contains Source.SimpleItem item with Name = "DoorToken" and Value equal to selected Door Token, contains Data.SimpleItem item with Name = «State» and Value with type equal to tdc:DoorMode) at step 29.
- The DUT sent the last Notification message with PropertyOperation = "Changed" with State value other than "Locked" at step 29.

**Note:** If the DUT does not return any door for step 3, skip steps 4-33, fail the test and go to the next test.

**Note:** If the DUT sends SOAP fault to command changing the DoorState.DoorMode at step 11 or 16 or 18 or 27 then the ONVIF Client starts user interaction process (see Annex A.4), and runs the test from step 23.

**Note:** If the DUT sends the last notification message with door state different from “Locked” at step 13, then the ONVIF Client starts user interaction process (see [Annex A.4](#)), and runs the test from step 23.

**Note:** If the DUT sends the last notification message with door state not different from “Locked” at step 20, then the ONVIF Client starts user interaction process (see [Annex A.4](#)), and runs the test from step 23.

**Note:** If in the [Annex A.5](#) the DUT sends SOAP fault to request to change door mode, then the ONVIF Client starts user interaction process (see [Annex A.4](#)), and then runs the test from step 23.

**Note:** The Subscription Manager has to be deleted at the end of the test either by calling **Unsubscribe** or through a timeout.

**Note:** The Renew has to be used for renew subscription during test, if InitialTerminationTime expires.

**Note:** If DUT cannot accept the set value to Timeout or MessageLimit, ONVIF Client retries to send the PullMessage message with Timeout and MessageLimit which is contained in PullMessagesFaultResponse.

**Note:** If DUT cannot accept the set value to a TerminationTime, ONVIF Client retries to send the Renew request MinimumTime value which is contained in UnacceptableTerminationTimeFault.

**Note:** timeout1 will be taken from Subscription Timeout field of ONVIF Device Test Tool.

### 4.3.23 UNLOCK DOOR

**Test Case ID:** DOORCONTROL-3-1-32

**Specification Coverage:** UnlockDoor (ONVIF Door Control Service Specification)

**Feature Under Test:** UnlockDoor

**WSDL Reference:** doorcontrol.wsdl

**Test Purpose:** To verify that Unlock Door is accepted or fault is returned. To verify Door state change after Unlock Door command. To verify tns1:Door/State/DoorMode property events.

**Pre-Requisite:** Door Control Service was received from the DUT. At least one Door with Unlock capability is configured and added to the DUT. The doors are closed and there are no schedules.

**Test Configuration:** ONVIF Client and DUT

**Test Procedure:**

1. Start an ONVIF Client.

2. Start the DUT.
3. Get a complete list of doors from the DUT (see [Annex A.1](#)).
4. ONVIF Client selects one door from the complete list of doors at step 3 with DoorInfo.Capabilities.Unlock equal to true and DoorInfo.Capabilities.Locked equal to true. If there is no Door with DoorInfo.Capabilities.Unlock equal to true, fail the test and skip other steps. If there is no Door with DoorInfo.Capabilities.Unlock equal to true and DoorInfo.Capabilities.Lock equal to true then ONVIF Client executes [Annex A.4](#) to start user interaction process and then goes to step 6.
5. ONVIF Client will execute [Annex A.5](#) to switch the selected door into Locked state.
6. ONVIF Client will invoke **CreatePullPointSubscription** request with tns1:Door/State/DoorMode Topic as Filter and an InitialTerminationTime of timeout1.
7. Verify that the DUT sends a **CreatePullPointSubscriptionResponse** message.
8. Execute [Annex A.3](#) to catch Initialized event for selected door.
9. ONVIF Client will invoke **UnlockDoor** request (Token = [selected Door token]) to change door state.
10. Verify the **UnlockDoorResponse** message from the DUT.
11. ONVIF Client will invoke **PullMessages** command with a PullMessagesTimeout of 20s and a MessageLimit of 1.
12. Verify that the DUT sends a **PullMessagesResponse** that contains NotificationMessages. Repeat step 11 until timeout expires (Operation Delay option from ONVIF Device Test Tool will be used).
13. Check that all Notification messages with PropertyOperation = "Changed" contain Source.SimpleItem item with Name = "DoorToken" and Value equal to selected Door Token.
14. Check that all Notification messages with PropertyOperation = "Changed" have TopicExpression equal to tns1:Door/State/DoorMode.
15. Verify that the last Notification message with PropertyOperation = "Changed" contains Data.SimpleItem item with Name = «State» and Value equal to "Unlocked". Check that other Notification messages contain Data.SimpleItem item with Name = «State» and Value with tdc:DoorMode type.
16. Verify received Notification messages (correct value for UTC time, TopicExpression and wsnt:Message).

**Test Result:**

**PASS –**

- DUT passes all assertions.

**FAIL –**

- The DUT did not send valid **UnlockDoorResponse** message.
- The DUT did not send **CreatePullPointSubscriptionResponse** message.
- The DUT did not return at least one Door at step 3.
- The DUT sent an invalid Notification messages with PropertyOperation = "Changed" (correct value for UTC time, TopicExpression and wsnt:Message, Topic = "tns1:Door/State/DoorMode", contains Source.SimpleItem item with Name = "DoorToken" and Value equal to selected Door Token, contains Data.SimpleItem item with Name = «State» and Value with type equal to tdc:DoorMode) at step 12.
- The DUT sent the last Notification message with PropertyOperation = "Changed" with State value other than "Unlocked" at step 12.

**Note:** If the DUT does not return any door for step 3, skip steps 4-16, fail the test and go to the next test.

**Note:** If the DUT sends SOAP fault to UnlockDoor request then the ONVIF Client deletes Subscription Manager, starts user interaction process (see [Annex A.4](#)), and then runs the test from step 6.

**Note:** If in the [Annex A.5](#) the DUT sends SOAP fault to request to change door mode, then the ONVIF Client starts user interaction process (see [Annex A.4](#)), and then runs the test from step 6.

**Note:** The Subscription Manager has to be deleted at the end of the test either by calling unsubscribe or through a timeout.

**Note:** The Renew has to be used for renew subscription during test, if InitialTerminationTime expires.

**Note:** Test will be failed, if no required Notification messages are received for step 9 during a certain period of time (Operation Delay should be used in ONVIF Device Test Tool).

**Note:** If DUT cannot accept the set value to Timeout or MessageLimit, ONVIF Client retries to send the PullMessage message with Timeout and MessageLimit which is contained in PullMessagesFaultResponse.

**Note:** If DUT cannot accept the set value to a TerminationTime, ONVIF Client retries to send the Renew request MinimumTime value which is contained in UnacceptableTerminationTimeFault.



**Note:** timeout1 will be taken from Subscription Timeout field of ONVIF Device Test Tool.

## 4.3.24 LOCK OPEN DOOR

**Test Case ID:** DOORCONTROL-3-1-33

**Specification Coverage:** LockOpenDoor (ONVIF Door Control Service Specification)

**Feature Under Test:** LockOpenDoor

**WSDL Reference:** doorcontrol.wsdl

**Test Purpose:** To verify that Lock Open Door is accepted. To verify Door state change after Lock Open Door command. To verify tns1:Door/State/DoorMode property events.

**Pre-Requirement:** Door Control Service was received from the DUT. At least one Door with Lock Open capability is configured and added to the DUT. The doors are closed and there are no schedules.

**Test Configuration:** ONVIF Client and DUT

### Test Procedure:

1. Start an ONVIF Client.
2. Start the DUT.
3. Get a complete list of doors from the DUT (see [Annex A.1](#)).
4. ONVIF Client selects one door from the complete list of doors at step 3 with DoorInfo.Capabilities.LockOpen equal to true and DoorInfo.Capabilities.Locked equal to true. If there is no Door with DoorInfo.Capabilities.LockOpen equal to true, fail the test and skip other steps. If there is no Door with DoorInfo.Capabilities.LockOpen equal to true and DoorInfo.Capabilities.Lock equal to true then ONVIF Client executes [Annex A.4](#) to start user interaction process and then goes to step 6.
5. ONVIF Client will execute [Annex A.5](#) to switch the selected door into Locked state.
6. ONVIF Client will invoke **CreatePullPointSubscription** request with tns1:Door/State/DoorMode Topic as Filter and an InitialTerminationTime of timeout1.
7. Verify that the DUT sends a **CreatePullPointSubscriptionResponse** message.
8. Execute [Annex A.3](#) to catch Initialized event for selected door.
9. ONVIF Client will invoke **LockOpenDoor** request (Token = [selected Door token]) to change door state.

10. Verify the **LockOpenDoorResponse** message from the DUT.
11. ONVIF Client will invoke **PullMessages** command with a PullMessagesTimeout of 20s and a MessageLimit of 1.
12. Verify that the DUT sends a **PullMessagesResponse** that contains NotificationMessages. Repeat step 11 until timeout expires (Operation Delay option from ONVIF Device Test Tool will be used).
13. Check that all Notification messages with PropertyOperation = "Changed" contain Source.SimpleItem item with Name = "DoorToken" and Value equal to selected Door Token.
14. Check that all Notification messages with PropertyOperation = "Changed" have TopicExpression is equal to tns1:Door/State/DoorMode.
15. Verify that the last Notification message with PropertyOperation = "Changed" contains Data.SimpleItem item with Name = «State» and Value equal to "LockedOpen". Check that other Notification messages contain Data.SimpleItem item with Name = «State» and Value with tdc:DoorMode type.
16. Verify received Notification messages (correct value for UTC time, TopicExpression and wsnt:Message).

**Test Result:****PASS –**

- DUT passes all assertions.

**FAIL –**

- The DUT did not send valid **LockOpenDoorResponse** message.
- The DUT did not send **CreatePullPointSubscriptionResponse** message.
- The DUT did not return at least one Door at step 3.
- The DUT sent an invalid Notification messages with PropertyOperation = "Changed" (correct value for UTC time, TopicExpression and wsnt:Message, Topic = "tns1:Door/State/DoorMode", contains Source.SimpleItem item with Name = "DoorToken" and Value equal to selected Door Token, contains Data.SimpleItem item with Name = «State» and Value with type equal to tdc:DoorMode) at step 12.
- The DUT sent the last Notification message with PropertyOperation = "Changed" with State value other than "LockedOpen" at step 12.

**Note:** If the DUT does not return any door for step 3, skip steps 4-16, fail the test and go to the next test.

**Note:** If the DUT sends SOAP fault to LockOpenDoor request then the ONVIF Client deletes Subscription Manager, starts user interaction process (see Annex A.4), and then runs the test from step 6.

**Note:** If in the Annex A.5 the DUT sends SOAP fault to request to change door mode, then the ONVIF Client starts user interaction process (see Annex A.4), and then runs the test from step 6.

**Note:** The Subscription Manager has to be deleted at the end of the test either by calling unsubscribe or through a timeout.

**Note:** The Renew has to be used for renew subscription during test, if InitialTerminationTime expires.

**Note:** If DUT cannot accept the set value to Timeout or MessageLimit, ONVIF Client retries to send the PullMessage message with Timeout and MessageLimit which is contained in PullMessagesFaultResponse.

**Note:** If DUT cannot accept the set value to a TerminationTime, ONVIF Client retries to send the Renew request MinimumTime value which is contained in UnacceptableTerminationTimeFault.

**Note:** timeout1 will be taken from Subscription Timeout field of ONVIF Device Test Tool.

## 4.3.25 LOCK OPEN RELEASE DOOR

**Test Case ID:** DOORCONTROL-3-1-34

**Specification Coverage:** LockOpenReleaseDoor (ONVIF Door Control Service Specification)

**Feature Under Test:** LockOpenReleaseDoor

**WSDL Reference:** doorcontrol.wsdl

**Test Purpose:** To verify that Lock Open Release Door is accepted. To verify Door state change after Lock Open Release Door command. To verify tns1:Door/State/DoorMode property events.

**Pre-Requisite:** Door Control Service was received from the DUT. At least one Door with Lock Open capability is configured and added to the DUT. The doors are closed and there are no schedules.  
Test Configuration: ONVIF Client and DUT

**Test Configuration:** ONVIF Client and DUT

**Test Procedure:**

1. Start an ONVIF Client.
2. Start the DUT.
3. Get a complete list of doors from the DUT (see [Annex A.1](#)).
4. ONVIF Client selects one door from the complete list of doors at step 3 with DoorInfo.Capabilities.LockOpen equal to true and DoorInfo.Capabilities.Locked equal to true. If there is no Door with DoorInfo.Capabilities.LockOpen equal to true, fail the test and skip other steps. If there is no Door with DoorInfo.Capabilities.LockOpen equal to true and DoorInfo.Capabilities.Lock equal to true then ONVIF Client executes [Annex A.4](#) to start user interaction process and then goes to step 14.
5. ONVIF Client will invoke **GetDoorState** request (Token = "Token1", where Token1 is selected door) to retrieve current state of the door.
6. Verify **GetDoorStateResponse** from the DUT. If DoorState.DoorMode is equal to LockedOpen then skip steps 7-15 and go to step 16.
7. ONVIF Client will execute [Annex A.5](#) to switch the selected door into Locked state.
8. ONVIF Client will invoke **CreatePullPointSubscription** request with tns1:Door/State/DoorMode Topic as Filter and an InitialTerminationTime of timeout1.
9. Verify that the DUT sends a **CreatePullPointSubscriptionResponse** message.
10. ONVIF Client will invoke **LockOpenDoor** request (Token = [selected Door token]) to move the door in LockedOpen state.
11. Verify **LockOpenDoorResponse** message from the DUT.
12. ONVIF Client will invoke **PullMessages** command with a PullMessagesTimeout of 20s and a MessageLimit of 1.
13. Verify that the DUT sends a **PullMessagesResponse**. Repeat step 12 until timeout expires (Operation Delay option from ONVIF Device Test Tool will be used).
14. Check that the last Notification message with PropertyOperation = "Changed" contains Source.SimpleItem item with Name = "DoorToken" and Value equal to selected door token and contains Data.SimpleItem item with Name = «State» and Value equal to "LockedOpen".
15. ONVIF Client deletes Subscription Manager either by calling **Unsubscribe** or through a timeout.
16. ONVIF Client will invoke **CreatePullPointSubscription** request with tns1:Door/State/DoorMode Topic as Filter and an InitialTerminationTime of timeout1.

17. Verify that the DUT sends a **CreatePullPointSubscriptionResponse** message.
18. Execute [Annex A.3](#) to catch Initialized event for selected door. State of the Door received in [Annex A.3](#) will be assumed as initial State of this Door.
19. Check that initial state of the Door equals to "LockedOpen".
20. ONVIF Client will invoke **LockOpenReleaseDoor** request (Token = [selected Door token]) to change door state.
21. Verify the **LockOpenDoorReleaseResponse** message from the DUT.
22. ONVIF Client will invoke **PullMessages** command with a PullMessagesTimeout of 20s and a MessageLimit of 1.
23. Verify that the DUT sends a **PullMessagesResponse** that contains NotificationMessages. Repeat step [22](#) until timeout expires (Operation Delay option from ONVIF Device Test Tool will be used).
24. Check that all Notification messages with PropertyOperation = "Changed" contain Source.SimpleItem item with Name = "DoorToken" and Value equal to selected Door Token.
25. Check that all Notification messages with PropertyOperation = "Changed" have TopicExpression is equal to tns1:Door/State/DoorMode.
26. Verify that last Notification message with PropertyOperation = "Changed" contains Data.SimpleItem item with Name = «State» and Value other than "LockedOpen". Check that other Notification messages contain Data.SimpleItem item with Name = «State» and Value with tdc:DoorMode type.
27. Verify received Notification messages (correct value for UTC time, TopicExpression and wsnt:Message).

**Test Result:****PASS –**

- DUT passes all assertions.

**FAIL –**

- The DUT did not send valid **LockOpenReleaseDoorResponse** message.
- The DUT did not send **CreatePullPointSubscriptionResponse** message.
- The DUT did not return at least one Door at step [3](#).

- The DUT sent the last Notification message with PropertyOperation = "Changed" with State value not equal to "LockedOpen" at step 13.
- The DUT sent Notification message for selected door token with PropertyOperation = "Initialized" with State value not equal to "LockedOpen" at step 18.
- The DUT sent an invalid Notification messages with PropertyOperation = "Changed" (correct value for UTC time, TopicExpression and wsnt:Message, Topic = "tns1:Door/State/DoorMode", contains Source.SimpleItem item with Name = "DoorToken" and Value equal to selected Door Token, contains Data.SimpleItem item with Name = «State» and Value with type equal to tdc:DoorMode) at step 23.
- The DUT sent the last Notification message with PropertyOperation = "Changed" with State value equal to "LockedOpen" at step 23.

**Note:** If the DUT does not return any door for step 3, skip steps 4-27, fail the test and go to the next test.

**Note:** If the DUT sends SOAP fault to LockOpenDoor request or to LockOpenRealiseDoorRequest then the ONVIF Client deletes Subscription Manager, starts user interaction process (see Annex A.4), and then runs the test from step 16.

**Note:** If in the Annex A.5 the DUT sends SOAP fault to request to change door mode, then the ONVIF Client starts user interaction process (see Annex A.4), and then runs the test from step 16.

**Note:** The Subscription Manager has to be deleted at the end of the test either by calling unsubscribe or through a timeout.

**Note:** The Renew has to be used for renew subscription during test, if InitialTerminationTime expires.

**Note:** If DUT cannot accept the set value to Timeout or MessageLimit, ONVIF Client retries to send the PullMessage message with Timeout and MessageLimit which is contained in PullMessagesFaultResponse.

**Note:** If DUT cannot accept the set value to a TerminationTime, ONVIF Client retries to send the Renew request MinimumTime value which is contained in UnacceptableTerminationTimeFault.

**Note:** timeout1 will be taken from Subscription Timeout field of ONVIF Device Test Tool.

## 4.3.26 LOCK DOWN DOOR

**Test Case ID:** DOORCONTROL-3-1-35

**Specification Coverage:** LockDownDoor (ONVIF Door Control Service Specification)

**Feature Under Test:** LockDownDoor

**WSDL Reference:** doorcontrol.wsdl

**Test Purpose:** To verify that Lock Down Door is accepted. To verify Door state change after Lock Down Door command. To verify tns1:Door/State/DoorMode property events.

**Pre-Requisite:** Door Control Service was received from the DUT. At least one Door with Lock Down capability is configured and added to the DUT. The doors are closed and there are no schedules.

**Test Configuration:** ONVIF Client and DUT

**Test Procedure:**

1. Start an ONVIF Client.
2. Start the DUT.
3. Get a complete list of doors from the DUT (see [Annex A.1](#)).
4. ONVIF Client selects one door from the complete list of doors at step 3 with DoorInfo.Capabilities.LockDown equal to true and DoorInfo.Capabilities.Locked equal to true. If there is no Door with DoorInfo.Capabilities.LockDown equal to true, fail the test and skip other steps. If there is no Door with DoorInfo.Capabilities.LockDown equal to true and DoorInfo.Capabilities.Lock equal to true then ONVIF Client executes [Annex A.4](#) to start user interaction process and then goes to step 6.
5. ONVIF Client will execute [Annex A.5](#) to switch the selected door into Locked state.
6. ONVIF Client will invoke **CreatePullPointSubscription** request with tns1:Door/State/DoorMode Topic as Filter and an InitialTerminationTime of timeout1.
7. Verify that the DUT sends a **CreatePullPointSubscriptionResponse** message.
8. Execute [Annex A.3](#) to catch Initialized event for selected door.
9. ONVIF Client will invoke **LockDownDoor** request (Token = [selected Door token]) to change door state.
10. Verify the **LockDownDoorResponse** message from the DUT.
11. ONVIF Client will invoke **PullMessages** command with a PullMessagesTimeout of 20s and a MessageLimit of 1.
12. Verify that the DUT sends a **PullMessagesResponse** that contains NotificationMessages. Repeat step 11 until timeout expires (Operation Delay option from ONVIF Device Test Tool will be used).

13. Check that all Notification messages with PropertyOperation = "Changed" contain Source.SimpleItem item with Name = "DoorToken" and Value equal to selected Door Token.
14. Check that all Notification messages with PropertyOperation = "Changed" have TopicExpression is equal to tns1:Door/State/DoorMode.
15. Verify that the last Notification message with PropertyOperation = "Changed" contains Data.SimpleItem item with Name = «State» and Value equal to "LockedDown". Check that other Notification messages contain Data.SimpleItem item with Name = «State» and Value with tdc:DoorMode type.
16. Verify received Notification messages (correct value for UTC time, TopicExpression and wsnt:Message).

**Test Result:****PASS –**

- DUT passes all assertions.

**FAIL –**

- The DUT did not send valid **LockDownDoorResponse** message.
- The DUT did not send **CreatePullPointSubscriptionResponse** message.
- The DUT did not return at least one Door at step 3.
- The DUT sent an invalid Notification messages with PropertyOperation = "Changed" (correct value for UTC time, TopicExpression and wsnt:Message, Topic = "tns1:Door/State/DoorMode", contains Source.SimpleItem item with Name = "DoorToken" and Value equal to selected Door Token, contains Data.SimpleItem item with Name = «State» and Value with type equal to tdc:DoorMode) at step 12.
- The DUT sent the last Notification message with PropertyOperation = "Changed" with State value other than "LockedDown" at step 12.

**Note:** If the DUT does not return any door for step 3, skip steps 4-16, fail the test and go to the next test.

**Note:** If the DUT sends SOAP fault to LockDownDoor request, then the ONVIF Client deletes Subscription Manager, starts user interaction process (see Annex A.4), and then runs the test from step 6.

**Note:** If in the Annex A.5 the DUT sends SOAP fault to request to change door mode, then the ONVIF Client starts user interaction process (see Annex A.4), and then runs the test from step 6.



**Note:** The Subscription Manager has to be deleted at the end of the test either by calling unsubscribe or through a timeout.

**Note:** The Renew has to be used for renew subscription during test, if InitialTerminationTime expires.

**Note:** If DUT cannot accept the set value to Timeout or MessageLimit, ONVIF Client retries to send the PullMessage message with Timeout and MessageLimit which is contained in PullMessagesFaultResponse.

**Note:** If DUT cannot accept the set value to a TerminationTime, ONVIF Client retries to send the Renew request MinimumTime value which is contained in UnacceptableTerminationTimeFault.

**Note:** timeout1 will be taken from Subscription Timeout field of ONVIF Device Test Tool.

## 4.3.27 LOCK DOWN RELEASE DOOR

**Test Case ID:** DOORCONTROL-3-1-36

**Specification Coverage:** LockDownReleaseDoor (ONVIF Door Control Service Specification)

**Feature Under Test:** LockDownReleaseDoor

**WSDL Reference:** doorcontrol.wsdl

**Test Purpose:** To verify that Lock Down Release Door is accepted. To verify Door state change after Lock Down Release Door command. To verify tns1:Door/State/DoorMode property events.

**Pre-Requisite:** Door Control Service was received from the DUT. At least one Door with Lock Down capability is configured and added to the DUT. The doors are closed and there are no schedules.

**Test Configuration:** ONVIF Client and DUT

**Test Procedure:**

1. Start an ONVIF Client.
2. Start the DUT.
3. Get a complete list of doors from the DUT (see [Annex A.1](#)).
4. ONVIF Client selects one door from the complete list of doors at step 3 with DoorInfo.Capabilities.LockDown equal to true and DoorInfo.Capabilities.Locked equal to true. If there is no Door with DoorInfo.Capabilities.LockDown equal to true, fail the test and skip other steps. If there is no Door with DoorInfo.Capabilities.LockDown equal to true and DoorInfo.Capabilities.Lock equal to true then ONVIF Client executes [Annex A.4](#) to start user interaction process and then goes to step 14.

5. ONVIF Client will invoke **GetDoorState** request (Token = "Token1", where Token1 is selected door) to retrieve current state of the door.
6. Verify **GetDoorStateResponse** from the DUT. If DoorState.DoorMode is equal to LockedDown then skip steps 7-15 and go to step 16.
7. ONVIF Client will execute [Annex A.5](#) to switch the selected door into Locked state.
8. ONVIF Client will invoke **CreatePullPointSubscription** request with tns1:Door/State/DoorMode Topic as Filter and an InitialTerminationTime of timeout1.
9. Verify that the DUT sends a **CreatePullPointSubscriptionResponse** message.
10. ONVIF Client will invoke **LockDownDoor** request (Token = [selected Door token]) to move the door in LockedDown state.
11. Verify **LockDownDoorResponse** message from the DUT.
12. ONVIF Client will invoke **PullMessages** command with a PullMessagesTimeout of 20s and a MessageLimit of 1.
13. Verify that the DUT sends a **PullMessagesResponse**. Repeat step 12 until timeout expires (Operation Delay option from ONVIF Device Test Tool will be used).
14. Verify that the last Notification message with PropertyOperation = "Changed" contains Source.SimpleItem item with Name = "DoorToken" and Value equal to selected door token and contains Data.SimpleItem item with Name = «State» and Value equal to "LockedDown".
15. ONVIF Client deletes Subscription Manager either by calling **Unsubscribe** or through a timeout.
16. ONVIF Client will invoke **CreatePullPointSubscription** request with tns1:Door/State/DoorMode Topic as Filter and an InitialTerminationTime of timeout1.
17. Verify that the DUT sends a **CreatePullPointSubscriptionResponse** message.
18. Execute [Annex A.3](#) to catch Initialized event for selected door. State of the Door received in [Annex A.3](#) will be assumed as initial State of this Door.
19. Check that initial state of the Door equals to "LockedDown".
20. ONVIF Client will invoke **LockDownReleaseDoor** request (Token = [selected Door token]) to change door state.
21. Verify the **LockDownReleaseDoorResponse** message from the DUT.
22. ONVIF Client will invoke **PullMessages** command with a PullMessagesTimeout of 20s and a MessageLimit of 1.

23. Verify that the DUT sends a **PullMessagesResponse** that contains NotificationMessages. Repeat step 22 until timeout has expired (Operation Delay option from ONVIF Device Test Tool will be used).
24. Check that all Notification messages with PropertyOperation = "Changed" contain Source.SimpleItem item with Name = "DoorToken" and Value equal to selected Door Token.
25. Check that all Notification messages with PropertyOperation = "Changed" have TopicExpression is equal to tns1:Door/State/DoorMode.
26. Verify that the last Notification message with PropertyOperation = "Changed" contains Data.SimpleItem item with Name = «State» and Value other than "LockedDown". Check that other Notification messages contain Data.SimpleItem item with Name = «State» and Value with tdc:DoorMode type.
27. Verify received Notification messages (correct value for UTC time, TopicExpression and wsnt:Message).

**Test Result:****PASS –**

- DUT passes all assertions.

**FAIL –**

- The DUT did not send valid **LockDownReleaseDoorResponse** message.
- The DUT did not send **CreatePullPointSubscriptionResponse** message.
- The DUT did not return at least one Door at step 3.
- The DUT sent the last Notification message with PropertyOperation = "Changed" with State value not equal to "LockedDown" at step 13.
- The DUT sent Notification message for selected door token with PropertyOperation = "Initialized" with State value not equal to "LockedDown" at step 18.
- The DUT sent an invalid Notification messages with PropertyOperation = "Changed" (correct value for UTC time, TopicExpression and wsnt:Message, Topic = "tns1:Door/State/DoorMode", contains Source.SimpleItem item with Name = "DoorToken" and Value equal to selected Door Token, contains Data.SimpleItem item with Name = «State» and Value with type equal to tdc:DoorMode) at step 23.
- The DUT sent the last Notification message with PropertyOperation = "Changed" with State value equal to "LockedDown" at step 23.

**Note:** If the DUT does not return any door for step 3, skip steps 4-27, fail the test and go to the next

**Note:** If the DUT sends SOAP fault to LockDownDoor request or to LockDownReleaseDoorRequest then the ONVIF Client deletes Subscription Manager, starts user interaction process (see [Annex A.4](#)), and then runs the test from step 16.

**Note:** If in the [Annex A.5](#) the DUT sends SOAP fault to request to change door mode, then the ONVIF Client starts user interaction process (see [Annex A.4](#)), and then runs the test from step 16.

**Note:** The Subscription Manager has to be deleted at the end of the test either by calling unsubscribe or through a timeout.

**Note:** The Renew has to be used for renew subscription during test, if InitialTerminationTime expires.

**Note:** If DUT cannot accept the set value to Timeout or MessageLimit, ONVIF Client retries to send the PullMessage message with Timeout and MessageLimit which is contained in PullMessagesFaultResponse.

**Note:** If DUT cannot accept the set value to a TerminationTime, ONVIF Client retries to send the Renew request MinimumTime value which is contained in UnacceptableTerminationTimeFault.

**Note:** timeout1 will be taken from Subscription Timeout field of ONVIF Device Test Tool.

## 4.4 Consistency

### 4.4.1 GET ACCESS POINT INFO LIST AND GET DOOR INFO LIST CONSISTENCY

**Test Case ID:** DOORCONTROL-5-1-1

**Specification Coverage:** GetDoorInfoList (ONVIF Door Control Service Specification), GetAccessPointInfoList (ONVIF Access Control Service Specification)

**Feature Under Test:** GetDoorInfoList, GetAccessPointInfoList

**WSDL Reference:** accesscontrol.wsdl, doorcontrol.wsdl

**Test Purpose:** To verify that Door Info List contains all Doors from Access Point Info List.

**Pre-Requisite:** Access Control Service was received from the DUT. Door Control Service address was received from the DUT. At least one Door is configured and added to the DUT. At least one Access Point is configured and added to the DUT.

**Test Configuration:** ONVIF Client and DUT

**Test Procedure:**

1. Start an ONVIF Client.
2. Start the DUT.
3. Get a complete list of doors from the DUT (see [Annex A.1](#))
4. Get a complete list of access points from the DUT (see [Annex A.2](#))
5. Verify that the complete list of doors contains all Doors included in the complete list of access points in Entity element in case Type is skipped or equal to tdc:Door.

**Test Result:****PASS –**

- DUT passes all assertions.

**FAIL –**

- The DUT returned at least one Door listed in Entity element of AccessPointInfo listed in the complete list of access points in case Type is skipped or equal to tdc:Door that was not included in the complete list of doors.
- The DUT did not return at least one Door at step 3.
- The DUT did not return at least one Access Point at step 4.

## 4.5 Property Events

### 4.5.1 DOOR CONTROL – DOOR MODE EVENT

**Test Case ID:** DOORCONTROL-6-1-1

**Specification Coverage:** tns1:Door/State/DoorMode (ONVIF Door Control Service Specification), GetDoorState (ONVIF Door Control Service Specification), Properties (ONVIF Core Specification)

**Feature Under Test:** GetDoorState

**WSDL Reference:** event.wsdl, doorcontrol.wsdl

**Test Purpose:** To verify tns1:Door/State/DoorMode event generation after subscription and to verify tns1:Door/State/DoorMode event format.

**Pre-Requisite:** Event Service was received from the DUT. Door Control Service was received from the DUT. At least one Door is configured and added to the DUT.

## Test Configuration: ONVIF Client and DUT

### Test Procedure:

1. Start an ONVIF Client.
2. Start the DUT.
3. Get a complete list of doors from the DUT (see [Annex A.1](#)).
4. ONVIF Client will invoke **GetEventProperties** request to retrieve all events supported by the DUT.
5. Verify the **GetEventPropertiesResponse** message from the DUT.
6. Check if there is an event with Topic `tns1:Door/State/DoorMode`. If there is no event with such Topic skip other steps, fail the test and go to the next test.
7. Check that this event is a Property event (`MessageDescription.IsProperty = "true"`).
8. Check that this event contains `Source.SimpleItemDescription` item with `Name = "DoorToken"` and `Type = "pt:ReferenceToken"`.
9. Check that this event contains `Data.SimpleItemDescription` item with `Name = «State»` and `Type = "tdc:DoorMode"`.
10. ONVIF Client will invoke **CreatePullPointSubscription** request with `tns1:Door/State/DoorMode` Topic as Filter and an `InitialTerminationTime` of `timeout1`.
11. Verify that the DUT sends a **CreatePullPointSubscriptionResponse** message.
12. ONVIF Client will invoke **PullMessages** command with a `PullMessagesTimeout` of 20s and a `MessageLimit` of 1.
13. Verify that the DUT sends a **PullMessagesResponse** that contains `NotificationMessages`. Repeat step 12 until Notification for all Doors is received.
14. Verify the received Notify messages (correct value for UTC time, `TopicExpression` and `wsnt:Message`).
15. Verify that `TopicExpression` is equal to `tns1:Door/State/DoorMode` for all received Notify messages.
16. Verify that each notification contains `Source.SimpleItem` item with `Name = "DoorToken"` and `Value` is equal to one of existing Door Tokens (e.g. complete list of doors contains Door with the same token). Verify that there are Notification messages for each Door.

17. Verify that each notification contains Data.SimpleItem item with Name = «State» and Value with type is equal to tdc:DoorMode.
18. Verify that Notify PropertyOperation = "Initialized".
19. ONVIF Client will invoke **GetDoorState** request for each Door with corresponding tokens.
20. Verify the **GetDoorStateResponse** messages from the DUT. Verify that Data.SimpleItem item with Name = «State» from Notification message has the same value with DoorMode elements from corresponding **GetDoorStateResponse** messages for each Door.

**Test Result:****PASS –**

- DUT passes all assertions.

**FAIL –**

- The DUT did not send a **GetEventPropertiesResponse**
- The DUT did not send **CreatePullPointSubscriptionResponse** message.
- The DUT did not send **PullMessagesResponse** message.
- The DUT did not send valid SubscriptionReference.
- The DUT did not send a Notification message that contains a property event tns1:Door/State/DoorMode at least for one Door.
- The DUT sent an invalid Notification message (no corresponding Source.SimpleItem or Data.SimpleItem, wrong type of Value fields, invalid DoorToken or State values, PropertyOperation is not equal to "Initialized").
- The DUT did not return at least one Door at step 3.
- The DUT did not return Topic tns1:Door/State/DoorMode in **GetEventPropertiesResponse**.

**Note:** The Subscription Manager has to be deleted at the end of the test either by calling unsubscribe or through a timeout.

**Note:** The Subscription Manager has to be deleted at the end of the test either by calling unsubscribe or through a timeout.

**Note:** ONVIF Client at step 13 will wait for Notification messages until notification for all Doors is received or Operation Delay has expired. Notification messages for all Doors are assumed as received, if the number of Notification messages is equal to the number of Doors.

**Note:** If the DUT does not return any door for step 3, skip steps 4-20, fail the test and go to the next test.

**Note:** The Subscription Manager has to be deleted at the end of the test either by calling unsubscribe or through a timeout.

**Note:** The Renew has to be used for renew subscription during test, if InitialTerminationTime expires.

**Note:** If DUT cannot accept the set value to Timeout or MessageLimit, ONVIF Client retries to send the PullMessage message with Timeout and MessageLimit which is contained in PullMessagesFaultResponse.

**Note:** If DUT cannot accept the set value to a TerminationTime, ONVIF Client retries to send the Renew request MinimumTime value which is contained in UnacceptableTerminationTimeFault.

**Note:** timeout1 will be taken from Subscription Timeout field of ONVIF Device Test Tool.

## 4.5.2 DOOR CONTROL – DOOR PHYSICAL STATE EVENT

**Test Case ID:** DOORCONTROL-6-1-2

**Specification Coverage:** tns1:Door/State/DoorPhysicalState (ONVIF Door Control Service Specification), GetDoorState (ONVIF Door Control Service Specification), Properties (ONVIF Core Specification)

**Feature Under Test:** GetDoorState

**WSDL Reference:** event.wsdl, doorcontrol.wsdl

**Test Purpose:** To verify tns1:Door/State/DoorPhysicalState event generation after subscription and to verify tns1:Door/State/DoorPhysicalState event format.

**Pre-Requisite:** Event Service was received from the DUT. Door Control Service was received from the DUT. At least one Door with Door Monitor capability is configured and added to the DUT.

**Test Configuration:** ONVIF Client and DUT

**Test Procedure:**

1. Start an ONVIF Client.
2. Start the DUT.
3. Get a complete list of doors from the DUT (see [Annex A.1](#)).



4. Check that there is at least one Door with Capabilities.DoorMonitor = "true". Otherwise fail the test and skip other steps.
5. ONVIF Client will invoke **GetEventProperties** request to retrieve all events supported by the DUT.
6. Verify the **GetEventPropertiesResponse** message from the DUT.
7. Check if there is an event with Topic tns1:Door/State/DoorPhysicalState. If there is no event with such Topic skip other steps, fail the test and go to the next test.
8. Check that this event is a Property event (MessageDescription.IsProperty = "true").
9. Check that this event contains Source.SimpleItemDescription item with Name = "DoorToken" and Type = "pt:ReferenceToken".
10. Check that this event contains Data.SimpleItemDescription item with Name = "State" and Type = "tdc:DoorPhysicalState".
11. ONVIF Client will invoke **CreatePullPointSubscription** request with tns1:Door/State/DoorPhysicalState Topic as Filter and an InitialTerminationTime of timeout1.
12. Verify that the DUT sends a **CreatePullPointSubscriptionResponse** message.
13. ONVIF Client will invoke **PullMessages** command with a PullMessagesTimeout of 20s and a MessageLimit of 1.
14. Verify that the DUT sends a **PullMessagesResponse** that contains NotificationMessages. Repeat step 13 until Notification for all Doors with Capabilities.DoorMonitor = "true" is received.
15. Verify received Notify messages (correct value for UTC time, TopicExpression and wsnt:Message).
16. Verify that TopicExpression is equal to tns1:Door/State/DoorPhysicalState for all received Notify messages.
17. Verify that each notification contains Source.SimpleItem item with Name = "DoorToken" and Value is equal to one of existing Door Tokens Capabilities.DoorMonitor = "true" (e.g. complete list of doors contains Door with the same token). Verify that there are Notification messages for each Door with Capabilities.DoorMonitor = "true".
18. Verify that each notification contains Data.SimpleItem item with Name = "State" and Value with type is equal to tdc:DoorPhysicalState.
19. Verify that Notify PropertyOperation = "Initialized".

20. ONVIF Client will invoke GetDoorState request for each Door with corresponding tokens.

21. Verify the **GetDoorStateResponse** messages from the DUT. Verify that Data.SimpleItem item with Name = "State" from Notification message has the same value with DoorPhysicalState elements from corresponding **GetDoorStateResponse** messages for each Door with Capabilities.DoorMonitor = "true".

#### Test Result:

##### PASS –

- DUT passes all assertions.

##### FAIL –

- The DUT did not send a **GetEventPropertiesResponse**
- The DUT did not send **CreatePullPointSubscriptionResponse** message.
- The DUT did not send **PullMessagesResponse** message.
- The DUT did not send valid SubscriptionReference.
- The DUT did not send a Notification message that contains a property event tns1:Door/State/DoorPhysicalState at least for one Door with Capabilities.DoorMonitor = "true".
- The DUT sent an invalid Notification message (no corresponding Source.SimpleItem or Data.SimpleItem, wrong type of Value fields, invalid DoorToken or State values, PropertyOperation is not equal to "Initialized").
- The DUT did not return at least one Door at step 3.
- The DUT did not return Topic tns1:Door/State/DoorPhysicalState in **GetEventPropertiesResponse**.

**Note:** The Subscription Manager has to be deleted at the end of the test either by calling unsubscribe or through a timeout.

**Note:** ONVIF Client at step 14 will wait for Notification messages until notification for all Doors with Capabilities.DoorMonitor = "true" is received or Operation Delay has expired. Notification messages for all Doors with Capabilities.DoorMonitor = "true" are assumed as received, if the number of Notification messages is equal to the number of Doors with Capabilities.DoorMonitor = "true".

**Note:** If the DUT does not return any door for step 3, skip steps 4-21, fail the test and go to the next test.

**Note:** The Subscription Manager has to be deleted at the end of the test either by calling unsubscribe or through a timeout.

**Note:** The Renew has to be used for renew subscription during test, if InitialTerminationTime expires.

**Note:** If DUT cannot accept the set value to Timeout or MessageLimit, ONVIF Client retries to send the PullMessage message with Timeout and MessageLimit which is contained in PullMessagesFaultResponse.

**Note:** If DUT cannot accept the set value to a TerminationTime, ONVIF Client retries to send the Renew request MinimumTime value which is contained in UnacceptableTerminationTimeFault.

**Note:** timeout1 will be taken from Subscription Timeout field of ONVIF Device Test Tool.

### 4.5.3 DOOR CONTROL – DOOR PHYSICAL STATE EVENT STATE CHANGE

**Test Case ID:** DOORCONTROL-6-1-3

**Specification Coverage:** tns1:Door/State/DoorPhysicalState (ONVIF Door Control Service Specification)

**Feature Under Test:** None

**WSDL Reference:** event.wsdl, doorcontrol.wsdl

**Test Purpose:** To verify tns1:Door/State/DoorPhysicalState event generation after property was changed and to verify tns1:Door/State/DoorPhysicalState event format.

**Pre-Requirement:** Event Service was received from the DUT. Door Control Service was received from the DUT. At least one Door with Door Monitor capability is configured and added to the DUT.

**Test Configuration:** ONVIF Client and DUT

**Test Procedure:**

1. Start an ONVIF Client.
2. Start the DUT.
3. Get a complete list of doors from the DUT (see [Annex A.1](#)).
4. Check that there is at least one Door with Capabilities.DoorMonitor = "true". Otherwise fail the test and skip other steps.
5. ONVIF Client will select one first Door (token = Token1) with Capabilities.DoorMonitor = "true".

6. ONVIF Client will invoke **CreatePullPointSubscription** request with `tns1:Door/State/DoorPhysicalState` Topic as Filter and an `InitialTerminationTime` of `timeout1`.
7. Verify that the DUT sends a **CreatePullPointSubscriptionResponse** message.
8. Test Operator will invoke change of `DoorPhysicalState` property for Door with `token = Token1`.
9. ONVIF Client will invoke **PullMessages** command with a `PullMessagesTimeout` of 20s and a `MessageLimit` of 1.
10. Verify that the DUT sends a **PullMessagesResponse** that contains `NotificationMessages`. Repeat step 9 until Notification with `PropertyOperation = "Changed"` for Door with `Capabilities.DoorMonitor = "true"` is received.
11. Verify received Notify messages (correct value for UTC time, `TopicExpression` and `wsnt:Message`).
12. Verify that `TopicExpression` is equal to `tns1:Door/State/DoorPhysicalState` for received Notify message.
13. Verify that notification contains `Source.SimpleItem` item with `Name = "DoorToken"` and `Value = "Token1"`.
14. Verify that notification contains `Data.SimpleItem` item with `Name = "State"` and `Value` with type is equal to `tdc:DoorPhysicalState`.

**Test Result:****PASS –**

- DUT passes all assertions.

**FAIL –**

- The DUT did not send **CreatePullPointSubscriptionResponse** message.
- The DUT did not send **PullMessagesResponse** message.
- The DUT did not send valid `SubscriptionReference`.
- The DUT did not send a Notification message that contains a property event `tns1:Door/State/DoorPhysicalState` with valid `DoorToken`.
- The DUT sent an invalid Notification message (no corresponding `Source.SimpleItem` or `Data.SimpleItem`, wrong type of `Value` fields, invalid `DoorToken` value).

- The DUT did not return at least one Door at step 3.

**Note:** The Subscription Manager has to be deleted at the end of the test either by calling unsubscribe or through a timeout.

**Note:** All Notification messages except messages with PropertyOperation = "Changed" will be ignored.

**Note:** Test will be failed, if no required Notification messages are received for step 10 during a certain period of time (Operation Delay should be used in ONVIF Device Test Tool).

**Note:** If the DUT does not return any door for step 3, skip steps 4-14, fail the test and go to the next test.

**Note:** The Subscription Manager has to be deleted at the end of the test either by calling unsubscribe or through a timeout.

**Note:** The Renew has to be used for renew subscription during test, if InitialTerminationTime expires.

**Note:** If DUT cannot accept the set value to Timeout or MessageLimit, ONVIF Client retries to send the PullMessage message with Timeout and MessageLimit which is contained in PullMessagesFaultResponse.

**Note:** If DUT cannot accept the set value to a TerminationTime, ONVIF Client retries to send the Renew request MinimumTime value which is contained in UnacceptableTerminationTimeFault.

**Note:** timeout1 will be taken from Subscription Timeout field of ONVIF Device Test Tool.

## 4.5.4 DOOR CONTROL – DOUBLE LOCK PHYSICAL STATE EVENT

**Test Case ID:** DOORCONTROL-6-1-4

**Specification Coverage:** tns1:Door/State/DoubleLockPhysicalState (ONVIF Door Control Service Specification), GetDoorState (ONVIF Door Control Service Specification), Properties (ONVIF Core Specification)

**Feature Under Test:** GetDoorState

**WSDL Reference:** event.wsdl, doorcontrol.wsdl

**Test Purpose:** To verify tns1:Door/State/DoubleLockPhysicalState event generation after subscription and to verify tns1:Door/State/DoubleLockPhysicalState event format.

**Pre-Requisite:** Event Service was received from the DUT. Door Control Service was received from the DUT. At least one Door with Double Lock Monitor capability is configured and added to the DUT.

**Test Configuration:** ONVIF Client and DUT

**Test Procedure:**

1. Start an ONVIF Client.
2. Start the DUT.
3. Get a complete list of doors from the DUT (see [Annex A.1](#)).
4. Check that there is at least one Door with Capabilities.DoubleLockMonitor = "true". Otherwise fail the test and skip other steps.
5. ONVIF Client will invoke **GetEventProperties** request to retrieve all events supported by the DUT.
6. Verify the **GetEventPropertiesResponse** message from the DUT.
7. Check if there is an event with Topic tns1:Door/State/DoubleLockPhysicalState. If there is no event with such Topic skip other steps, fail the test and go to the next test.
8. Check that this event is a Property event (MessageDescription.IsProperty = "true").
9. Check that this event contains Source.SimpleItemDescription item with Name = "DoorToken" and Type = "pt:ReferenceToken".
10. Check that this event contains Data.SimpleItemDescription item with Name = "State" and Type = "tdc:LockPhysicalState".
11. ONVIF Client will invoke **CreatePullPointSubscription** request with tns1:Door/State/DoubleLockPhysicalState Topic as Filter and an InitialTerminationTime of timeout1.
12. Verify that the DUT sends a **CreatePullPointSubscriptionResponse** message.
13. ONVIF Client will invoke PullMessages command with a PullMessagesTimeout of 20s and a MessageLimit of 1.
14. Verify that the DUT sends a **PullMessagesResponse** that contains NotificationMessages. Repeat step 13 until Notification for all Doors with Capabilities.DoorMonitor = "true" is received.
15. Verify received Notify messages (correct value for UTC time, TopicExpression and wsnt:Message).

16. Verify that TopicExpression is equal to tns1:Door/State/DoubleLockPhysicalState for all received Notify messages.
17. Verify that each notification contains Source.SimpleItem item with Name = "DoorToken" and Value is equal to one of existing Door Tokens Capabilities.DoubleLockMonitor = "true" (e.g. complete list of doors contains Door with the same token). Verify that there are Notification messages for each Door with Capabilities.DoubleLockMonitor = "true".
18. Verify that each notification contains Data.SimpleItem item with Name = "State" and Value with type is equal to tdc:LockPhysicalState.
19. Verify that Notify PropertyOperation = "Initialized".
20. ONVIF Client will invoke GetDoorState request for each Door with corresponding tokens.
21. Verify the **GetDoorStateResponse** messages from the DUT. Verify that Data.SimpleItem item with Name = "State" from Notification message has the same value with DoubleLockPhysicalState elements from corresponding **GetDoorStateResponse** messages for each Door with Capabilities.DoubleLockMonitor = "true".

**Test Result:****PASS –**

- DUT passes all assertions.

**FAIL –**

- The DUT did not send a **GetEventPropertiesResponse**
- The DUT did not send **CreatePullPointSubscriptionResponse** message.
- The DUT did not send **PullMessagesResponse** message.
- The DUT did not send valid SubscriptionReference.
- The DUT did not send a Notification message that contains a property event tns1:Door/State/DoubleLockPhysicalState at least for one Door with Capabilities.DoubleLockMonitor = "true".
- The DUT sent an invalid Notification message (no corresponding Source.SimpleItem or Data.SimpleItem, wrong type of Value fields, invalid DoorToken or State values, PropertyOperation is not equal to "Initialized").
- The DUT did not return at least one Door at step 3.
- The DUT did not return Topic tns1:Door/State/DoubleLockPhysicalState in **GetEventPropertiesResponse**.

**Note:** The Subscription Manager has to be deleted at the end of the test either by calling unsubscribe or through a timeout.

**Note:** ONVIF Client at step 14 will wait for Notification messages until notification for all Doors with Capabilities.DoubleLockMonitor = “true” is received or Operation Delay has expired. Notification messages for all Doors with Capabilities.DoubleLockMonitor = “true” are assumed as received, if the number of Notification messages is equal to the number of Doors with Capabilities.DoubleLockMonitor = “true”.

**Note:** If the DUT does not return any door for step 3, skip steps 4-21, fail the test and go to the next test.

**Note:** The Subscription Manager has to be deleted at the end of the test either by calling unsubscribe or through a timeout.

**Note:** The Renew has to be used for renew subscription during test, if InitialTerminationTime expires.

**Note:** If DUT cannot accept the set value to Timeout or MessageLimit, ONVIF Client retries to send the PullMessage message with Timeout and MessageLimit which is contained in PullMessagesFaultResponse.

**Note:** If DUT cannot accept the set value to a TerminationTime, ONVIF Client retries to send the Renew request MinimumTime value which is contained in UnacceptableTerminationTimeFault.

**Note:** timeout1 will be taken from Subscription Timeout field of ONVIF Device Test Tool.

## 4.5.5 DOOR CONTROL – DOUBLE LOCK PHYSICAL STATE EVENT STATE CHANGE

**Test Case ID:** DOORCONTROL-6-1-5

**Specification Coverage:** tns1:Door/State/DoubleLockPhysicalState (ONVIF Door Control Service Specification)

**Feature Under Test:** None

**WSDL Reference:** event.wsdl, doorcontrol.wsdl

**Test Purpose:** To verify tns1:Door/State/DoubleLockPhysicalState event generation after property was changed and to verify tns1:Door/State/DoubleLockPhysicalState event format.

**Pre-Requisite:** Event Service was received from the DUT. Door Control Service was received from the DUT. At least one Door with Double Lock Monitor capability is configured and added to the DUT.



**Test Configuration:** ONVIF Client and DUT**Test Procedure:**

1. Start an ONVIF Client.
2. Start the DUT.
3. Get a complete list of doors from the DUT (see [Annex A.1](#)).
4. Check that there is at least one Door with Capabilities.DoubleLockMonitor = "true". Otherwise fail the test and skip other steps.
5. ONVIF Client will select one first Door (token = Token1) with Capabilities.DoubleLockMonitor = "true".
6. ONVIF Client will invoke **CreatePullPointSubscription** request with tns1:Door/State/DoubleLockPhysicalState Topic as Filter and an InitialTerminationTime of timeout1.
7. Verify that the DUT sends a **CreatePullPointSubscriptionResponse** message.
8. Test Operator will invoke change of DoubleLockPhysicalState property for Door with token = Token1.
9. ONVIF Client will invoke **PullMessages** command with a PullMessagesTimeout of 20s and a MessageLimit of 1.
10. Verify that the DUT sends a **PullMessagesResponse** that contains NotificationMessages. Repeat step 9 until Notification with PropertyOperation = "Changed" for Door with Capabilities.DoubleLockMonitor = "true" is received.
11. Verify received Notify messages (correct value for UTC time, TopicExpression and wsnt:Message).
12. Verify that TopicExpression is equal to tns1:Door/State/DoubleLockPhysicalState for received Notify message.
13. Verify that notification contains Source.SimpleItem item with Name = "DoorToken" and Value = "Token1".
14. Verify that notification contains Data.SimpleItem item with Name = "State" and Value with type is equal to tdc:DoubleLockPhysicalState.

**Test Result:****PASS –**

- DUT passes all assertions.

**FAIL –**

- The DUT did not send **CreatePullPointSubscriptionResponse** message.
- The DUT did not send **PullMessagesResponse** message.
- The DUT did not send valid SubscriptionReference.
- The DUT did not send a Notification message that contains a property event tns1:Door/State/DoubleLockPhysicalState with valid DoorToken.
- The DUT sent an invalid Notification message (no corresponding Source.SimpleItem or Data.SimpleItem, wrong type of Value fields, invalid DoorToken value).
- The DUT did not return at least one Door at step 3.

**Note:** The Subscription Manager has to be deleted at the end of the test either by calling unsubscribe or through a timeout.

**Note:** All Notification messages except messages with PropertyOperation = "Changed" will be ignored.

**Note:** Test will be failed, if no required Notification messages are received for step 10 during a certain period of time (Operation Delay should be used in ONVIF Device Test Tool).

**Note:** If the DUT does not return any door for step 3, skip steps 4-14, fail the test and go to the next test.

**Note:** The Subscription Manager has to be deleted at the end of the test either by calling unsubscribe or through a timeout.

**Note:** The Renew has to be used for renew subscription during test, if InitialTerminationTime expires.

**Note:** If DUT cannot accept the set value to Timeout or MessageLimit, ONVIF Client retries to send the PullMessage message with Timeout and MessageLimit which is contained in PullMessagesFaultResponse.

**Note:** If DUT cannot accept the set value to a TerminationTime, ONVIF Client retries to send the Renew request MinimumTime value which is contained in UnacceptableTerminationTimeFault.

**Note:** timeout1 will be taken from Subscription Timeout field of ONVIF Device Test Tool.

## 4.5.6 DOOR CONTROL – LOCK PHYSICAL STATE EVENT

**Test Case ID:** DOORCONTROL-6-1-6

**Specification Coverage:** tns1:Door/State/LockPhysicalState (ONVIF Door Control Service Specification), GetDoorState (ONVIF Door Control Service Specification), Properties (ONVIF Core Specification)

**Feature Under Test:** GetDoorState

**WSDL Reference:** event.wsdl, doorcontrol.wsdl

**Test Purpose:** To verify tns1:Door/State/LockPhysicalState event generation after subscription and to verify tns1:Door/State/LockPhysicalState event format.

**Pre-Requirement:** Event Service was received from the DUT. Door Control Service was received from the DUT. At least one Door with Lock Monitor capability is configured and added to the DUT.

**Test Configuration:** ONVIF Client and DUT

**Test Procedure:**

1. Start an ONVIF Client.
2. Start the DUT.
3. Get a complete list of doors from the DUT (see [Annex A.1](#)).
4. Check that there is at least one Door with Capabilities.LockMonitor = "true". Otherwise fail the test and skip other steps.
5. ONVIF Client will invoke **GetEventProperties** request to retrieve all events supported by the DUT.
6. Verify the **GetEventPropertiesResponse** message from the DUT.
7. Check if there is an event with Topic tns1:Door/State/LockPhysicalState. If there is no event with such Topic skip other steps, fail the test and go to the next test.
8. Check that this event is a Property event (MessageDescription.IsProperty = "true").
9. Check that this event contains Source.SimpleItemDescription item with Name = "DoorToken" and Type = "pt:ReferenceToken".
10. Check that this event contains Data.SimpleItemDescription item with Name = "State" and Type = "tdc:LockPhysicalState".
11. ONVIF Client will invoke **CreatePullPointSubscription** request with tns1:Door/State/LockPhysicalState Topic as Filter and an InitialTerminationTime of timeout1.
12. Verify that the DUT sends a **CreatePullPointSubscriptionResponse** message.

13. ONVIF Client will invoke **PullMessages** command with a PullMessagesTimeout of 20s and a MessageLimit of 1.
14. Verify that the DUT sends a **PullMessagesResponse** that contains NotificationMessages. Repeat step 13 until Notification for all Doors with Capabilities.DoorMonitor = "true" is received.
15. Verify received Notify messages (correct value for UTC time, TopicExpression and wsnt:Message).
16. Verify that TopicExpression is equal to tns1:Door/State/LockPhysicalState for all received Notify messages.
17. Verify that each notification contains Source.SimpleItem item with Name = "DoorToken" and Value is equal to one of existing Door Tokens Capabilities.LockMonitor = "true" (e.g. complete list of doors contains Door with the same token). Verify that there are Notification messages for each Door with Capabilities.LockMonitor = "true".
18. Verify that each notification contains Data.SimpleItem item with Name = "State" and Value with type is equal to tdc:LockPhysicalState.
19. Verify that Notify PropertyOperation = "Initialized".
20. ONVIF Client will invoke **GetDoorState** request for each Door with corresponding tokens.
21. Verify the **GetDoorStateResponse** messages from the DUT. Verify that Data.SimpleItem item with Name = "State" from Notification message has the same value with LockPhysicalState elements from corresponding **GetDoorStateResponse** messages for each Door with Capabilities.LockMonitor = "true".

**Test Result:****PASS –**

- DUT passes all assertions.

**FAIL –**

- The DUT did not send a **GetEventPropertiesResponse**
- The DUT did not send **CreatePullPointSubscriptionResponse** message.
- The DUT did not send **PullMessagesResponse** message.
- The DUT did not send valid **SubscriptionReference**.
- The DUT did not send a Notification message that contains a property event tns1:Door/State/LockPhysicalState at least for one Door with Capabilities.LockMonitor = "true".

- The DUT sent an invalid Notification message (no corresponding Source.SimpleItem or Data.SimpleItem, wrong type of Value fields, invalid DoorToken or State values, PropertyOperation is not equal to "Initialized").
- The DUT did not return at least one Door at step 3.
- The DUT did not return Topic tns1:Door/State/LockPhysicalState in **GetEventPropertiesResponse**.

**Note:** The Subscription Manager has to be deleted at the end of the test either by calling unsubscribe or through a timeout.

**Note:** ONVIF Client at step 14 will wait for Notification messages until notification for all Doors with Capabilities.LockMonitor = "true" is received or Operation Delay has expired. Notification messages for all Doors with Capabilities.LockMonitor = "true" are assumed as received, if the number of Notification messages is equal to the number of Doors with Capabilities.LockMonitor = "true".

**Note:** If the DUT does not return any door for step 3, skip steps 4-21, fail the test and go to the next test.

**Note:** The Subscription Manager has to be deleted at the end of the test either by calling unsubscribe or through a timeout.

**Note:** The Renew has to be used for renew subscription during test, if InitialTerminationTime expires.

**Note:** If DUT cannot accept the set value to Timeout or MessageLimit, ONVIF Client retries to send the PullMessage message with Timeout and MessageLimit which is contained in PullMessagesFaultResponse.

**Note:** If DUT cannot accept the set value to a TerminationTime, ONVIF Client retries to send the Renew request MinimumTime value which is contained in UnacceptableTerminationTimeFault.

**Note:** timeout1 will be taken from Subscription Timeout field of ONVIF Device Test Tool.

## 4.5.7 DOOR CONTROL – LOCK PHYSICAL STATE EVENT STATE CHANGE

**Test Case ID:** DOORCONTROL-6-1-7

**Specification Coverage:** tns1:Door/State/LockPhysicalState (ONVIF Door Control Service Specification)

**Feature Under Test:** None

**WSDL Reference:** event.wsdl, doorcontrol.wsdl

**Test Purpose:** To verify tns1:Door/State/LockPhysicalState event generation after property was changed and to verify tns1:Door/State/LockPhysicalState event format.

**Pre-Requirement:** Event Service was received from the DUT. Door Control Service was received from the DUT. At least one Door with Lock Monitor capability is configured and added to the DUT.

**Test Configuration:** ONVIF Client and DUT

**Test Procedure:**

1. Start an ONVIF Client.
2. Start the DUT.
3. Get a complete list of doors from the DUT (see [Annex A.1](#)).
4. Check that there is at least one Door with Capabilities.LockMonitor = "true". Otherwise, fail the test and skip other steps.
5. ONVIF Client will select one first Door (token = Token1) with Capabilities.LockMonitor = "true".
6. ONVIF Client will invoke **CreatePullPointSubscription** request with tns1:Door/State/LockPhysicalState Topic as Filter and an InitialTerminationTime of timeout1.
7. Verify that the DUT sends a **CreatePullPointSubscriptionResponse** message.
8. Test Operator will invoke change of LockPhysicalState property for Door with token = Token1.
9. ONVIF Client will invoke **PullMessages** command with a PullMessagesTimeout of 20s and a MessageLimit of 1.
10. Verify that the DUT sends a **PullMessagesResponse** that contains NotificationMessages. Repeat step 9 until Notification with PropertyOperation = "Changed" for Door with Capabilities.LockMonitor = "true" is received.
11. Verify received Notify messages (correct value for UTC time, TopicExpression and wsnt:Message).
12. Verify that TopicExpression is equal to tns1:Door/State/LockPhysicalState for received Notify message.
13. Verify that notification contains Source.SimpleItem item with Name = "DoorToken" and Value = "Token1".

14. Verify that notification contains Data.SimpleItem item with Name = "State" and Value with type is equal to tdc:LockPhysicalState.

**Test Result:****PASS –**

- DUT passes all assertions.

**FAIL –**

- The DUT did not send **CreatePullPointSubscriptionResponse** message.
- The DUT did not send **PullMessagesResponse** message.
- The DUT did not send valid SubscriptionReference.
- The DUT did not send a Notification message that contains a property event tns1:Door/State/LockPhysicalState with valid DoorToken.
- The DUT sent an invalid Notification message (no corresponding Source.SimpleItem or Data.SimpleItem, wrong type of Value fields, invalid DoorToken value).
- The DUT did not return at least one Door at step 3.

**Note:** The Subscription Manager has to be deleted at the end of the test either by calling unsubscribe or through a timeout.

**Note:** All Notification messages except messages with PropertyOperation = "Changed" will be ignored.

**Note:** Test will be failed, if no required Notification messages are received for step 10 during a certain period of time (Operation Delay should be used in ONVIF Device Test Tool).

**Note:** If the DUT does not return any door for step 3, skip steps 4-14, fail the test and go to the next test.

**Note:** The Subscription Manager has to be deleted at the end of the test either by calling unsubscribe or through a timeout.

**Note:** The Renew has to be used for renew subscription during test, if InitialTerminationTime expires.

**Note:** If DUT cannot accept the set value to Timeout or MessageLimit, ONVIF Client retries to send the PullMessage message with Timeout and MessageLimit which is contained in PullMessagesFaultResponse.

**Note:** If DUT cannot accept the set value to a TerminationTime, ONVIF Client retries to send the Renew request MinimumTime value which is contained in UnacceptableTerminationTimeFault.

**Note:** timeout1 will be taken from Subscription Timeout field of ONVIF Device Test Tool.

## 4.5.8 DOOR CONTROL – DOOR TAMPER EVENT

**Test Case ID:** DOORCONTROL-6-1-8

**Specification Coverage:** tns1:Door/State/DoorTamper (ONVIF Door Control Service Specification), GetDoorState (ONVIF Door Control Service Specification), Properties (ONVIF Core Specification)

**Feature Under Test:** GetDoorState

**WSDL Reference:** event.wSDL, doorcontrol.wSDL

**Test Purpose:** To verify tns1:Door/State/DoorTamper event generation after subscription and to verify tns1:Door/State/DoorTamper event format.

**Pre-Requisite:** Event Service was received from the DUT. Door Control Service was received from the DUT. At least one Door with Tamper capability is configured and added to the DUT.

**Test Configuration:** ONVIF Client and DUT

**Test Procedure:**

1. Start an ONVIF Client.
2. Start the DUT.
3. Get a complete list of doors from the DUT (see [Annex A.1](#)).
4. Check that there is at least one Door with Capabilities.Tamper = "true". Otherwise fail the test and skip other steps.
5. ONVIF Client will invoke **GetEventProperties** request to retrieve all events supported by the DUT.
6. Verify the **GetEventPropertiesResponse** message from the DUT.
7. Check if there is an event with Topic tns1:Door/State/DoorTamper. If there is no event with such Topic skip other steps, fail the test and go to the next test.
8. Check that this event is a Property event (MessageDescription.IsProperty = "true").



9. Check that this event contains Source.SimpleItemDescription item with Name = "DoorToken" and Type = "pt:ReferenceToken".
10. Check that this event contains Data.SimpleItemDescription item with Name = "State" and Type = "tdc:DoorTamperState".
11. ONVIF Client will invoke **CreatePullPointSubscription** request with tns1:Door/State/DoorTamper Topic as Filter and an InitialTerminationTime of timeout1.
12. Verify that the DUT sends a **CreatePullPointSubscriptionResponse** message.
13. ONVIF Client will invoke **PullMessages** command with a PullMessagesTimeout of 20s and a MessageLimit of 1.
14. Verify that the DUT sends a **PullMessagesResponse** that contains NotificationMessages. Repeat step 13 until Notification for all Doors with Capabilities.DoorMonitor = "true" is received.
15. Verify received Notify messages (correct value for UTC time, TopicExpression and wsnt:Message).
16. Verify that TopicExpression is equal to tns1:Door/State/DoorTamper for all received Notify messages.
17. Verify that each notification contains Source.SimpleItem item with Name = "DoorToken" and Value is equal to one of existing Door Tokens Capabilities.Tamper = "true" (e.g. complete list of doors contains Door with the same token). Verify that there are Notification messages for each Door with Capabilities.Tamper = "true".
18. Verify that each notification contains Data.SimpleItem item with Name = "State" and Value with type is equal to tdc:DoorTamperState.
19. Verify that Notify PropertyOperation = "Initialized".
20. ONVIF Client will invoke **GetDoorState** request for each Door with corresponding tokens.
21. Verify the **GetDoorStateResponse** messages from the DUT. Verify that Data.SimpleItem item with Name = "State" from Notification message has the same value with Tamper elements from corresponding **GetDoorStateResponse** messages for each Door with Capabilities.Tamper = "true".

**Test Result:****PASS –**

- DUT passes all assertions.

**FAIL –**

- The DUT did not send a **GetEventPropertiesResponse**
- The DUT did not send **CreatePullPointSubscriptionResponse** message.
- The DUT did not send **PullMessagesResponse** message.
- The DUT did not send valid SubscriptionReference.
- The DUT did not send a Notification message that contains a property event tns1:Door/State/DoorTamper at least for one Door with Capabilities.Tamper = “true”.
- The DUT sent an invalid Notification message (no corresponding Source.SimpleItem or Data.SimpleItem, wrong type of Value fields, invalid DoorToken or State values, PropertyOperation is not equal to "Initialized").
- The DUT did not return at least one Door at step 3.
- The DUT did not return Topic tns1:Door/State/DoorTamper in **GetEventPropertiesResponse**.

**Note:** The Subscription Manager has to be deleted at the end of the test either by calling unsubscribe or through a timeout.

**Note:** ONVIF Client at step 14 will wait for Notification messages until notification for all Doors with Capabilities.Tamper = “true” is received or Operation Delay has expired. Notification messages for all Doors with Capabilities.Tamper = “true” are assumed as received, if the number of Notification messages is equal to the number of Doors with Capabilities.Tamper = “true”.

**Note:** If the DUT does not return any door for step 3, skip steps 4-21, fail the test and go to the next test.

**Note:** The Subscription Manager has to be deleted at the end of the test either by calling unsubscribe or through a timeout.

**Note:** The Renew has to be used for renew subscription during test, if InitialTerminationTime expires.

**Note:** If DUT cannot accept the set value to Timeout or MessageLimit, ONVIF Client retries to send the PullMessage message with Timeout and MessageLimit which is contained in PullMessagesFaultResponse.

**Note:** If DUT cannot accept the set value to a TerminationTime, ONVIF Client retries to send the Renew request MinimumTime value which is contained in UnacceptableTerminationTimeFault.

**Note:** timeout1 will be taken from Subscription Timeout field of ONVIF Device Test Tool.

## 4.5.9 DOOR CONTROL – DOOR TAMPER EVENT STATE CHANGE

**Test Case ID:** DOORCONTROL-6-1-9

**Specification Coverage:** tns1:Door/State/DoorTamper (ONVIF Door Control Service Specification)

**Feature Under Test:** None

**WSDL Reference:** event.wsdl, doorcontrol.wsdl

**Test Purpose:** To verify tns1:Door/State/DoorTamper event generation after property was changed and to verify tns1:Door/State/DoorTamper event format.

**Pre-Requirement:** Event Service was received from the DUT. Door Control Service was received from the DUT. At least one Door with Tamper capability is configured and added to the DUT.

**Test Configuration:** ONVIF Client and DUT

**Test Procedure:**

1. Start an ONVIF Client.
2. Start the DUT.
3. Get a complete list of doors from the DUT (see [Annex A.1](#)).
4. Check that there is at least one Door with Capabilities.Tamper = "true". Otherwise fail the test and skip other steps.
5. ONVIF Client will select one first Door (token = Token1) with Capabilities.Tamper = "true".
6. ONVIF Client will invoke **CreatePullPointSubscription** request with tns1:Door/State/DoorTamper Topic as Filter and an InitialTerminationTime of timeout1.
7. Verify that the DUT sends a **CreatePullPointSubscriptionResponse** message.
8. Test Operator will invoke change of DoorTamper property for Door with token = Token1.
9. ONVIF Client will invoke **PullMessages** command with a PullMessagesTimeout of 20s and a MessageLimit of 1.
10. Verify that the DUT sends a **PullMessagesResponse** that contains NotificationMessages. Repeat step 9 until Notification with PropertyOperation = "Changed" for Door with Capabilities.Tamper = "true" is received.

11. Verify received Notify messages (correct value for UTC time, TopicExpression and wsnt:Message).
12. Verify that TopicExpression is equal to tns1:Door/State/DoorTamper for received Notify message.
13. Verify that notification contains Source.SimpleItem item with Name = "DoorToken" and Value = "Token1".
14. Verify that notification contains Data.SimpleItem item with Name = "State" and Value with type is equal to tdc:DoorTamperState.

**Test Result:****PASS –**

- DUT passes all assertions.

**FAIL –**

- The DUT did not send **CreatePullPointSubscriptionResponse** message.
- The DUT did not send **PullMessagesResponse** message.
- The DUT did not send valid SubscriptionReference.
- The DUT did not send a Notification message that contains a property event tns1:Door/State/DoorTamper with valid DoorToken.
- The DUT sent an invalid Notification message (no corresponding Source.SimpleItem or Data.SimpleItem, wrong type of Value fields, invalid DoorToken value).
- The DUT did not return at least one Door at step 3.

**Note:** The Subscription Manager has to be deleted at the end of the test either by calling unsubscribe or through a timeout.

**Note:** All Notification messages except messages with PropertyOperation = "Changed" will be ignored.

**Note:** Test will be failed, if no required Notification messages are received for step 10 during a certain period of time (Operation Delay should be used in ONVIF Device Test Tool).

**Note:** If the DUT does not return any door for step 3, skip steps 4-14, fail the test and go to the next test.

**Note:** The Subscription Manager has to be deleted at the end of the test either by calling unsubscribe or through a timeout.

**Note:** The Renew has to be used for renew subscription during test, if InitialTerminationTime expires.

**Note:** If DUT cannot accept the set value to Timeout or MessageLimit, ONVIF Client retries to send the PullMessage message with Timeout and MessageLimit which is contained in PullMessagesFaultResponse.

**Note:** If DUT cannot accept the set value to a TerminationTime, ONVIF Client retries to send the Renew request MinimumTime value which is contained in UnacceptableTerminationTimeFault.

**Note:** timeout1 will be taken from Subscription Timeout field of ONVIF Device Test Tool.

## 4.5.10 DOOR CONTROL – DOOR ALARM EVENT

**Test Case ID:** DOORCONTROL-6-1-10

**Specification Coverage:** tns1:Door/State/DoorAlarm (ONVIF Door Control Service Specification), GetDoorState (ONVIF Door Control Service Specification), Properties (ONVIF Core Specification)

**Feature Under Test:** GetDoorState

**WSDL Reference:** event.wsdl, doorcontrol.wsdl

**Test Purpose:** To verify tns1:Door/State/DoorAlarm event generation after subscription and to verify tns1:Door/State/DoorAlarm event format.

**Pre-Requisite:** Event Service was received from the DUT. Door Control Service was received from the DUT. At least one Door with Alarm capability is configured and added to the DUT.

**Test Configuration:** ONVIF Client and DUT

**Test Procedure:**

1. Start an ONVIF Client.
2. Start the DUT.
3. Get a complete list of doors from the DUT (see [Annex A.1](#)).
4. Check that there is at least one Door with Capabilities.Alarm = “true”. Otherwise fail the test and skip other steps.
5. ONVIF Client will invoke **GetEventProperties** request to retrieve all events supported by the DUT.
6. Verify the **GetEventPropertiesResponse** message from the DUT.

7. Check if there is an event with Topic `tns1:Door/State/DoorAlarm`. If there is no event with such Topic skip other steps, fail the test and go to the next test.
8. Check that this event is a Property event (`MessageDescription.IsProperty = "true"`).
9. Check that this event contains `Source.SimpleItemDescription` item with `Name = "DoorToken"` and `Type = "pt:ReferenceToken"`.
10. Check that this event contains `Data.SimpleItemDescription` item with `Name = "State"` and `Type = "tdc:DoorAlarmState"`.
11. ONVIF Client will invoke **CreatePullPointSubscription** request with `tns1:Door/State/DoorAlarm` Topic as Filter and an `InitialTerminationTime` of `timeout1`.
12. Verify that the DUT sends a **CreatePullPointSubscriptionResponse** message.
13. ONVIF Client will invoke **PullMessages** command with a `PullMessagesTimeout` of 20s and a `MessageLimit` of 1.
14. Verify that the DUT sends a **PullMessagesResponse** that contains `NotificationMessages`. Repeat step 13 until Notification for all Doors with `Capabilities.DoorMonitor = "true"` is received.
15. Verify received Notify messages (correct value for UTC time, `TopicExpression` and `wsnt:Message`).
16. Verify that `TopicExpression` is equal to `tns1:Door/State/DoorAlarm` for all received Notify messages.
17. Verify that each notification contains `Source.SimpleItem` item with `Name = "DoorToken"` and `Value` is equal to one of existing Door Tokens `Capabilities.Alarm = "true"` (e.g. complete list of doors contains Door with the same token). Verify that there are Notification messages for each Door with `Capabilities.Alarm = "true"`.
18. Verify that each notification contains `Data.SimpleItem` item with `Name = "State"` and `Value` with type is equal to `tdc:DoorAlarmState`.
19. Verify that `Notify PropertyOperation = "Initialized"`.
20. ONVIF Client will invoke **GetDoorState** request for each Door with corresponding tokens.
21. Verify the **GetDoorStateResponse** messages from the DUT. Verify that `Data.SimpleItem` item with `Name = "State"` from Notification message has the same value with Alarm elements from corresponding **GetDoorStateResponse** messages for each Door with `Capabilities.Alarm = "true"`.

**Test Result:****PASS –**

- DUT passes all assertions.

**FAIL –**

- The DUT did not send a **GetEventPropertiesResponse**
- The DUT did not send **CreatePullPointSubscriptionResponse** message.
- The DUT did not send **PullMessagesResponse** message.
- The DUT did not send valid SubscriptionReference.
- The DUT did not send a Notification message that contains a property event tns1:Door/State/DoorAlarm at least for one Door with Capabilities.Alarm = “true”.
- The DUT sent an invalid Notification message (no corresponding Source.SimpleItem or Data.SimpleItem, wrong type of Value fields, invalid DoorToken or State values, PropertyOperation is not equal to "Initialized").
- The DUT did not return at least one Door at step 3.
- The DUT did not return Topic tns1:Door/State/DoorAlarm in **GetEventPropertiesResponse**.

**Note:** The Subscription Manager has to be deleted at the end of the test either by calling unsubscribe or through a timeout.

**Note:** ONVIF Client at step 14 will wait for Notification messages until notification for all Doors with Capabilities.Alarm = “true” is received or Operation Delay has expired. Notification messages for all Doors with Capabilities.Alarm = “true” are assumed as received, if the number of Notification messages is equal to the number of Doors with Capabilities.Alarm = “true”.

**Note:** If the DUT does not return any door for step 3, skip steps 4-21, fail the test and go to the next test.

**Note:** The Subscription Manager has to be deleted at the end of the test either by calling unsubscribe or through a timeout.

**Note:** The Renew has to be used for renew subscription during test, if InitialTerminationTime expires.

**Note:** If DUT cannot accept the set value to Timeout or MessageLimit, ONVIF Client retries to send the PullMessage message with Timeout and MessageLimit which is contained in PullMessagesFaultResponse.

**Note:** If DUT cannot accept the set value to a TerminationTime, ONVIF Client retries to send the Renew request MinimumTime value which is contained in UnacceptableTerminationTimeFault.

**Note:** timeout1 will be taken from Subscription Timeout field of ONVIF Device Test Tool.

## 4.5.11 DOOR CONTROL – DOOR ALARM EVENT STATE CHANGE

**Test Case ID:** DOORCONTROL-6-1-11

**Specification Coverage:** tns1:Door/State/DoorAlarm (ONVIF Door Control Service Specification)

**Feature Under Test:** None

**WSDL Reference:** event.wsdl, doorcontrol.wsdl

**Test Purpose:** To verify tns1:Door/State/DoorAlarm event generation after property was changed and to verify tns1:Door/State/DoorAlarm event format.

**Pre-Requisite:** Event Service was received from the DUT. Door Control Service was received from the DUT. At least one Door with Alarm capability is configured and added to the DUT.

**Test Configuration:** ONVIF Client and DUT

**Test Procedure:**

1. Start an ONVIF Client.
2. Start the DUT.
3. Get a complete list of doors from the DUT (see [Annex A.1](#)).
4. Check that there is at least one Door with Capabilities.Alarm = "true". Otherwise fail the test and skip other steps.
5. ONVIF Client will select one first Door (token = Token1) with Capabilities.Alarm = "true".
6. ONVIF Client will invoke **CreatePullPointSubscription** request with tns1:Door/State/DoorAlarm Topic as Filter and an InitialTerminationTime of timeout1.
7. Verify that the DUT sends a **CreatePullPointSubscriptionResponse** message.
8. Test Operator will invoke change of DoorAlarm property for Door with token = Token1.
9. ONVIF Client will invoke **PullMessages** command with a PullMessagesTimeout of 20s and a MessageLimit of 1.



10. Verify that the DUT sends a **PullMessagesResponse** that contains NotificationMessages. Repeat step 9 until Notification with PropertyOperation = "Changed" for Door with Capabilities.Alarm = "true" is received.
11. Verify received Notify messages (correct value for UTC time, TopicExpression and wsnt:Message).
12. Verify that TopicExpression is equal to tns1:Door/State/DoorAlarm for received Notify message.
13. Verify that notification contains Source.SimpleItem item with Name = "DoorToken" and Value = "Token1".
14. Verify that notification contains Data.SimpleItem item with Name = "State" and Value with type is equal to tdc:DoorAlarmState.

**Test Result:****PASS –**

- DUT passes all assertions.

**FAIL –**

- The DUT did not send **CreatePullPointSubscriptionResponse** message.
- The DUT did not send **PullMessagesResponse** message.
- The DUT did not send valid **SubscriptionReference**.
- The DUT did not send a Notification message that contains a property event tns1:Door/State/DoorAlarm with valid DoorToken.
- The DUT sent an invalid Notification message (no corresponding Source.SimpleItem or Data.SimpleItem, wrong type of Value fields, invalid DoorToken value).
- The DUT did not return at least one Door at step 3.

**Note:** The Subscription Manager has to be deleted at the end of the test either by calling unsubscribe or through a timeout.

**Note:** All Notification messages except messages with PropertyOperation = "Changed" will be ignored.

**Note:** Test will be failed, if no required Notification messages are received for step 10 during a certain period of time (Operation Delay should be used in ONVIF Device Test Tool).

**Note:** If the DUT does not return any door for step 3, skip steps 4-14, fail the test and go to the next test.

**Note:** The Subscription Manager has to be deleted at the end of the test either by calling unsubscribe or through a timeout.

**Note:** The Renew has to be used for renew subscription during test, if InitialTerminationTime expires.

**Note:** If DUT cannot accept the set value to Timeout or MessageLimit, ONVIF Client retries to send the PullMessage message with Timeout and MessageLimit which is contained in PullMessagesFaultResponse.

**Note:** If DUT cannot accept the set value to a TerminationTime, ONVIF Client retries to send the Renew request MinimumTime value which is contained in UnacceptableTerminationTimeFault.

**Note:** timeout1 will be taken from Subscription Timeout field of ONVIF Device Test Tool.

## 4.5.12 DOOR CONTROL – DOOR FAULT EVENT

**Test Case ID:** DOORCONTROL-6-1-12

**Specification Coverage:** tns1:Door/State/DoorFault (ONVIF Door Control Service Specification), GetDoorState (ONVIF Door Control Service Specification), Properties (ONVIF Core Specification)

**Feature Under Test:** GetDoorState

**WSDL Reference:** event.wsdl, doorcontrol.wsdl

**Test Purpose:** To verify tns1:Door/State/DoorFault event generation after subscription and to verify tns1:Door/State/DoorFault event format.

**Pre-Requisite:** Event Service was received from the DUT. Door Control Service was received from the DUT. At least one Door with Fault capability is configured and added to the DUT.

**Test Configuration:** ONVIF Client and DUT

**Test Procedure:**

1. Start an ONVIF Client.
2. Start the DUT.
3. Get a complete list of doors from the DUT (see [Annex A.1](#)).
4. Check that there is at least one Door with Capabilities.Fault = “true”. Otherwise fail the test and skip other steps.

5. ONVIF Client will invoke **GetEventProperties** request to retrieve all events supported by the DUT.
6. Verify the **GetEventPropertiesResponse** message from the DUT.
7. Check if there is an event with Topic tns1:Door/State/DoorFault. If there is no event with such Topic skip other steps, fail the test and go to the next test.
8. Check that this event is a Property event (MessageDescription.IsProperty = "true").
9. Check that this event contains Source.SimpleItemDescription item with Name = "DoorToken" and Type = "pt:ReferenceToken".
10. Check that this event contains Data.SimpleItemDescription item with Name = "State" and Type = "tdc:DoorFaultState".
11. Check that this event contains Data.SimpleItemDescription item with Name = "Reason" and Type = "xs:string".
12. ONVIF Client will invoke **CreatePullPointSubscription** request with tns1:Door/State/DoorFault Topic as Filter and an InitialTerminationTime of timeout1.
13. Verify that the DUT sends a **CreatePullPointSubscriptionResponse** message.
14. ONVIF Client will invoke **PullMessages** command with a PullMessagesTimeout of 20s and a MessageLimit of 1.
15. Verify that the DUT sends a **PullMessagesResponse** that contains NotificationMessages. Repeat step 14 until Notification for all Doors with Capabilities.DoorMonitor = "true" is received.
16. Verify received Notify messages (correct value for UTC time, TopicExpression and wsnt:Message).
17. Verify that TopicExpression is equal to tns1:Door/State/DoorFault for all received Notify messages.
18. Verify that each notification contains Source.SimpleItem item with Name = "DoorToken" and Value is equal to one of existing Door Tokens Capabilities.Fault = "true" (e.g. complete list of doors contains Door with the same token). Verify that there are Notification messages for each Door with Capabilities.Fault = "true".
19. Verify that each notification contains Data.SimpleItem item with Name = "State" and Value with type is equal to tdc:DoorFaultState.
20. Verify that each notification which contains Data.SimpleItem item with Name = "Reason" has Value with type is equal to xs:string.

21. Verify that Notify PropertyOperation = "Initialized".
22. ONVIF Client will invoke **GetDoorState** request for each Door with corresponding tokens.
23. Verify the **GetDoorStateResponse** messages from the DUT. Verify that Data.SimpleItem item with Name = "State" from Notification message has the same value with Fault elements from corresponding **GetDoorStateResponse** messages for each Door with Capabilities.Fault = "true".

**Test Result:****PASS –**

- DUT passes all assertions.

**FAIL –**

- The DUT did not send a **GetEventPropertiesResponse**
- The DUT did not send **CreatePullPointSubscriptionResponse** message.
- The DUT did not send **PullMessagesResponse** message.
- The DUT did not send valid SubscriptionReference.
- The DUT did not send a Notification message that contains a property event tns1:Door/State/DoorFault at least for one Door with Capabilities.Fault = "true".
- The DUT sent an invalid Notification message (no corresponding Source.SimpleItem or Data.SimpleItem, wrong type of Value fields, invalid DoorToken, Reason or State values, PropertyOperation is not equal to "Initialized").
- The DUT did not return at least one Door at step 3.
- The DUT did not return Topic tns1:Door/State/DoorFault in **GetEventPropertiesResponse**.

**Note:** The Subscription Manager has to be deleted at the end of the test either by calling unsubscribe or through a timeout.

**Note:** ONVIF Client at step 15 will wait for Notification messages until notification for all Doors with Capabilities.Fault = "true" is received or Operation Delay has expired. Notification messages for all Doors with Capabilities.Fault = "true" are assumed as received, if the number of Notification messages is equal to the number of Doors with Capabilities.Fault = "true".

**Note:** If the DUT does not return any door for step 3, skip steps 4-23, fail the test and go to the next test.

**Note:** The Subscription Manager has to be deleted at the end of the test either by calling unsubscribe or through a timeout.

**Note:** The Renew has to be used for renew subscription during test, if InitialTerminationTime expires.

**Note:** If DUT cannot accept the set value to Timeout or MessageLimit, ONVIF Client retries to send the PullMessage message with Timeout and MessageLimit which is contained in PullMessagesFaultResponse.

**Note:** If DUT cannot accept the set value to a TerminationTime, ONVIF Client retries to send the Renew request MinimumTime value which is contained in UnacceptableTerminationTimeFault.

**Note:** timeout1 will be taken from Subscription Timeout field of ONVIF Device Test Tool.

## 4.5.13 DOOR CONTROL – DOOR FAULT EVENT STATE CHANGE

**Test Case ID:** DOORCONTROL-6-1-13

**Specification Coverage:** tns1:Door/State/DoorFault (ONVIF Door Control Service Specification)

**Feature Under Test:** None

**WSDL Reference:** event.wSDL, doorcontrol.wSDL

**Test Purpose:** To verify tns1:Door/State/DoorFault event generation after property was changed and to verify tns1:Door/State/DoorFault event format.

**Pre-Requisite:** Event Service was received from the DUT. Door Control Service was received from the DUT. At least one Door with Fault capability is configured and added to the DUT.

**Test Configuration:** ONVIF Client and DUT

**Test Procedure:**

1. Start an ONVIF Client.
2. Start the DUT.
3. Get a complete list of doors from the DUT (see [Annex A.1](#)).
4. Check that there is at least one Door with Capabilities.Fault = "true". Otherwise, fail the test and skip other steps.
5. ONVIF Client will select one first Door (token = Token1) with Capabilities.Fault = "true".

6. ONVIF Client will invoke **CreatePullPointSubscription** request with `tns1:Door/State/DoorFault` Topic as Filter and an `InitialTerminationTime` of `timeout1`.
7. Verify that the DUT sends a **CreatePullPointSubscriptionResponse** message.
8. Test Operator will invoke change of `DoorFault` property for `Door` with `token = Token1`.
9. ONVIF Client will invoke **PullMessages** command with a `PullMessagesTimeout` of 20s and a `MessageLimit` of 1.
10. Verify that the DUT sends a **PullMessagesResponse** that contains `NotificationMessages`. Repeat step 9 until Notification with `PropertyOperation = "Changed"` for `Door` with `Capabilities.Fault = "true"` is received.
11. Verify received Notify messages (correct value for UTC time, `TopicExpression` and `wsnt:Message`).
12. Verify that `TopicExpression` is equal to `tns1:Door/State/DoorFault` for received Notify message.
13. Verify that notification contains `Source.SimpleItem` item with `Name = "DoorToken"` and `Value = "Token1"`.
14. Verify that notification contains `Data.SimpleItem` item with `Name = "State"` and `Value` with type is equal to `tdc:DoorFaultState`.
15. Verify that notification contains `Data.SimpleItem` item with `Name = "Reason"` and `Value` with type is equal to `xs:string`.

#### Test Result:

##### PASS –

- DUT passes all assertions.

##### FAIL –

- The DUT did not send **CreatePullPointSubscriptionResponse** message.
- The DUT did not send **PullMessagesResponse** message.
- The DUT did not send valid `SubscriptionReference`.
- The DUT did not send a Notification message that contains a property event `tns1:Door/State/DoorFault` with valid `DoorToken`.
- The DUT sent an invalid Notification message (no corresponding `Source.SimpleItem` or `Data.SimpleItem`, wrong type of `Value` fields, invalid `DoorToken` value).

- The DUT did not return at least one Door at step 3.

**Note:** The Subscription Manager has to be deleted at the end of the test either by calling unsubscribe or through a timeout.

**Note:** All Notification messages except messages with PropertyOperation = "Changed" will be ignored.

**Note:** Test will be failed, if no required Notification messages are received for step 10 during a certain period of time (Operation Delay should be used in ONVIF Device Test Tool).

**Note:** If the DUT does not return any door for step 3, skip steps 4-15, fail the test and go to the next test.

**Note:** The Subscription Manager has to be deleted at the end of the test either by calling unsubscribe or through a timeout.

**Note:** The Renew has to be used for renew subscription during test, if InitialTerminationTime expires.

**Note:** If DUT cannot accept the set value to Timeout or MessageLimit, ONVIF Client retries to send the PullMessage message with Timeout and MessageLimit which is contained in PullMessagesFaultResponse.

**Note:** If DUT cannot accept the set value to a TerminationTime, ONVIF Client retries to send the Renew request MinimumTime value which is contained in UnacceptableTerminationTimeFault.

**Note:** timeout1 will be taken from Subscription Timeout field of ONVIF Device Test Tool.

## 4.6 Door Configuration

### 4.6.1 DOOR CONTROL – ADD OR CHANGE DOOR EVENT

**Test Case ID:** DOORCONTROL-7-1-1

**Specification Coverage:** tns1:Configuration/Door/Changed (ONVIF Door Control Service Specification), GetDoorInfo (ONVIF Door Control Service Specification)

**Feature Under Test:** GetDoorInfo

**WSDL Reference:** event.wsdl, doorcontrol.wsdl

**Test Purpose:** To verify tns1:Configuration/Door/Changed event generation after adding new door or changing door configuration to the DUT and to verify tns1:Configuration/Door/Changed event format.

**Pre-Requisite:** Event Service was received from the DUT. Door Control Service was received from the DUT. At least one Door could be added to the DUT or changed.

**Test Configuration:** ONVIF Client and DUT

**Test Procedure:**

1. Start an ONVIF Client.
2. Start the DUT.
3. ONVIF Client will invoke **GetEventProperties** request to retrieve all events supported by the DUT.
4. Verify the **GetEventPropertiesResponse** message from the DUT.
5. Check if there is an event with Topic tns1:Configuration/Door/Changed. If there is no event with such Topic fail the test and skip other steps.
6. Check that this event isn't a Property event (MessageDescription.IsProperty = "false").
7. Check that this event contains Source.SimpleItemDescription item with Name = "DoorToken" and Type = "pt:ReferenceToken".
8. ONVIF Client will invoke **CreatePullPointSubscription** request with tns1:Configuration/Door/Changed Topic as Filter and an InitialTerminationTime of timeout1.
9. Verify that the DUT sends a **CreatePullPointSubscriptionResponse** message.
10. Test Operator will add Door or change Door configuration.
11. ONVIF Client will invoke **PullMessages** command with a PullMessagesTimeout of 20s and a MessageLimit of 1.
12. Verify that the DUT sends a **PullMessagesResponse** that contains one NotificationMessages. Repeat step 11 until Notification received.
13. Verify received Notify messages (correct value for UTC time, TopicExpression and wsnt:Message).
14. Verify that TopicExpression is equal to tns1:Configuration/Door/Changed for received message.
15. Verify that notification contains Source.SimpleItem item with Name = "DoorToken" and Value with type is equal to tdc:ReferenceToken.
16. ONVIF Client will invoke **GetDoorInfo** request (Token from Notify message) to retrieve a subset of Door Information from the DUT.



17. Verify the **GetDoorInfoResponse** message from the DUT. Verify that requested Door was returned.

**Test Result:**

**PASS –**

- DUT passes all assertions.

**FAIL –**

- The DUT did not send a **GetEventPropertiesResponse**
- The DUT did not send **CreatePullPointSubscriptionResponse** message.
- The DUT did not send **PullMessagesResponse** message.
- The DUT did not send valid SubscriptionReference.
- The DUT did not send a **GetDoorInfoResponse** with specified Door.
- The DUT did not send a Notification message that contains an event tns1:Configuration/Door/Changed with valid DoorToken.
- The DUT sent an invalid Notification message (invalid DoorToken value).
- The DUT did not return at least one Door at step 3.

**Note:** The Subscription Manager has to be deleted at the end of the test either by calling unsubscribe or through a timeout.

**Note:** ONVIF Client at step 12 will wait for Notification messages until expected notification is received or Operation Delay after last notification has expired.

**Note:** The Subscription Manager has to be deleted at the end of the test either by calling unsubscribe or through a timeout.

**Note:** The Renew has to be used for renew subscription during test, if InitialTerminationTime expires.

**Note:** If DUT cannot accept the set value to Timeout or MessageLimit, ONVIF Client retries to send the PullMessage message with Timeout and MessageLimit which is contained in PullMessagesFaultResponse.

**Note:** If DUT cannot accept the set value to a TerminationTime, ONVIF Client retries to send the Renew request MinimumTime value which is contained in UnacceptableTerminationTimeFault.

**Note:** timeout1 will be taken from Subscription Timeout field of ONVIF Device Test Tool.

## 4.6.2 DOOR CONTROL – REMOVE DOOR EVENT

**Test Case ID:** DOORCONTROL-7-1-2

**Specification Coverage:** tns1:Configuration/Door/Removed (ONVIF Door Control Service Specification), GetDoorInfo (ONVIF Door Control Service Specification)

**Feature Under Test:** GetDoorInfo

**WSDL Reference:** event.wsdl, doorcontrol.wsdl

**Test Purpose:** To verify tns1: Configuration/Door/Removed event generation after removing door from the DUT and to verify tns1: Configuration/Door/Removed event format.

**Pre-Requirement:** Event Service was received from the DUT. Door Control Service was received from the DUT. At least one Door could be removed from the DUT.

**Test Configuration:** ONVIF Client and DUT

**Test Procedure:**

1. Start an ONVIF Client.
2. Start the DUT.
3. ONVIF Client will invoke **GetEventProperties** request to retrieve all events supported by the DUT.
4. Verify the **GetEventPropertiesResponse** message from the DUT.
5. Check if there is an event with Topic tns1:Configuration/Door/Removed. If there is no event with such Topic fail the test and skip other steps.
6. Check that this event isn't a Property event (MessageDescription.IsProperty = "false").
7. Check that this event contains Source.SimpleItemDescription item with Name = "DoorToken" and Type = "pt:ReferenceToken".
8. ONVIF Client will invoke **CreatePullPointSubscription** request with tns1:Configuration/Door/Removed Topic as Filter and an InitialTerminationTime of timeout1.
9. Verify that the DUT sends a **CreatePullPointSubscriptionResponse** message.
10. Test Operator will remove Door.
11. ONVIF Client will invoke **PullMessages** command with a PullMessagesTimeout of 20s and a MessageLimit of 1.

12. Verify that the DUT sends a **PullMessagesResponse** that contains one NotificationMessages. Repeat step 11 until Notification received.
13. Verify received Notify messages (correct value for UTC time, TopicExpression and wsnt:Message).
14. Verify that TopicExpression is equal to tns1:Configuration/Door/Removed for received message.
15. Verify that notification contains Source.SimpleItem item with Name = "DoorToken" and Value with type is equal to tdc:ReferenceToken.
16. ONVIF Client will invoke **GetDoorInfo** request (Token from Notify message) to retrieve subset of Door Information from the DUT.
17. Verify the **GetDoorInfoResponse** message from the DUT. Check that empty list was returned.

**Test Result:****PASS –**

- DUT passes all assertions.

**FAIL –**

- The DUT did not send a **GetEventPropertiesResponse**
- The DUT did not send **CreatePullPointSubscriptionResponse** message.
- The DUT did not send **PullMessagesResponse** message.
- The DUT did not send valid SubscriptionReference.
- The DUT did not send a **GetDoorInfoResponse** with empty list.
- The DUT did not send a Notification message that contains an event tns1:Configuration/Door/Removed with valid DoorToken.
- The DUT sent an invalid Notification message (invalid DoorToken value).
- The DUT did not return at least one Door at step 3.

**Note:** The Subscription Manager has to be deleted at the end of the test either by calling unsubscribe or through a timeout.

**Note:** ONVIF Client at step 12 will wait for Notification messages until expected notification is received or Operation Delay after last notification has expired.

**Note:** The Subscription Manager has to be deleted at the end of the test either by calling unsubscribe or through a timeout.

**Note:** The Renew has to be used for renew subscription during test, if InitialTerminationTime expires.

**Note:** If DUT cannot accept the set value to Timeout or MessageLimit, ONVIF Client retries to send the PullMessage message with Timeout and MessageLimit which is contained in PullMessagesFaultResponse.

**Note:** If DUT cannot accept the set value to a TerminationTime, ONVIF Client retries to send the Renew request MinimumTime value which is contained in UnacceptableTerminationTimeFault.

**Note:** timeout1 will be taken from Subscription Timeout field of ONVIF Device Test Tool.

## Annex A Helper Procedures and Additional Notes

### A.1 Get Complete Door Info List

The following algorithm will be used to get a complete list of Doors:

1. ONVIF Client will invoke **GetDoorInfoList** request (no Limit, no StartReference) to retrieve the first part of Door Information list from the DUT.
2. Verify the **GetDoorInfoListResponse** message from the DUT.
3. If **GetDoorInfoListResponse** message contains NextStartReference, repeat steps 1-2 with StartReference = [current NextStartReference]. Otherwise, skip other steps and finalize getting complete door list.

The complete ordered list of doors with information will be made by the means of uniting all **GetDoorInfoListResponse** messages. Also, the total number of doors will be calculated.

### A.2 Get Complete Access Point Info List

The following algorithm will be used to get the complete list of Access Points:

1. ONVIF Client will invoke **GetAccessPointInfoList** request (no Limit, no StartReference) to retrieve the first part of Access Point Information list from the DUT.
2. Verify the **GetAccessPointInfoListResponse** message from the DUT.
3. If **GetAccessPointInfoListResponse** message contains NextStartReference, repeat steps 1-2 with StartReference = [current NextStartReference]. Otherwise, skip other steps and finalize getting complete access point list.

The complete ordered list of access points with information will be made by the means of uniting all **GetAccessPointInfoListResponse** messages. Also total number of access points will be calculated.

### A.3 Catching of Initialized event

According to ONVIF-Core-Specification (9.4 Properties Item) device shall provide notifications informing the client of all objects with the requested property, which are alive at the time of the subscription. Therefore, after **CreatePullPointSubscription** request in [DOORCONTROL-3-1-28](#) – [DOORCONTROL-3-1-36](#) tests device shall generate Initialized events with current Door State for all existing doors.

ONVIF Client will follow the following logic to catch Initialized event for required Door token:

1. ONVIF Client will invoke **PullMessages** command with a PullMessagesTimeout of 20s and a MessageLimit of 1.
2. Verify that the DUT sends a **PullMessagesResponse** that contains NotificationMessages. If no NotificationMessage for selected Door is received and Operation Delay time does not expire, ONVIF Client repeats step 1.
3. Verify that the DUT sends Notification message for selected Door with current state (Notifications for other Doors will be ignored for this test case).
4. Verify received Notification message (correct value for UTC time, TopicExpression and wsnt:Message).
5. Verify that PropertyOperation = "Initialized".
6. Verify that TopicExpression is equal to tns1:Door/State/DoorMode.
7. Verify that notification contains Source.SimpleItem item with Name = "DoorToken" and Value is equal to selected Door Token.
8. Verify that notification contains Data.SimpleItem item with Name = «State» and Value with type is equal to tdc:DoorMode.

#### FAIL –

- The DUT did not send a valid Notification message that contains a property event tns1:Door/State/DoorMode for selected Door during Operation delay time (correct value for UTC time, TopicExpression and wsnt:Message, PropertyOperation = "Initialized", Topic = "tns1:Door/State/DoorMode", contains Source.SimpleItem item with Name = "DoorToken" and Value is equal to selected Door Token, contains Data.SimpleItem item with Name = «State» and Value with type equal to tdc:DoorMode).

**Note:** Notifications for other Doors than selected will be ignored.

**Note:** Test will be failed, if no required Notification messages are received at step 3 during a certain period of time (Operation Delay should be used in ONVIF Device Test Tool).

## A.4 User Interaction Process

1. ONVIF Client sends **Unsubscribe** request to end current subscription if subscription manager has been created during test.
2. Verify **UnsubscribeResponse** message.

3. User Interaction window appears.
4. Test Operator puts Door into the appropriate state. At that state the command (used in the test), which changes the door state, shall be accepted by the DUT.
5. Returns to the test and use DoorToken from user Interaction window as token of selected Door.

## A.5 Door's transition to Locked state

ONVIF Client will try to move the selected for the test door into 'Locked' state according to the following logics:

1. ONVIF Client will invoke **GetDoorState** request (Token = "Token1", where Token1 is selected door) to retrieve current state of the door.
2. Verify **GetDoorStateResponse** from the DUT.
3. If DoorState.DoorMode is equal to Locked then skip other steps and returns to the test.
4. ONVIF Client will invoke **CreatePullPointSubscription** request with tns1:Door/State/DoorMode Topic as Filter and an InitialTerminationTime of timeout1.
5. Verify **CreatePullPointSubscriptionResponse** message from the DUT.
6. If DoorState.DoorMode is equal to Unlocked then ONVIF Client will invoke **LockDoor** request (Token = "Token1") to switch the door into Locked state. Otherwise, go to step 12.
7. Verify **LockDoorResponse** message from the DUT.
8. ONVIF Client will invoke **PullMessages** command with a PullMessagesTimeout of 20s and a MessageLimit of 1.
9. Verify that the DUT sends a **PullMessagesResponse** request. Repeat step 8 until timeout expires (Operation Delay option from ONVIF Device Test Tool will be used).
10. Check that the last Notification message with PropertyOperation = "Changed" contains Source.SimpleItem item with Name = "DoorToken" and Value is equal to Token1 and contains Data.SimpleItem item with Name = «State» and Value equal to "Locked".
11. ONVIF Client deletes Subscription Manager either by calling **Unsubscribe** or through a timeout and returns to the test.
12. If DoorState.DoorMode is equal to Accessed then ONVIF Client will invoke LockDoor request (Token = "Token1") to switch the door into Locked state. Otherwise, go to step 18.

13. Verify **LockDoorResponse** message from the DUT.
14. ONVIF Client will invoke **PullMessages** command with a PullMessagesTimeout of 20s and a MessageLimit of 1.
15. Verify that the DUT sends a **PullMessagesResponse**. Repeat step 14 until timeout expires (Operation Delay option from ONVIF Device Test Tool will be used).
16. Check that the last Notification message with PropertyOperation = "Changed" contains Source.SimpleItem item with Name = "DoorToken" and Value is equal to Token1 and contains Data.SimpleItem item with Name = «State» and Value equal to "Locked".
17. ONVIF Client deletes Subscription Manager either by calling **unsubscribe** or through a timeout and returns to the test.
18. If DoorState.DoorMode is equal to LockedDown then ONVIF Client will invoke **LockDownReleaseDoor** request (Token = "Token1") to switch the door into Locked state. Otherwise, go to step 24.
19. Verify **LockDownReleaseDoorResponse** message from the DUT.
20. ONVIF Client will invoke **PullMessages** command with a PullMessagesTimeout of 20s and a MessageLimit of 1.
21. Verify that the DUT sends a **PullMessagesResponse**. Repeat step 20 until timeout expires (Operation Delay option from ONVIF Device Test Tool will be used).
22. Check that the last Notification message with PropertyOperation = "Changed" contains Source.SimpleItem item with Name = "DoorToken" and Value is equal to Token1 and contains Data.SimpleItem item with Name = «State» and Value equal to "Locked".
23. ONVIF Client deletes Subscription Manager either by calling **unsubscribe** or through a timeout and returns to the test.
24. If DoorState.DoorMode is equal to LockedOpen then ONVIF Client will invoke **LockOpenReleaseDoor** request (Token = "Token1") to move the door into Unlocked state. Otherwise go to step 35.
25. Verify **LockOpenReleaseDoorResponse** message from the DUT.
26. ONVIF Client will invoke **PullMessages** command with a PullMessagesTimeout of 20s and a MessageLimit of 1.
27. Verify that the DUT sends a **PullMessagesResponse**. Repeat step 26 until timeout expires (Operation Delay option from ONVIF Device Test Tool will be used).



28. Check that the last Notification message with PropertyOperation = "Changed" contains Source.SimpleItem item with Name = "DoorToken" and Value is equal to Token1 and contains Data.SimpleItem item with Name = «State» and Value equal to "Unlocked".
29. ONVIF Client will invoke **LockDoor** request (Token = "Token1") to switch the door into Locked state.
30. Verify **LockDoorResponse** message from the DUT.
31. ONVIF Client will invoke **PullMessages** command with a PullMessagesTimeout of 20s and a MessageLimit of 1.
32. Verify that the DUT sends a **PullMessagesResponse**. Repeat step 31 until timeout expires (Operation Delay option from ONVIF Device Test Tool will be used).
33. Check that the last Notification message with PropertyOperation = "Changed" contains Source.SimpleItem item with Name = "DoorToken" and Value is equal to Token1 and contains Data.SimpleItem item with Name = «State» and Value equal to "Locked".
34. ONVIF Client deletes Subscription Manager either by calling **unsubscribe** or through a timeout and returns to the test.
35. If DoorState.DoorMode is equal to DoubleLocked then ONVIF Client will invoke **LockDoor** request (Token = "Token1") to move the door into Locked state. Otherwise, go to step 41.
36. Verify **LockDoorResponse** message from the DUT.
37. ONVIF Client will invoke **PullMessages** command with a PullMessagesTimeout of 20s and a MessageLimit of 1.
38. Verify that the DUT sends a **PullMessagesResponse**. Repeat step 37 until timeout expires (Operation Delay option from ONVIF Device Test Tool will be used).
39. Check that the last Notification message with PropertyOperation = "Changed" contains Source.SimpleItem item with Name = "DoorToken" and Value is equal to Token1 and contains Data.SimpleItem item with Name = «State» and Value equal to "Locked".
40. ONVIF Client deletes Subscription Manager either by calling **unsubscribe** or through a timeout and returns to the test.
41. If DoorState.DoorMode is equal to Blocked then ONVIF Client will invoke LockDoor request (Token = "Token1") to switch the door into Locked state. Otherwise, skip other steps and run user interaction process.
42. Verify **LockDoorResponse** message from the DUT.

43. ONVIF Client will invoke **PullMessages** command with a PullMessagesTimeout of 20s and a MessageLimit of 1.
44. Verify that the DUT sends a **PullMessagesResponse**. Repeat step 14 until timeout expires (Operation Delay option from ONVIF Device Test Tool will be used).
45. Check that the last Notification message with PropertyOperation = "Changed" contains Source.SimpleItem item with Name = "DoorToken" and Value is equal to Token1 and contains Data.SimpleItem item with Name = «State» and Value equal to "Locked".
46. ONVIF Client deletes Subscription Manager either by calling **unsubscribe** or through a timeout and returns to the test.

**FAIL –**

- The DUT did not send **CreatePullPointSubscriptionResponse** message.
- The DUT sent the last Notification message with PropertyOperation = "Changed" with State value not equal to expected state at step 9 or 15 or 32 or 38.
- The DUT sent an invalid Notification messages with PropertyOperation = "Changed" (correct value for UTC time, TopicExpression and wsnt:Message, Topic = "tns1:Door/State/DoorMode", contains Source.SimpleItem item with Name = "DoorToken" and Value equal to selected Door Token, contains Data.SimpleItem item with Name = «State» and Value with type equal to tdc:DoorMode).

**Note:** If the DUT sends SOAP fault to request to change door mode, then the ONVIF Client starts user interaction process (see [Annex A.4](#)).

**Note:** If DUT sends the last notification message with PropertyOperation = "Changed" with door state different from expected at step 21 or at step 27, then the ONVIF Client returns to the test and starts user interaction process (see [Annex A.4](#))